

1 Watt SLC Series

Dual Output



Features

- Low Cost
- Operating Range of 4.5 to 5.5 Volts
- Semi-Regulated 1 Watt Outputs
 - ± 5 , 12, 15 and 7, 14, 17 Volt Outputs
- Simple Five Terminal Operation
- Small SLC Package, Fits in 0.19 sq.in. of PCB Area
- Low Noise Operation
- 750 VDC Isolation Voltage
- 5 Year Warranty

Description

The CALEX SLC Dual is specifically designed to provide bipolar output voltages and isolation for 5 volt digital systems. The series provides semi-regulated outputs of 5, 12 and 15 volts for directly driving your circuits or 7, 14 and 17 volt outputs for driving three terminal regulators.

The high efficiency operation of typically 74% for a 12 volt output means efficient use of your system power.

Easy five terminal operation makes using the converter a snap. Just plug it in and you are ready to solve those nasty analog problems that arise when only 5 volt digital power is available in your system.

Selection Chart					
Model	Input Range VDC		Output		
	Min	Max	VDC	mA	Power W
5D5.075SLC	4.5	5.5	± 5.0	± 75	$\frac{3}{4}$
5D7.070SLC	4.5	5.5	± 7.0	± 70	1
5D12.040SLC	4.5	5.5	± 12.0	± 40	1
5D14.035SLC	4.5	5.5	± 14.0	± 35	1
5D15.033SLC	4.5	5.5	± 15.0	± 33	1
5D17.030SLC	4.5	5.5	± 17.0	± 30	1

1 Watt SLC Dual Series Block Diagram

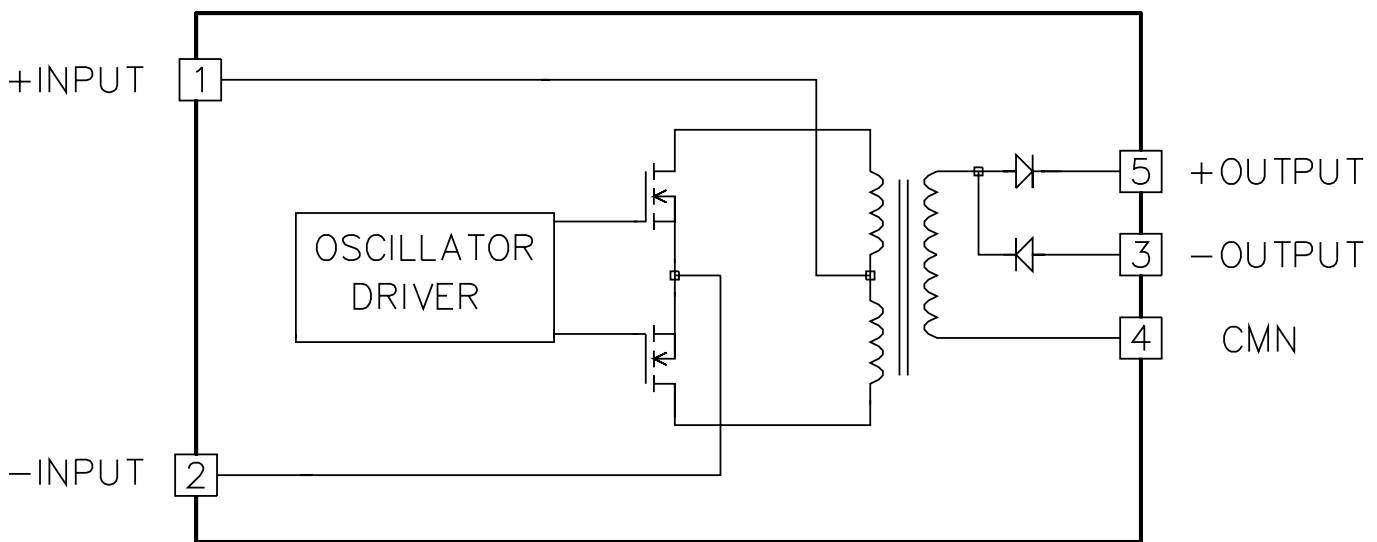

Input Parameters*								
Model		5D5.075SLC	5D7.070SLC	5D12.040SLC	5D14.035SLC	5D15.033SLC	5D17.030SLC	Units
Voltage Range	MIN	4.50						VDC
	TYP	5.00						
	MAX	5.50						
Reflected Ripple (1)	TYP	65						mA P-P
Input Current								
	Full Load	TYP	220	280	250	270	275	280
No Load	TYP	20	20	20	30	35	40	
Efficiency	TYP	69	70	73	73	74	74	%
Switching Frequency	TYP	165						kHz
Maximum Input Overvoltage 100 mSec max	MAX	6.5						VDC

Output Parameters*								
Model		5D5.075SLC	5D7.070SLC	5D12.040SLC	5D14.035SLC	5D15.033SLC	5D17.030SLC	Units
Output Voltage		±5	±7	±12	±14	±15	±17	VDC
Output Voltage Accuracy (2)	MIN	4.75	6.65	11.40	13.30	14.25	16.15	VDC
	TYP	5.00	7.00	12.00	14.00	15.00	17.00	
	MAX	5.25	7.35	12.60	14.70	15.75	17.85	
Output Balance (3)	TYP	< 1.0						%
Rated Load Range	MIN	0	0	0	0	0	0	mA
	MAX	±75	±70	±40	±35	±33	±30	
Load Regulation (4)								%
	20% - 75% Full Load	TYP	9.0					
75% - 100% Full Load	TYP	4.0						
Cross Regulation (5)	TYP	1.0					1.5	%
Line Regulation (6)	TYP	1.3						% / %
Noise, 0 to 20MHz (1)	TYP	60			40		30	mV P-P
Temperature Coefficient	TYP	400						ppm/°C
Short Circuit Protection to Common	TYP	(7)						

NOTES

* All parameters measured at Tc=25 °C case temperature, nominal input voltage and full rated load unless otherwise noted. Refer to the CALEX Applicatio Notes for definition of terms, measurement circuits and other information.

- Noise is measured per CALEX Applications notes. All noise measurements are made with a 10uF/35V Tantalum capacitor connected directly across the input and outputs. Measurement bandwidth is 0-20 MHz.
- Output voltage accuracy is measured at 75% of maximum load.
- Output balance is the percent difference in voltage from the plus to the minus output at 75% of maximum load.

- Load regulation is measured relative to 75% maximum load. Load regulation is specified with both outputs changing simultaneously.
- Cross regulation is measured relative to 75% maximum load. Cross regulation is measured by operating the +output at 75% of maximum load and varying the -output as specified. The change in the +output is the cross regulation.
- Line regulation is for a 1% change in the input voltage.
- Current limiting must be accomplished by using a current limited source or fuse in the input circuit.
- The case thermal impedance is specified as the case temperature rise over ambient per package watt dissipated.
- Specifications subject to change without notice.

General Information

The 1 Watt SLC series provides isolated, semi-regulated outputs of ±5, 7, 12, 14, 15, and 17 VDC. The high efficiency low noise push-pull design operates at 165 kHz which reduces to a minimum your external filter requirements. The converter is packaged in a non-conductive plastic case and can be water washed after being assembled to your PC board.

Applying The Input

Figure 1 shows the recommended input connections for the SLC Dual series. C1 may not be required when the power source is less than 2" from the unit. The source impedance should be less than 0.5 ohm over the frequency range of DC to 165 kHz. A 10µF/10V solid Tantalum capacitor will satisfy the requirements for C1, and should be placed as close to the converter as possible.

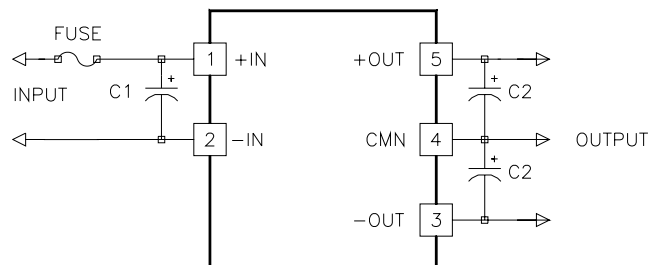

- C1 = 10µF if converter is more than 2" from the main power source.
C2 = 2.2µF minimum, 10 µF typical, may be spread around your board.

Figure 1.

Typical input and output connections for the SLC Dual series.

1 Watt SLC Series Specifications

Dual Output

General Specifications*			
All Models			Units
Isolation			
Isolation Voltage	MIN	750	VDC
Input to Output 10µA Leakage			
Input to Output Capacitance	TYP	30	pF
Environmental			
Case Operating Range	MIN	-40	°C
No Derating	MAX	85	
Storage Range	MIN	-40	°C
	MAX	100	
Thermal Impedance (8)	TYP	58	°C/Watt
Unit Weight	TYP	0.1	oz
Case Material	Non Conductive Plastic		

Output Short Circuit Protection

This series is only protected for momentary output short circuits to common so a fast acting fuse or input current limiting is recommended to protect the converter. If output shorts are possible then the protection circuit should not be omitted as it serves to prevent unlimited current from flowing in the case of an overcurrent at the load.

Very Low Noise Input Circuit

Figure 2 shows a very low noise input circuit that may be used with the converters. This circuit will reduce the input reflected ripple current to less than 10 mA peak to peak. L1 should be sized to handle the maximum DC current of your application. C1 must be used if L1 is required in the circuit.

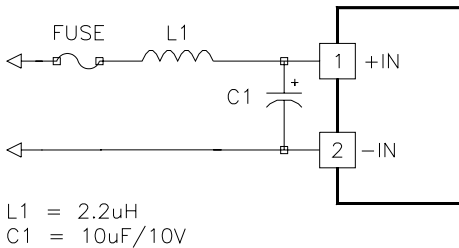

Figure 2.

This circuit will reduce the input reflected ripple current to less than 10 mA peak to peak. See the discussion in the text for selecting C1 and L1.

Applying The Output

Figure 1 shows the typical output connection for the converter. C2 is required for proper operation of the outputs. C2 should be at least 2.2µF minimum and can be made up of the bypass capacitors already used in your application. A low ESR 10µF Tantalum capacitor is recommended. Decreasing the ESR of C2 will lower the output noise.

Operation With Light Loads

This converter uses a semi-regulated design. The output voltage will vary as the load is changed, increasing as the load is decreased. See the Output Voltage vs. Output Load curve for more information.

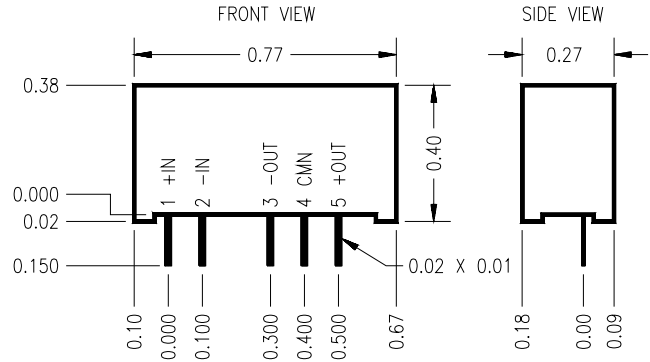

Mechanical tolerances unless otherwise noted:

X.XX dimensions: ±0.020 inches

X.XXX dimensions: ±0.010 inches

Pin	Function
1	+INPUT
2	-INPUT
3	-OUTPUT
4	CMN
5	+OUTPUT

Operation With Changing Input Voltage

The output will change proportionally to a change in the input voltage. The typical output voltage change is 1.3% per % change in input voltage.

Low Noise Output Circuit

The circuit shown in Figure 3 can be used to reduce the output noise to below 8 mV p-p over a 20 MHz bandwidth. Size inductor L2 appropriately for the maximum expected load current. All the ground connections must be as short as possible back to the CMN pin. The filter should be placed as close as possible to the converter, even if your load is at some distance.

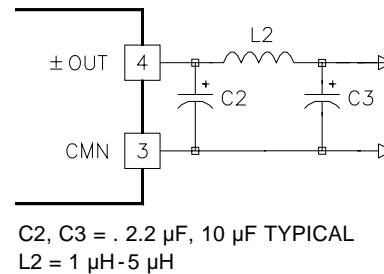

Figure 3.

This circuit can reduce the output noise to below 8mV P-P over a 20 MHz bandwidth. Size L2 for the maximum expected load current. Place as close as possible to the converter.

Single Ended Loads

The SLC Dual series may be operated in a single ended mode to get 10, 14, 24, 28, 30 or 34 volt outputs. The circuit of Figure 4 should be used for single ended operation. The CMN pin should be left floating from your application ground.

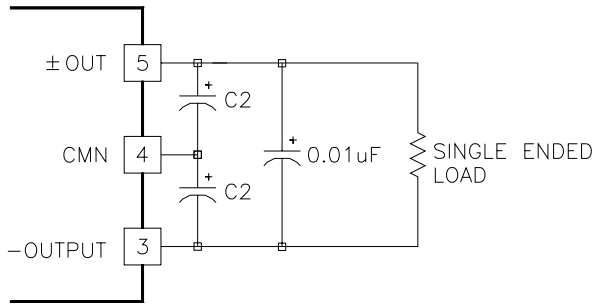

Figure 4. Unipolar output voltages up to 34 volts may be generated by operating the SLC Dual Series converters in a single ended mode. The CMN pin should not be directly used in your application.

Grounding

The input and output sections are fully floating and isolated from each other. They may be operated fully floating or with a common connection between the input and output.

Temperature Derating

The 1 Watt Output SLC series can be operated up to a +85°C case temperature. Case temperature can be roughly

calculated from ambient by knowing that the case temperature rise is approximately 58°C per package watt dissipated.

For example: If a 5D12.040SLC is delivering 0.9 watts at 5V input, at what ambient could it expect to run with no additional cooling such as moving air?

Efficiency is approximately 73% which leads to an input power of 1.23 watts. The internal power loss is $1.23 - .9 = 0.33$ watts. The case temperature rise will be $0.33W \times 58^\circ C/W = 19.1^\circ C$. This number is subtracted from the maximum case temperature rating of 85°C to get 65.9°C, which is the maximum ambient operating temperature.

This example calculation is for an application with no extra air flow for cooling. Extra cooling air will greatly effect the maximum ambient temperature. Exact internal power loss depends upon the efficiency, input voltage, and load in the application.

The above example is a rough approximation to the maximum ambient temperature. Because of the difficulty of defining ambient temperature, these calculations should be verified by actual measurement before committing to a production design.

Typical Performance: (Tc=25°C)

