



**UF60-005
THRU
UF60-10**

6A ULTRA FAST RECOVERY RECTIFIER

FEATURES

- PLASTIC PACKAGE HAS UNDERWRITERS LABORATORY FLAMMABILITY CLASSIFICATION 94V-0
- ULTRA FAST RECOVERY TIMES FOR HIGH EFFICIENCY
- LOW FORWARD VOLTAGE, HIGH CURRENT CAPABILITY
- LOW LEAKAGE
- HIGH SURGE CAPABILITY
- HIGH TEMPERATURE SOLDERING GUARANTEED:
260°C .375" (9.5mm) LEAD LENGTHS FOR 10 SECONDS AT 5 LBS. (2.3 KG) TENSION.

MECHANICAL DATA

- CASE : JEDEC DO-201AD, MOLDED PLASTIC
- TERMINALS : AXIAL LEADS SOLDERABLE PER MIL-STD-202, METHOD 208
- POLARITY : COLOR BAND DENOTES CATHODE END
- MOUNTING POSITION : ANY
- WEIGHT : 2.1 GRAM

CASE-P6

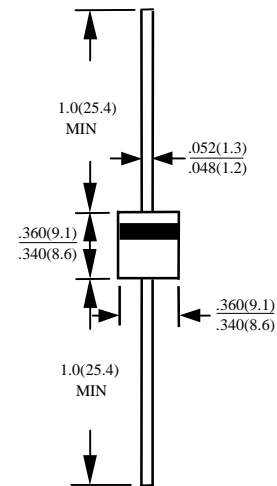

DIMENSIONS IN INCHES AND (MILLIMETERS)

MAXIMUM RATINGS AND ELECTRICAL CHARACTERISTICS

RATINGS AT 25°C AMBIENT TEMPERATURE UNLESS OTHERWISE SPECIFIED
SINGLE PHASE, HALF WAVE, 60 HZ, RESISTIVE OR INDUCTIVE LOAD.
FOR CAPACITIVE LOAD, DERATE CURRENT BY 20%

RATINGS	SYMBOL	UF60-005	UF60-01	UF60-02	UF60-04	UF60-06	UF60-08	UF60-10	UNITS
MAXIMUM RECURRENT PEAK REVERSE VOLTAGE	V_{RRM}	50	100	200	400	600	800	1000	V
MAXIMUM RMS VOLTAGE	V_{RMS}	35	70	140	280	420	560	700	V
MAXIMUM DC BLOCKING VOLTAGE	V_{DC}	50	100	200	400	600	800	1000	V
MAXIMUM AVERAGE FORWARD RECTIFIED CURRENT .375" (9.5mm) LEAD LENGTH AT TA=50°C	I_o	6.0							A
PEAK FORWARD SURGE CURRENT 8.3ms SINGLE HALF SINE-WAVE SUPERIMPOSED ON RATED LOAD	I_{FSM}	300							A
TYPICAL JUNCTION CAPACITANCE (NOTE 1)	C_j	150							PF
TYPICAL THERMAL RESISTANCE (NOTE 2)	$R_{\theta ja}$	10							°C/W
STORAGE TEMPERATURE RANGE	T_{STG}	-55 TO + 150							°C
OPERATING TEMPERATURE RANGE	T_{OP}	-55 TO + 150							°C

ELECTRICAL CHARACTERISTICS (AT TA =25°C UNLESS OTHERWISE NOTED)

CHARACTERISTICS	SYMBOL	UF60-005	UF60-01	UF60-02	UF60-04	UF60-06	UF60-08	UF60-10	UNITS	
MAXIMUM FORWARD VOLTAGE AT 3.0A	V_F	1.0			1.4	1.7	2.0		V	
MAXIMUM REVERSE CURRENT AT TA=25°	I_R	25							μA	
MAXIMUM REVERSE CURRENT AT TA=100°	I_R	250							μA	
MAXIMUM REVERSE RECOVERY TIME (NOTE3)	T_{RR}	50				75				nS

NOTE :

1. MEASURED AT 1 MHZ AND APPLIED REVERSE VOLTAGE OF 4.0 VOLTS
2. BOTH LEADS ATTACHED TO HEATSINK 70x 70x 1t(mm) COPPER PLATE AT LEAD LENGTH 5mm
3. REVERSE RECOVERY TEST CONDITIONS: $I_F=0.5A, I_R=1.0A, I_{RR}=0.25A$

RATINGS AND CHARACTERISTIC CURVE UF60-005 THRU UF60-10

FIG. 1 - TEST CIRCUIT DIAGRAM AND REVERSE RECOVERY TIME CHARACTERISTIC

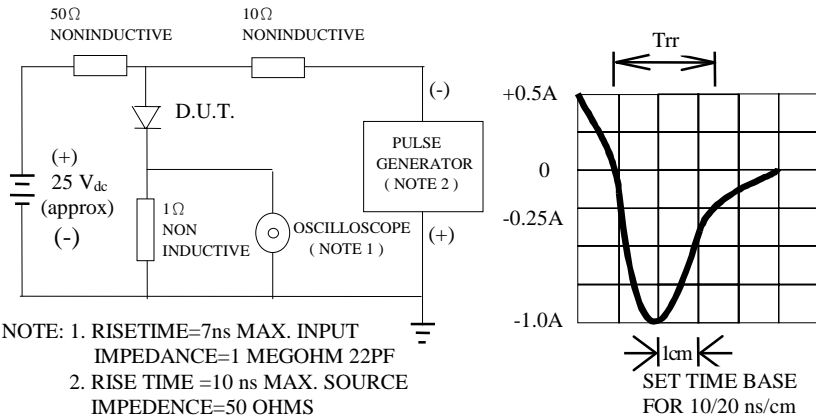

FIG. 2 - TYPICAL FORWARD CURRENT DERATING CURVE

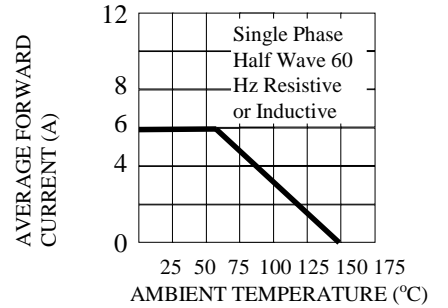

FIG. 3 - TYPICAL REVERSE CHARACTERISTICS

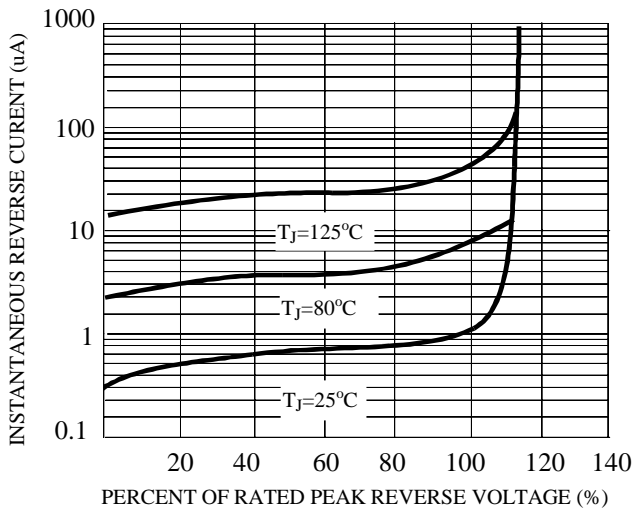

FIG. 4 - TYPICAL INSTANTANEOUS FORWARD CHARACTERISTICS

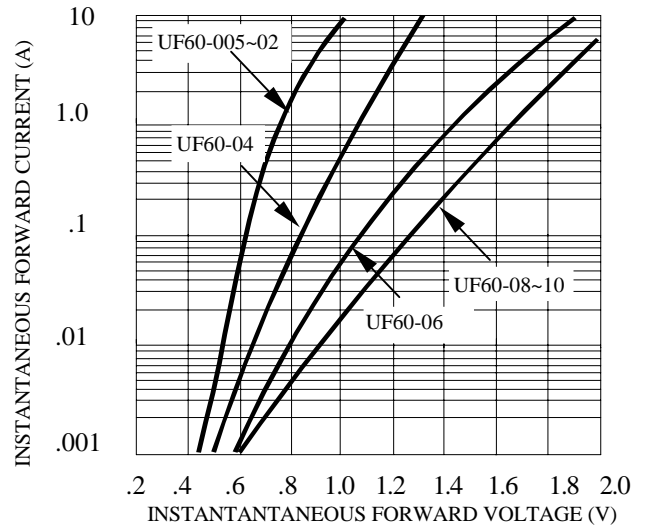

FIG. 5 - MAXIMUM NON-REPETITIVE FORWARD SURGE CURRENT

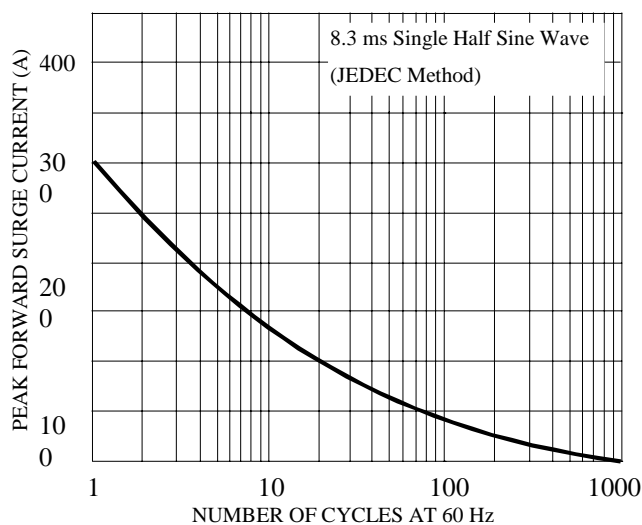

FIG. 6 - TYPICAL JUNCTION CAPACITANCE

