

PRELIMINARY DATA SHEET

NEC

C TO X BAND AMPLIFIER C TO X BAND OSC N-CHANNEL GaAs MESFET

NE72118

FEATURES

- **HIGH POWER GAIN:**
Gs = 5.5 dB TYP at f = 12 GHz
- **LOW PHASE NOISE:**
-110 dBc/Hz TYP at 100 KHz off set at f = 11 GHz
- **GATE LENGTH:** Lg = 0.8 μm (recessed gate)
- **GATE WIDTH:** Wg = 330 μm
- **4 PINS SUPER MINI MOLD (SOT-343)**
- **TAPE & REEL PACKAGING**

DESCRIPTION

The NE72118 is a high performance gallium arsenide metal semiconductor field effect transistor (MESFET), housed in a low cost plastic surface mount package (SOT 23 style). This device's low phase noise and high ft make it an excellent choice for oscillator applications on a digital LNB (Low Noise Block).

NEC's stringent quality assurance and test procedures ensure the highest reliability performance.

PACKAGE DIMENSIONS (Units in mm)

PACKAGE OUTLINE 18

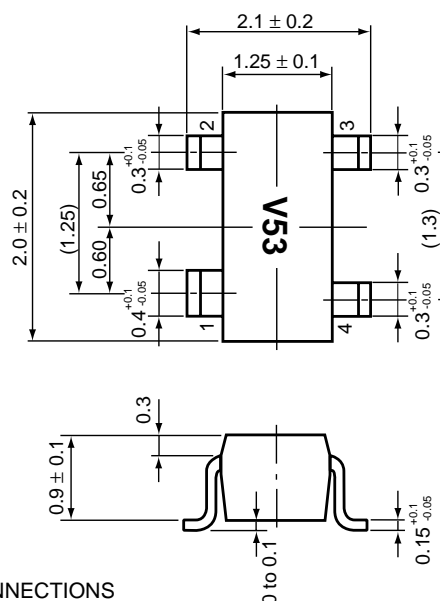

PIN CONNECTIONS

1. Source
2. Gate
3. Source
4. Drain

ELECTRICAL CHARACTERISTICS (TA = 25°C)

PART NUMBER PACKAGE OUTLINE			NE72118 18		
SYMBOLS	PARAMETERS AND CONDITIONS	UNITS	MIN	TYP	MAX
IGSO	Gate to Source Leak Current at VGS = -5 V	μA		1.0	10
IDSS	Saturated Drain Current at VDS = 3 V, VGS = 0 V	μA	30	60	100
VGS(OFF)	Gate to Source Cut off Voltage at VDS = 3 V, ID = 100 μA	V	-0.5	-2.0	-4.0
gm	Transconductance at VDS = 3 V, ID = 30 mA	mS	20	40	
PN	Phase Noise at VDS=3 V, ID=30mA, f=11GHz, 100KHz offset	dBc/Hz		-110	
	Phase Noise at VDS=3 V, ID=30mA, f=11GHz, 10KHz offset	dBc/Hz		-85	
Gs	Power Gain at VDS = 3 V, ID = 30 mA, f = 12 GHz	dB		5.5	
Po (1dB)	Output Power at 1 dB Gain Compression Point at VCE = 3 V, ID = 30 mA, f = 12 GHz	dBm		13.5	

ABSOLUTE MAXIMUM RATINGS¹ (T_A = 25°C)

SYMBOLS	PARAMETERS	UNITS	RATINGS
V _{DS}	Drain to Source Voltage	V	5.0
V _{GS}	Gate to Source Voltage	V	-6.0
V _{GD}	Gate to Drain Voltage	V	-6.0
I _D	Drain Current	mA	I _{DSS}
P _{TOT}	Total Power Dissipation	mW	250
T _{CH}	Channel Temperature	°C	125
T _{STG}	Storage Temperature	°C	-65 to +125

Notes:

1. Operation in excess of any one of these parameters may result in permanent damage.

ORDERING INFORMATION

PART NUMBER	QUANTITY
NE72118-T1	3K/Reel
NE72118-T2	3K/Reel

TYPICAL PERFORMANCE CURVES (T_A = 25°C)

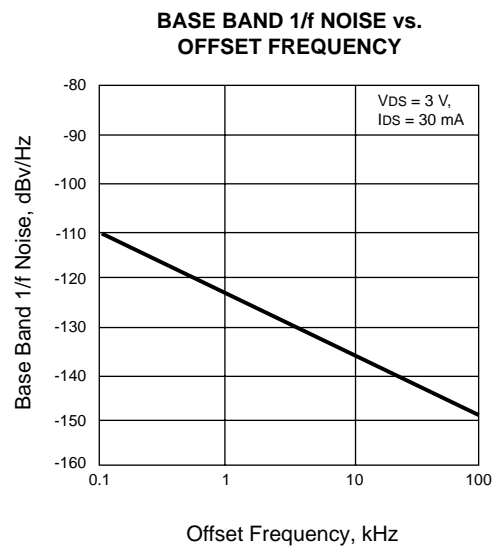
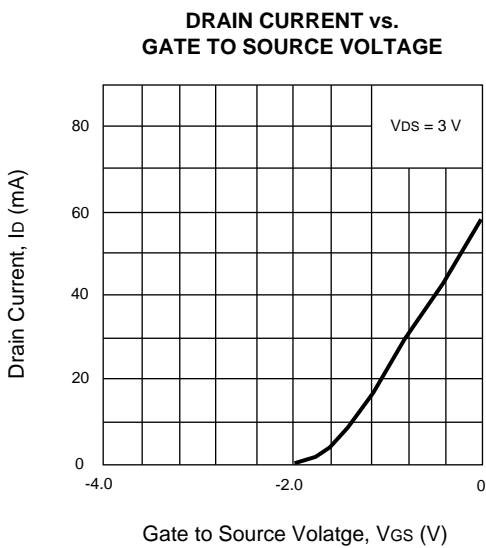
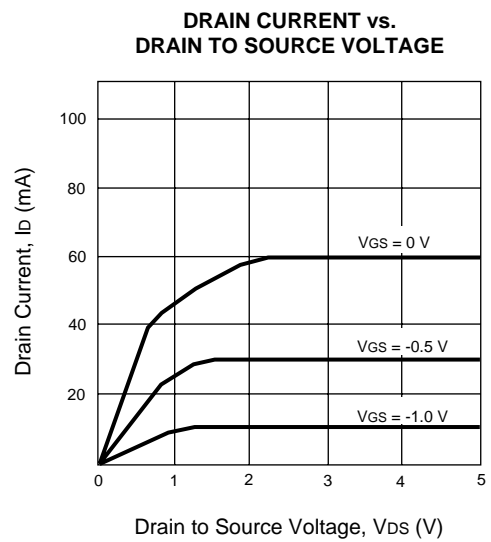
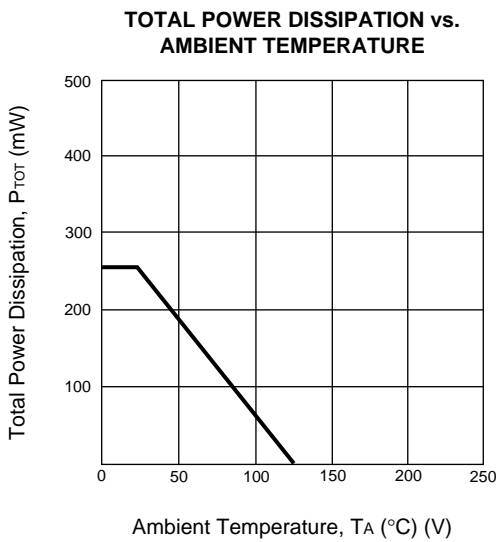

TYPICAL SCATTERING PARAMETERS (T_A = 25°C)V_{Ds} = 3 V, I_D = 10 mA

FREQUENCY (MHz)	S ₁₁		S ₂₁		S ₁₂		S ₂₂		K	MAG ¹ (dB)
	MAG	ANG	MAG	ANG	MAG	ANG	MAG	ANG		
2000	0.922	-46.8	2.257	134.5	0.067	58.5	0.667	-27.5	0.38	17.86
3000	0.864	-66.8	2.171	116.4	0.089	47.7	0.627	-39.0	0.50	14.86
4000	0.784	-89.8	2.125	97.4	0.104	37.0	0.591	-49.5	0.65	12.57
5000	0.709	-116.1	2.049	77.5	0.110	25.3	0.545	-58.9	0.83	10.79
6000	0.658	-140.5	1.927	58.5	0.107	17.8	0.481	-68.0	1.08	10.84
7000	0.623	-164.0	1.780	40.2	0.101	13.2	0.416	-80.0	1.38	8.79
8000	0.597	171.4	1.639	23.3	0.095	12.7	0.358	-92.8	1.72	7.42
9000	0.613	146.3	1.545	6.5	0.100	16.8	0.323	-109.6	1.70	7.03
10000	0.677	125.6	1.450	-12.0	0.117	16.3	0.284	-137.3	1.37	7.31
11000	0.749	107.4	1.297	-31.1	0.136	10.0	0.251	-178.5	1.13	7.58
12000	0.797	90.8	1.117	-48.8	0.147	1.6	0.295	138.4	1.07	7.19
13000	0.839	78.4	0.959	-65.1	0.159	-8.4	0.395	107.9	0.95	5.67
14000	0.877	65.7	0.811	-82.3	0.164	-20.8	0.499	85.8	0.83	5.79
15000	0.909	51.9	0.636	-99.1	0.157	-33.1	0.577	68.3	0.79	5.42
16000	0.934	43.9	0.483	-111.1	0.145	-42.7	0.643	54.4	0.75	4.97
17000	0.928	40.2	0.376	-118.6	0.136	-49.3	0.733	44.4	0.86	3.43
18000	0.920	31.7	0.306	-125.6	0.126	-55.8	0.795	39.5	0.97	2.18

V_{Ds} = 3 V, I_D = 20 mA

FREQUENCY (MHz)	S ₁₁		S ₂₁		S ₁₂		S ₂₂		K	MAG ¹ (dB)
	MAG	ANG	MAG	ANG	MAG	ANG	MAG	ANG		
2000	0.907	-49.0	2.672	133.0	0.061	58.3	0.637	-27.5	0.43	18.30
3000	0.838	-69.9	2.534	114.7	0.081	48.6	0.594	-38.8	0.56	15.23
4000	0.752	-93.4	2.437	95.8	0.093	38.1	0.561	-48.8	0.72	13.00
5000	0.675	-120.3	2.318	76.0	0.098	29.5	0.521	-57.4	0.91	11.31
6000	0.627	-144.7	2.155	57.5	0.096	24.3	0.459	-65.3	1.15	11.13
7000	0.591	-168.0	1.972	39.6	0.095	21.6	0.394	-76.3	1.43	9.29
8000	0.570	167.6	1.803	23.2	0.093	22.7	0.337	-88.8	1.72	7.97
9000	0.592	143.3	1.695	7.0	0.104	24.6	0.307	-104.8	1.58	7.66
10000	0.666	123.6	1.594	-11.0	0.125	22.4	0.269	-132.2	1.23	8.19
11000	0.742	105.8	1.429	-29.9	0.144	13.7	0.226	-173.8	1.03	8.85
12000	0.794	89.6	1.239	-47.1	0.157	4.7	0.260	139.7	0.98	6.49
13000	0.838	77.7	1.073	-63.6	0.168	-5.6	0.365	107.7	0.89	6.50
14000	0.880	65.3	0.913	-81.1	0.173	-18.0	0.476	85.9	0.77	6.78
15000	0.914	51.1	0.723	-98.1	0.166	-31.7	0.552	69.2	0.71	6.60
16000	0.939	43.3	0.552	-110.5	0.153	-40.2	0.617	55.1	0.68	6.17
17000	0.935	39.5	0.431	-118.9	0.141	-48.1	0.707	44.5	0.76	4.73
18000	0.920	30.8	0.350	-124.9	0.134	-57.2	0.788	39.6	0.86	3.20

Note:

1. Gain Calculation:

$$\text{MAG} = \frac{|S_{21}|}{|S_{12}|} \left(K \pm \sqrt{K^2 - 1} \right). \text{ When } K \leq 1, \text{ MAG is undefined and MSG values are used. } \text{MSG} = \frac{|S_{21}|}{|S_{12}|}, K = \frac{1 + |\Delta|^2 - |S_{11}|^2 - |S_{22}|^2}{2 |S_{12} S_{21}|}, \Delta = S_{11} S_{22} - S_{21} S_{12}$$

TYPICAL SCATTERING PARAMETERS (T_A = 25°C)V_{DS} = 3 V, I_D = 30 mA

FREQUENCY (MHz)	S ₁₁		S ₂₁		S ₁₂		S ₂₂		K	MAG ¹ (dB)
	MAG	ANG	MAG	ANG	MAG	ANG	MAG	ANG		
2000	0.900	-50.1	2.906	132.3	0.058	58.4	0.640	-27.1	0.44	18.76
3000	0.826	-71.2	2.733	114.0	0.074	49.0	0.596	-38.2	0.59	15.62
4000	0.734	-94.9	2.611	95.2	0.086	39.8	0.563	-47.6	0.76	13.35
5000	0.657	-121.9	2.466	75.7	0.088	32.6	0.524	-55.7	0.96	11.69
6000	0.609	-146.2	2.286	57.4	0.089	28.1	0.468	-63.2	1.19	11.46
7000	0.577	-169.5	2.084	39.8	0.089	27.6	0.407	-74.0	1.44	9.76
8000	0.558	166.5	1.899	23.7	0.091	30.1	0.354	-85.7	1.66	8.46
9000	0.581	142.6	1.789	7.8	0.104	31.9	0.323	-101.4	1.50	8.17
10000	0.659	123.3	1.688	-10.0	0.130	27.7	0.285	-127.2	1.12	9.05
11000	0.739	105.9	1.522	-28.8	0.152	18.4	0.238	-167.1	0.93	7.33
12000	0.794	89.9	1.324	-46.2	0.164	8.5	0.260	145.9	0.89	7.06
13000	0.840	77.8	1.150	-62.6	0.177	-2.9	0.359	112.2	0.80	7.14
14000	0.888	65.3	0.983	-80.4	0.183	-16.4	0.469	89.2	0.68	7.67
15000	0.923	51.2	0.781	-97.6	0.175	-29.8	0.549	71.6	0.62	7.68
16000	0.944	43.3	0.596	-110.4	0.157	-39.7	0.621	56.4	0.60	7.28
17000	0.941	39.4	0.465	-119.0	0.147	-47.1	0.712	45.5	0.67	5.80
18000	0.922	30.8	0.374	-125.9	0.136	-54.5	0.787	40.0	0.82	3.89

V_{DS} = 3 V, I_D = 40 mA

FREQUENCY (MHz)	S ₁₁		S ₂₁		S ₁₂		S ₂₂		K	MAG ¹ (dB)
	MAG	ANG	MAG	ANG	MAG	ANG	MAG	ANG		
2000	0.894	-50.6	3.050	132.1	0.053	59.6	0.660	-26.6	0.44	19.16
3000	0.817	-72.0	2.858	113.7	0.068	49.2	0.615	-37.0	0.61	15.97
4000	0.725	-95.7	2.716	95.0	0.078	41.5	0.582	-46.0	0.79	13.72
5000	0.647	-122.6	2.556	75.8	0.080	33.7	0.546	-53.7	1.00	14.83
6000	0.600	-146.6	2.368	57.7	0.079	34.1	0.495	-61.2	1.24	11.83
7000	0.569	-170.0	2.156	40.2	0.082	34.0	0.440	-71.7	1.45	10.21
8000	0.550	166.1	1.968	24.2	0.086	37.9	0.394	-82.9	1.63	8.96
9000	0.571	142.5	1.855	8.7	0.104	40.5	0.366	-97.4	1.41	8.73
10000	0.653	123.9	1.760	-9.0	0.134	35.6	0.329	-121.7	1.00	10.81
11000	0.737	106.6	1.602	-27.9	0.159	24.5	0.279	-158.0	0.82	7.85
12000	0.799	90.5	1.398	-45.5	0.176	13.2	0.282	157.2	0.76	7.69
13000	0.846	78.3	1.215	-62.3	0.188	1.8	0.368	120.6	0.71	7.79
14000	0.895	65.9	1.045	-80.3	0.195	-12.7	0.477	95.3	0.59	8.52
15000	0.931	51.6	0.827	-98.1	0.186	-26.9	0.562	75.6	0.53	8.73
16000	0.956	43.6	0.630	-111.4	0.169	-38.4	0.635	59.3	0.48	8.84
17000	0.949	39.4	0.487	-120.5	0.158	-47.0	0.724	47.5	0.53	6.97
18000	0.932	30.6	0.386	-127.2	0.144	-53.2	0.792	41.7	0.69	4.84

Note:

1. Gain Calculation:

$$\text{MAG} = \frac{|S_{21}|}{|S_{12}|} \left(K \pm \sqrt{K^2 - 1} \right). \text{ When } K \leq 1, \text{ MAG is undefined and MSG values are used. } \text{MSG} = \frac{|S_{21}|}{|S_{12}|}, K = \frac{1 + |\Delta|^2 - |S_{11}|^2 - |S_{22}|^2}{2 |S_{12} S_{21}|}, \Delta = S_{11} S_{22} - S_{21} S_{12}$$

NONLINEAR MODEL

SCHEMATIC

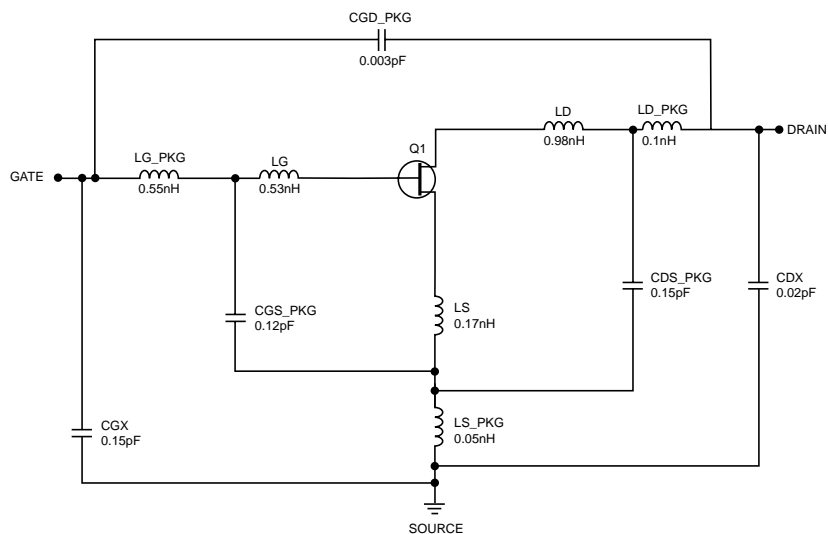

FET NONLINEAR MODEL PARAMETERS (1)

Parameters	Q1	Parameters	Q1
VTO	-1.32	RG	5
VTOSC	0	RD	4
ALPHA	2.5	RS	4
BETA	0.0281	RGMET	0
GAMMA	0.08	KF	1.36e-10
GAMMADC	0.05	AF	1.74
Q	2	TNOM	27
DELTA	1.1	XTI	3
VBI	0.6	EG	1.43
IS	1e-14	VTOTC	0
N	1	BETATCE	0
RIS	0	FFE	1
RID	0		
TAU	4e-12		
CDS	0.21e-12		
RDB	5000		
CBS	1e-10		
CGSO	0.65e-12		
CGDO	0.046e-12		
DELTA 1	0.05		
DELTA 2	0.2		
FC	0.5		
VBR	Infinity		

(1) Series IV Libra TOM Model

UNITS

Parameter	Units
time	seconds
capacitance	farads
inductance	henries
resistance	ohms
voltage	volts
current	amps

MODEL RANGE

Frequency: 0.5 to 18 GHz

Bias: $V_{DS} = 2\text{ V to }4\text{ V}$, $I_D = 10\text{ mA to }30\text{ mA}$
 $I_{DSS} = 41\text{ mA @ }V_{GS} = 0\text{ V}, V_{DS} = 3\text{ V}$ Power: $V_{DS} = 3\text{ V}$, $I_D = 30\text{ mA}$, 4 GHz

Date: 4/98

EXCLUSIVE NORTH AMERICAN AGENT FOR **NEC** RF, MICROWAVE & OPTOELECTRONIC SEMICONDUCTORS**CEL** CALIFORNIA EASTERN LABORATORIES • Headquarters • 4590 Patrick Henry Drive • Santa Clara, CA 95054-1817 • (408) 988-3500 • Telex 34-6393 • FAX (408) 988-0279
24-Hour Fax-On-Demand: 800-390-3232 (U.S. and Canada only) • Internet: <http://WWW.CEL.COM>

DATA SUBJECT TO CHANGE WITHOUT NOTICE

9/98