

PRELIMINARY DATA SHEET

NEC

C to KU BAND SUPER LOW NOISE AMPLIFIER N-CHANNEL HJ-FET

NE425S01

FEATURES

- **SUPER LOW NOISE FIGURE:**
0.60 dB TYP at 12 GHz
- **HIGH ASSOCIATED GAIN:**
12.0 dB TYP at $f = 12$ GHz
- **GATE LENGTH:** $\leq 0.20 \mu\text{m}$
- **GATE WIDTH:** $200 \mu\text{m}$
- **LOW COST PLASTIC PACKAGE**

DESCRIPTION

The NE425S01 is a Hetero-Junction FET that utilizes the hetero junction to create high mobility electrons. Its excellent low noise and high associated gain make it suitable for DBS and other commercial systems.

NEC's stringent quality assurance and test procedures assure the highest reliability and performance.

NOISE FIGURE & ASSOCIATED GAIN vs. FREQUENCY

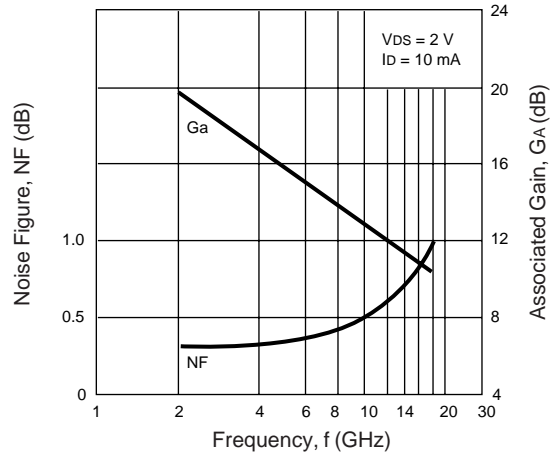

RECOMMENDED OPERATING CONDITIONS (TA = 25°C)

| SYMBOLS | CHARACTERISTICS | UNITS | MIN | TYP | MAX |
|-----------------|-------------------------|-------|-----|-----|-----|
| V _{DS} | Drain to Source Voltage | V | | 2 | 3 |
| I _D | Drain Current | mA | | 10 | 20 |
| P _{in} | Input Power | dBm | | | 0 |

ELECTRICAL CHARACTERISTICS (TA = 25°C)

| PART NUMBER PACKAGE OUTLINE | | | NE425S01 S01 | | |
|--------------------------------|---|-------|-----------------|------|------|
| SYMBOLS | PARAMETERS AND CONDITIONS | UNITS | MIN | TYP | MAX |
| I _{GSO} | Gate to Source Leak Current, V _{GS} = -3 V | μA | | 0.5 | 10 |
| I _{DSS} | Saturated Drain Current, V _{DS} = 2 V, V _{GS} = 0 V | mA | 20 | 60 | 90 |
| V _{GS(off)} | Gate to Source Cutoff Voltage, V _{DS} = 2 V, I _D = 100 μA | V | -0.2 | -0.7 | -2.0 |
| g _m | Transconductance, V _{DS} = 2 V, I _D = 10 mA | mS | 45 | 60 | |
| NF ¹ | Noise Figure, V _{DS} = 2 V, I _D = 10 mA, f = 12 GHz | dB | | 0.60 | 0.80 |
| GA ¹ | Associated Gain, V _{DS} = 2 V, I _D = 10 mA, f = 12 GHz | dB | 10.5 | 12.0 | |

Note:

1. Typical values of noise figures and associated gain are those obtained when 50% of the devices from a large number of lots were individually measured in a circuit with the input individually tuned to obtain the minimum value. Maximum values are criteria established on the production line as a "go-no-go" screening tuned for the "generic" type but not each specimen.

ABSOLUTE MAXIMUM RATINGS¹ (T_A = 25°C)

| SYMBOLS | PARAMETERS | UNITS | RATINGS |
|------------------|-------------------------|-------|------------------|
| V _{DS} | Drain to Source Voltage | V | 4.0 |
| V _{GS} | Gate to Source Voltage | V | -3.0 |
| I _D | Drain Current | mA | I _{DSS} |
| I _G | Gate Current | μA | 100 |
| P _T | Total Power Dissipation | mW | 165 |
| T _{CH} | Channel Temperature | °C | 125 |
| T _{stg} | Storage Temperature | °C | -65 to +125 |

Note:

1. Operation in excess of any one of these parameters may result in permanent damage.

NOISE FIGURE, ASSOCIATED GAIN vs. DRAIN CURRENT

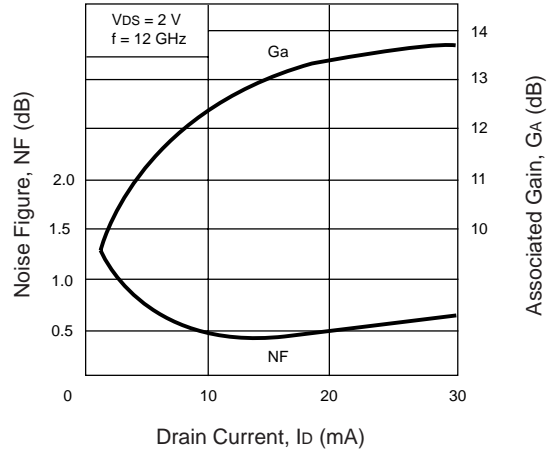

TYPICAL PERFORMANCE CURVES (T_A = 25°C)

TOTAL POWER DISSIPATION vs. AMBIENT TEMPERATURE

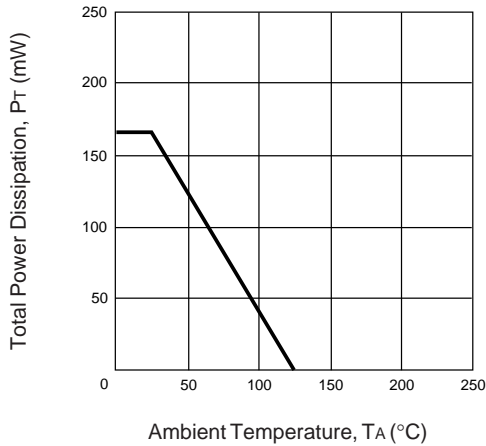

DRAIN CURRENT vs. DRAIN TO SOURCE VOLTAGE

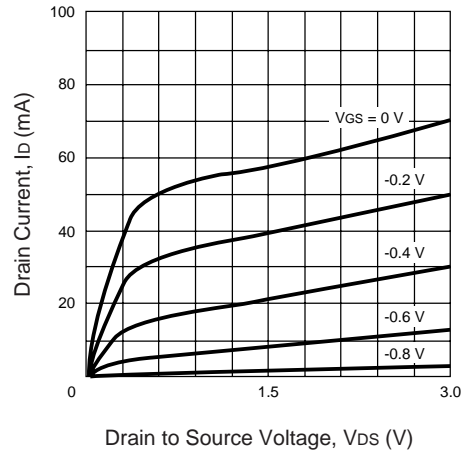

DRAIN CURRENT vs. GATE TO SOURCE VOLTAGE

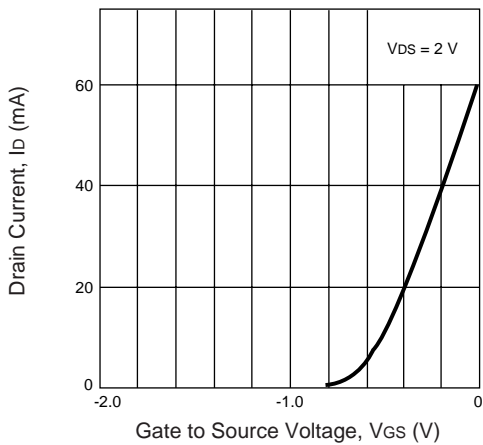

MAXIMUM AVAILABLE GAIN, FORWARD INSERTION GAIN vs. FREQUENCY

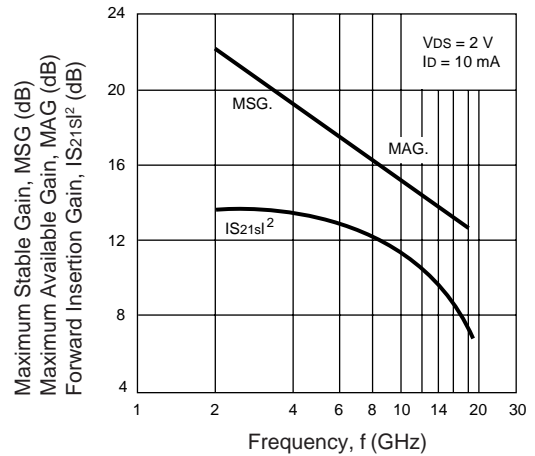

TYPICAL COMMON SOURCE SCATTERING PARAMETERS (T_A = 25°C)

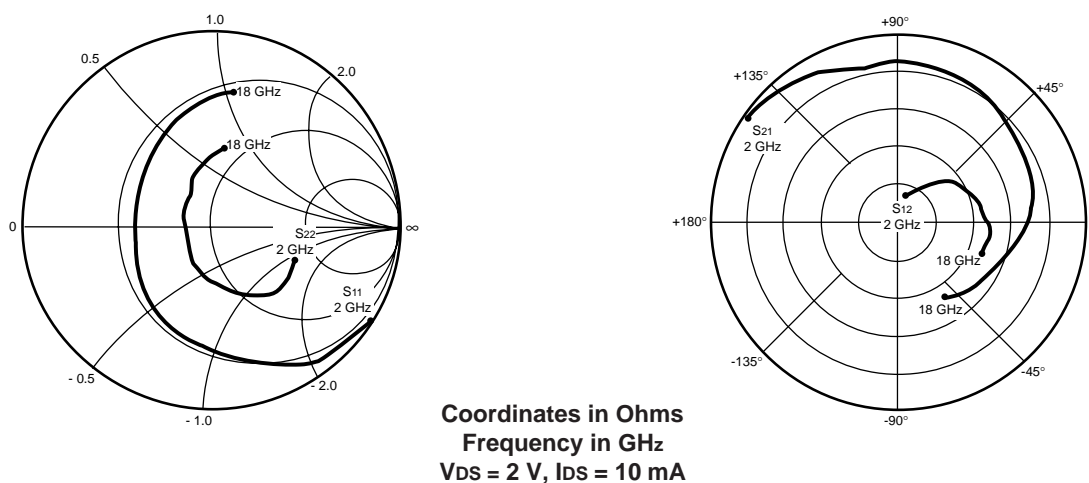

V_{DS} = 2 V, I_D = 10 mA

| FREQUENCY (GHz) | S ₁₁ | | S ₂₁ | | S ₁₂ | | S ₂₂ | | K | MAG ¹ (dB) |
|--------------------|-----------------|--------|-----------------|-------|-----------------|-------|-----------------|--------|------|--------------------------|
| | MAG | ANG | MAG | ANG | MAG | ANG | MAG | ANG | | |
| 2.0 | 0.999 | -26.7 | 4.914 | 151.5 | 0.029 | 74.5 | 0.444 | -18.9 | .02 | |
| 2.5 | 0.994 | -29.0 | 4.748 | 147.2 | 0.036 | 73.3 | 0.507 | -26.8 | .05 | 34.12 |
| 3.0 | 0.952 | -38.8 | 4.770 | 137.3 | 0.044 | 65.3 | 0.472 | -32.7 | .25 | 24.91 |
| 3.5 | 0.939 | -44.6 | 4.654 | 131.3 | 0.050 | 62.7 | 0.485 | -37.1 | .27 | 23.80 |
| 4.0 | 0.926 | -51.1 | 4.547 | 125.0 | 0.055 | 59.3 | 0.490 | -40.9 | .29 | 22.80 |
| 4.5 | 0.866 | -56.7 | 4.413 | 117.6 | 0.059 | 53.7 | 0.477 | -45.3 | .48 | 20.04 |
| 5.0 | 0.821 | -60.6 | 4.285 | 111.6 | 0.064 | 50.8 | 0.474 | -48.5 | .59 | 18.61 |
| 5.5 | 0.783 | -63.7 | 4.192 | 105.7 | 0.069 | 48.4 | 0.465 | -51.7 | .67 | 17.63 |
| 6.0 | 0.788 | -70.5 | 4.207 | 99.8 | 0.075 | 45.1 | 0.439 | -55.4 | .64 | 17.62 |
| 6.5 | 0.755 | -76.1 | 4.219 | 93.7 | 0.079 | 41.7 | 0.421 | -58.9 | .70 | 17.02 |
| 7.0 | 0.721 | -82.9 | 4.231 | 87.2 | 0.085 | 38.6 | 0.401 | -63.4 | .73 | 16.47 |
| 7.5 | 0.679 | -91.9 | 4.234 | 80.0 | 0.092 | 33.4 | 0.361 | -69.3 | .78 | 15.82 |
| 8.0 | 0.634 | -101.6 | 4.207 | 72.6 | 0.095 | 28.8 | 0.322 | -75.7 | .84 | 15.19 |
| 8.5 | 0.595 | -111.7 | 4.136 | 65.3 | 0.098 | 24.2 | 0.288 | -83.0 | .89 | 14.60 |
| 9.0 | 0.563 | -122.5 | 4.059 | 58.1 | 0.104 | 20.5 | 0.256 | -92.1 | .91 | 14.12 |
| 9.5 | 0.537 | -132.5 | 3.958 | 51.1 | 0.105 | 16.0 | 0.229 | -101.2 | .96 | 13.66 |
| 10.0 | 0.505 | -142.0 | 3.834 | 44.3 | 0.108 | 11.7 | 0.208 | -108.5 | 1.00 | 15.21 |
| 10.5 | 0.478 | -151.0 | 3.735 | 38.3 | 0.109 | 8.6 | 0.187 | -114.8 | 1.06 | 13.86 |
| 11.0 | 0.451 | -159.2 | 3.647 | 32.5 | 0.110 | 5.3 | 0.164 | -120.0 | 1.11 | 13.15 |
| 11.5 | 0.421 | -168.7 | 3.609 | 26.6 | 0.112 | 1.9 | 0.147 | -124.7 | 1.15 | 12.73 |
| 12.0 | 0.415 | 179.9 | 3.589 | 20.6 | 0.115 | 0.3 | 0.124 | -133.2 | 1.15 | 12.61 |
| 12.5 | 0.424 | 167.1 | 3.556 | 13.4 | 0.116 | -3.3 | 0.108 | -151.1 | 1.15 | 12.56 |
| 13.0 | 0.448 | 152.5 | 3.473 | 5.5 | 0.122 | -7.9 | 0.103 | 175.2 | 1.11 | 12.56 |
| 13.5 | 0.477 | 138.9 | 3.331 | -1.8 | 0.121 | -13.1 | 0.126 | 143.2 | 1.12 | 12.31 |
| 14.0 | 0.508 | 128.1 | 3.161 | -8.5 | 0.118 | -15.9 | 0.157 | 120.6 | 1.15 | 11.91 |
| 14.5 | 0.530 | 120.0 | 3.006 | -14.2 | 0.115 | -18.0 | 0.184 | 110.2 | 1.19 | 11.54 |
| 15.0 | 0.554 | 113.2 | 2.913 | -19.4 | 0.118 | -18.9 | 0.214 | 106.0 | 1.16 | 11.50 |
| 15.5 | 0.579 | 109.4 | 2.822 | -24.6 | 0.118 | -19.9 | 0.235 | 102.0 | 1.14 | 11.49 |
| 16.0 | 0.595 | 104.0 | 2.753 | -30.6 | 0.120 | -22.0 | 0.264 | 100.0 | 1.11 | 11.57 |
| 16.5 | 0.625 | 97.3 | 2.685 | -37.0 | 0.121 | -25.5 | 0.297 | 94.1 | 1.07 | 11.87 |
| 17.0 | 0.652 | 89.6 | 2.601 | -43.8 | 0.123 | -30.4 | 0.317 | 88.4 | 1.03 | 12.17 |
| 17.5 | 0.688 | 82.2 | 2.505 | -50.8 | 0.124 | -34.2 | 0.345 | 82.5 | .98 | 11.31 |
| 18.0 | 0.709 | 75.3 | 2.372 | -57.2 | 0.122 | -37.3 | 0.383 | 76.2 | .99 | 11.22 |

Note:

1. Gain Calculation:

$$\text{MAG} = \frac{|S_{21}|}{|S_{12}|} \left(K \pm \sqrt{K^2 - 1} \right). \text{ When } K \leq 1, \text{ MAG is undefined and MSG values are used. } \text{MSG} = \frac{|S_{21}|}{|S_{12}|}, K = \frac{1 + |\Delta|^2 - |S_{11}|^2 - |S_{22}|^2}{2 |S_{12} S_{21}|}, \Delta = S_{11} S_{22} - S_{21} S_{12}$$

MAG = Maximum Available Gain

MSG = Maximum Stable Gain

NONLINEAR MODEL

SCHEMATIC

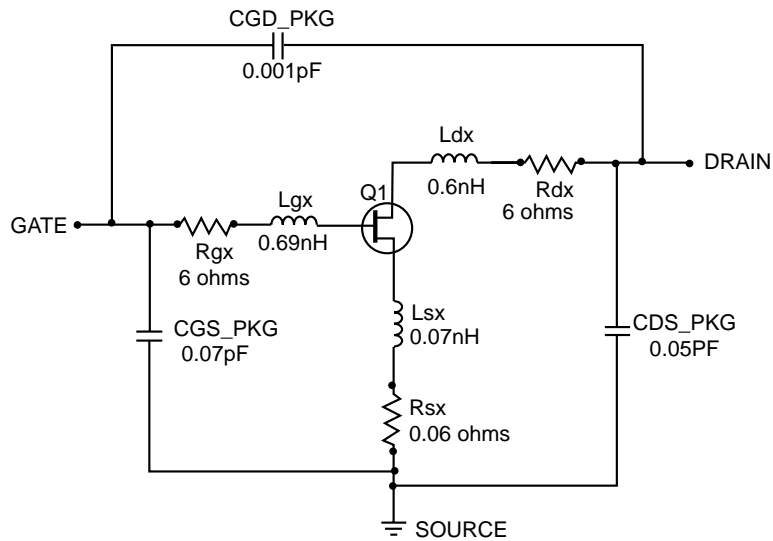

FET NONLINEAR MODEL PARAMETERS ⁽¹⁾

| Parameters | Q1 | Parameters | Q1 |
|------------|----------|------------|------|
| VTO | -0.8 | RG | 3 |
| VTOSC | 0 | RD | 2 |
| ALPHA | 8 | RS | 2 |
| BETA | 0.103 | RGMET | 0 |
| GAMMA | 0.092 | KF | 0 |
| GAMMADC | 0.08 | AF | 1 |
| Q | 2 | TNOM | 27 |
| DELTA | 1 | XTI | 3 |
| VBI | 0.715 | EG | 1.43 |
| IS | 3e-13 | VTOTC | 0 |
| N | 1.22 | BETATCE | 0 |
| RIS | 0 | FFE | 1 |
| RID | 0 | | |
| TAU | 4e-12 | | |
| CDS | 0.13e-12 | | |
| RDB | 5000 | | |
| CBS | 1e-9 | | |
| CGSO | 0.3e-12 | | |
| CGDO | 0.02e-12 | | |
| DELTA1 | 0.3 | | |
| DELTA2 | 0.1 | | |
| FC | 0.5 | | |
| VBR | Infinity | | |

UNITS

| Parameter | Units |
|-------------|---------|
| time | seconds |
| capacitance | farads |
| inductance | henries |
| resistance | ohms |
| voltage | volts |
| current | amps |

MODEL RANGE

Frequency: 0.1 to 18 GHz
 Bias: $V_{DS} = 1\text{ V to }3\text{ V}$, $I_D = 5\text{ mA to }30\text{ mA}$
 $I_{DSS} = 59.9\text{ ma @ }V_{GS} = 0, V_{DS} = 2\text{ V}$
 Date: 2/98

(1) Series IV Libra TOM Model

OUTLINE DIMENSIONS (Units in mm)

PACKAGE OUTLINE S01

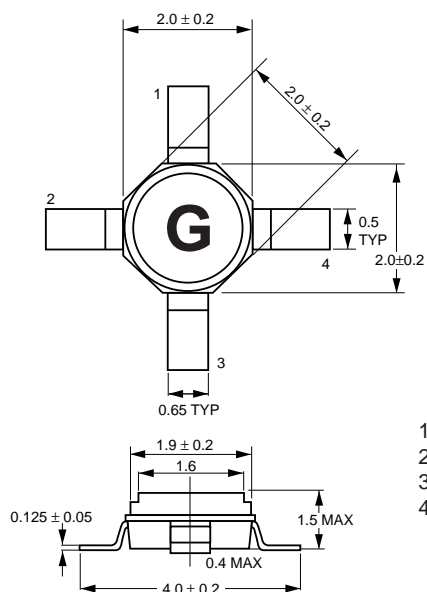

1. Source
2. Drain
3. Source
4. Gate

TYPICAL NOISE PARAMETERS (T_A = 25°C)

V_{DS} = 2 V, I_D = 10 mA

| FREQ. (GHz) | NF _{MIN} (dB) | G _A (dB) | Γ _{OPT} | | R _n /50 |
|----------------|---------------------------|------------------------|------------------|------|--------------------|
| | | | MAG | ANG | |
| 2 | 0.31 | 19.7 | 0.93 | 14 | 0.38 |
| 4 | 0.34 | 17.7 | 0.80 | 29 | 0.33 |
| 6 | 0.40 | 16.0 | 0.65 | 48 | 0.25 |
| 8 | 0.45 | 14.4 | 0.49 | 72 | 0.18 |
| 10 | 0.52 | 13.1 | 0.36 | 102 | 0.11 |
| 12 | 0.60 | 12.0 | 0.27 | 139 | 0.08 |
| 14 | 0.72 | 11.3 | 0.24 | -176 | 0.07 |
| 16 | 0.86 | 11.0 | 0.30 | -122 | 0.10 |
| 18 | 1.00 | 10.8 | 0.47 | -58 | 0.22 |

ORDERING INFORMATION

| PART NUMBER | SUPPLY FORM | PACKAGE OUTLINE |
|--------------|----------------------------|-----------------|
| NE425S01-T1 | Tape & Reel 1000 pcs./reel | S01 |
| NE425S01-T1B | Tape & Reel 4000 pcs./reel | S01 |

EXCLUSIVE NORTH AMERICAN AGENT FOR **NEC** RF, MICROWAVE & OPTOELECTRONIC SEMICONDUCTORS

CEL CALIFORNIA EASTERN LABORATORIES • Headquarters • 4590 Patrick Henry Drive • Santa Clara, CA 95054-1817 • (408) 988-3500 • Telex 34-6393 • FAX (408) 988-0279

24-Hour Fax-On-Demand: 800-390-3232 (U.S. and Canada only) • Internet: <http://WWW.CEL.COM>

DATA SUBJECT TO CHANGE WITHOUT NOTICE

 PRINTED IN USA ON RECYCLED PAPER -3/98