



# USAR HulaPoint™ - Ergonomic Mouse PS2/RS232 Encoder

A Semtech Company

Mature  
USAR MouseCoder™ family  
product specifications

## Description

The USAR HulaCoder™ UR7HCDMP is an easy-to-use single-chip encoder that interfaces an innovative sensor developed by Fujitsu. Together they make the USAR HulaPoint™. Equipped with an advanced motion algorithm, the UR7HCDMP offers low power consumption in a small footprint package. The device can be linked through either the serial or PS/2-type mouse port of the host system.

The UR7HCDMP is compatible with the IBM and Microsoft two-button and the Logitech three-button mouse communication protocols. The device will auto switch between the Serial and the PS/2 mouse communication protocol depending on the port to which the device is actually connected.

Communication through the serial port is half-duplex at a fixed speed of 1200 Baud. PS/2 communication is bidirectional at 10 kbps. The USAR HulaCoder™ implements all commands from and to the system, as defined in the IBM PS/2 Mouse Communication Protocol.

The UR7HCDMP is a CMOS device operating at 4 MHz. The low-power consumption of the IC makes it suitable for battery operated systems. Power in the serial mode, as in any standard mouse, can be drawn from the RS232 lines of the host system.

Custom versions are available to suit a wide range of pointing device applications.

Copyright 1999-2000 USAR Systems, Inc. All rights reserved.

## Features

- Equipped with Advanced Motion Control algorithm
- Low power consumption in a 3 to 6 Volt operating range
- Effortless and accurate cursor control with 10 degree movement in every direction
- Compatible with IBM/Microsoft two-button and Logitech three-button mouse
- Works with innovative proprietary sensor technology developed by Fujitsu Microelectronics
- Responds to feather-light touch without resistance
- Small 18 pin plastic PDIP and SOIC Packages available
- Autoselectable RS232 or P7S/2 hardware interface
- Customized versions available

## Applications

- Embedded HulaPoints
- Industrial Panels
- Instrumentation

## Pin Descriptions

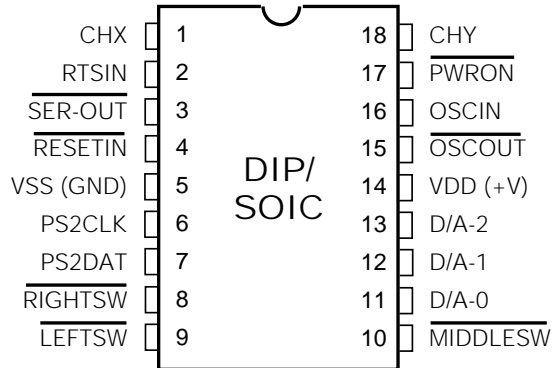

Ordering Code

Package options	TA=0°C TO +70°C	TA=40°C TO +85°C
18-pin, Plastic Dip	UR7HCDMP-P	UR7HCDMP-CP
18-pin, SOIC	UR7HCDMP-DW	UR7HCDMP-CDW

Functional Description

The UR7HCDMP consists functionally of five major sections (see Functional Diagram below). These are the Sensor Interface, the Sixteen Bit Timer, the Oscillator Circuit, the PS/2 Communication Port and the RS232 Communication Port. All sections communicate with each other and operate concurrently.

Functional Diagram

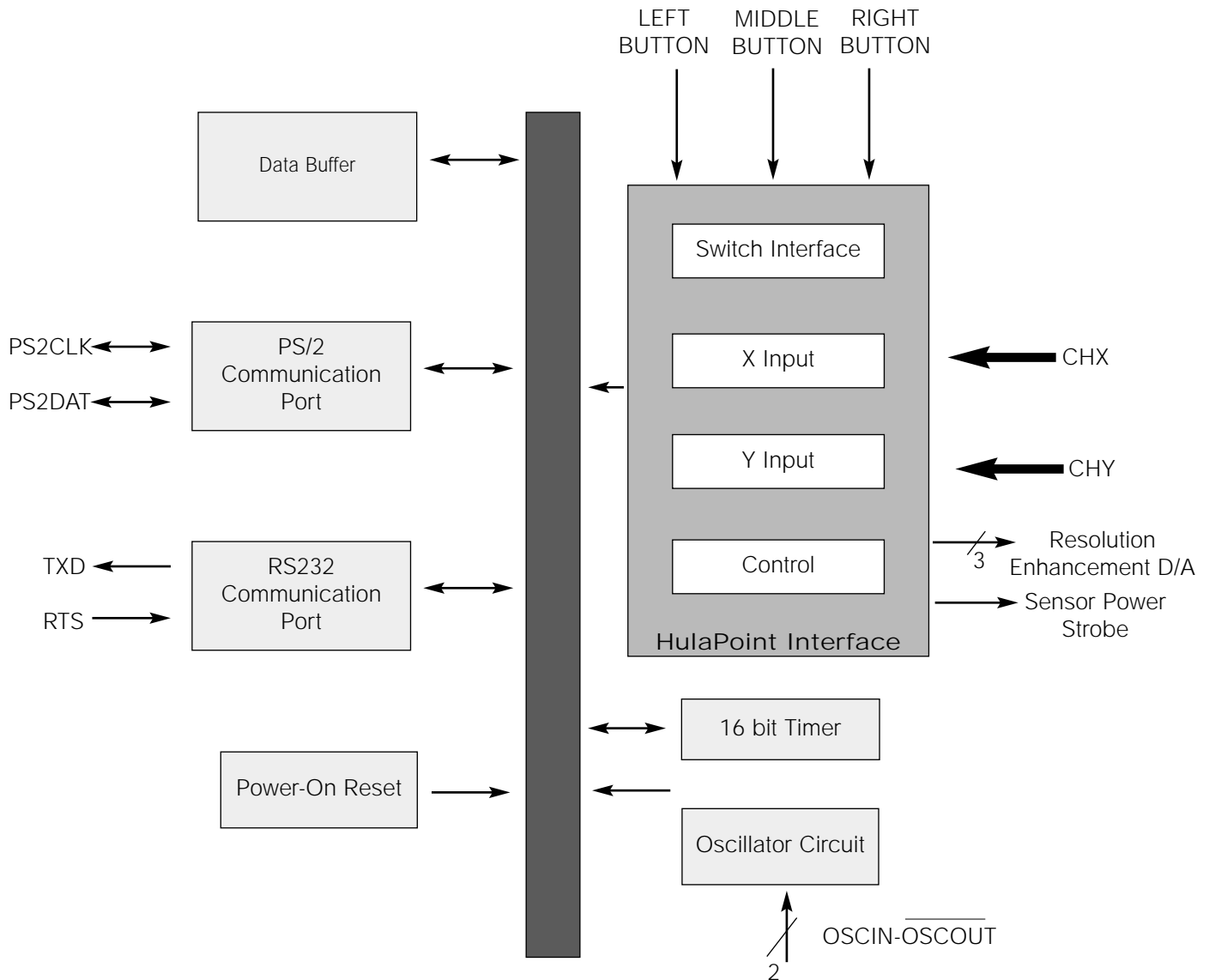

## Autoselect

At power-up the USAR HulaCoder™ will execute a power-on reset and determine the mode of operations.

## PS/2 Mode

At start-up or upon receiving a reset command, Clock and Data lines of the USAR HulaCoder™ can be pulled to a positive level. The UR7HCDMP will then wait between 300 and 500 milliseconds before sending an AAh to the host followed by a device ID of 00h. Then the IC will set itself to its default values, i.e. Incremental Stream Mode with 1:1 scaling, and a report rate of 100 Hz. The device will then disable itself until a command is sent from the host.

## Error Handling

For every correct command or parameter received from the host, the UR7HCDMP sends an Acknowledge (FAh). If an invalid command or parameter is received, the UR7HCDMP issues a Resend Request (FEh). If an invalid input is again received, the device transmits an Error Code (FCh) to the host. Both Error and Resend Request responses are sent by the device within 25 milliseconds. The host may not issue any new commands until either the USAR HulaCoder™ has responded or until 25 milliseconds have elapsed.

## Pin Description

### Pin Numbers

Mnemonic	DIP	SOIC	TYPE	Name and Function
CHX	1	1	Analog Input	Horizontal Input
RTSIN	2	2	I/O	RTS Sense, Power Save Out
SEROUT	3	3	O, Open Drain	<b>Serial Tx Data</b>
RESETIN	4	4	I	Reset: apply 0 V for orderly start up.
GND	5	5	Power	Ground
PS2CLK	6	6	I/O	PS/2 Clock
PS2DAT	7	7	I/O	PS/2 Data
RIGHTSW	8	8	I w/ Pullup	Right Switch: Low = On.
LEFTSW	9	9	I w/ Pullup	Left Switch: Low = On.
MIDDLESW	10	10	I w/ Pullup	Middle Switch: Low=On.
D/A-0	11	11	O	Resolution enhancement D/A: LSB.
D/A-1	12	12	O	Resolution enhancement D/A
D/A-2	13	13	O	Resolution enhancement D/A: MSB.
VCC	14	14	Power	Power Supply
OSCOUT	15	15	O	Oscillator Output
OSCIN	16	16	I	<b>Oscillator Input</b>
PWRON	17	17	O	Sensor Power Strobing Control
CHY	18	18	Analog Input	Vertical Input

## Pin Description Notes

The Internal Oscillator has a built-in feedback resistor. Only one (1) external component is needed for Clock generation. USAR recommends a 4.00 MHz Ceramic Resonator with built-in load capacitors.

RIGHTSW, LEFTSW, and MIDDLESW inputs have built-in pull-up resistors. No additional components are required for a three-button design. However, if high levels of ESD and EMI are expected, than series protection resistors (47 Ohms to 1k Ohms) are recommended between the switches and the switches' inputs on the IC.

---

## PS/2 Mode Commands

When the **Reset Command** (FFh) is enacted, the UR7HCDMP sets the following default parameters: Incremental Stream Mode, 1:1, scaling, disabled, and a report rate of 100 Hz and then sends AAh to the host followed by a device ID of 00h.

The host sends the **Resend Last Data Stream Command** (FEh) when it detects an error in any UR7HCDMP transmission. The device then resends the last output data stream to the host. This transmission occurs after a USAR HulaCoder™ transmission and before the host enables the interface allowing the next USAR HulaCoder™ output.

The **Set Default Status Command** (F6h) re-initializes the device to its condition at power-up.

The **Disable Command** (F5h) stops the device from transmitting all reports. However, the mode does not change; the HulaCoder™ is still able to respond to commands. If the **Disable Command** is issued while the device is transmitting a report, the UR7HCDMP immediately stops the transmission and disables itself.

If the USAR HulaCoder™ is in Incremental Stream Mode, the **Enable Command** (F4h) will allow it to begin data transmission. If the device is in Prompt Mode, the **Enable Command** will update the internal status of the USAR HulaCoder™, but will not allow the device to transmit data to the host either while it is moving or when a button is depressed.

---

## PS/2 Data Format

The following table shows the data report format. Values are expressed in a Two's Complement Format with a separate sign bit. If there is an overflow of the accumulator, the maximum positive or negative count is reported and the corresponding overflow bit is set.

### Byte 1

b0	Left Button status	1 = depressed
b1	Right Button Status	1 = depressed
b2	Middle Button Status	1 = depressed
b3	Always = 1	
b4	X data sign	1 = negative
b5	Y data sign	1 = negative
b6	X data overflow	1 = overflow
b7	Y data overflow	1 = overflow

### Byte 2

b0	X0: LSB of X data
b1	X1
b2	X2
b3	X3
b4	X4
b5	X5
b6	X6
b7	X7: MSB of X data

### Byte 3

b0	Y0: LSB of Y data
b1	Y1
b2	Y2
b3	Y3
b4	Y4
b5	Y5
b6	Y6
b7	Y7: MSB of Y data

### Status Report Format Table

#### Byte 1

b0	Right Button	1 = depressed
b1	Middle Button	1 = depressed
b2	Left Button	1 = depressed
b3	Always = 0	
b4	Scaling - 1:1 (0) / 2:1 (1)	
b5	Disable - (0) / enable (1)	
b6	Stream - (0) / prompt (1) mode	
b7	Always = 0	

#### Byte 2

b0 - 1 Current resolution setting  
 b2 - 7 Always = 0

#### Byte 3

b0-7 Current sampling rate

---

## PS/2 Mode Commands, Cont

The USAR HulaCoder™ will respond to the **Set Sampling Rate Command (F3h)** in both Stream and Prompt Modes, but will only update its internal status if the command is enacted while the device is in Stream Mode

The UR7HCDMP responds to the the **Read Device Type Command (F2h)** immediately after the Acknowledge with a 00h.

The **Set Prompt (Remote) Mode Command (F0h)** sets the device to Prompt Mode. Data values are then only reported in response to a **Read Report Command (EBh)**.

If the **Set Echo Mode Command (EEh)** is enacted, the USAR HulaCoder™ will immediately return any data bytes except FF or EC.

The **Reset Echo Mode Command (ECh)** returns the device to its previous mode - disabled. If this command occurs while the UR7HCDMP is in either Stream or Prompt Modes, the command is ignored.

The **Read Report Command (EBh)** prompts the USAR HulaCoder™ for a report. The report occurs even if the device did not move or if the status of the switches did not change. The report is sent by the UR7HCDMP following an Acknowledge.

The **Set Incremental Stream Mode Command (EAh)** sets the USAR HulaCoder™ to Stream Mode and disables the device.

---

## Sequential Commands

Unlike normal commands, sequential commands must be enacted with a sequence of commands. If the sequence is not consecutive or is incorrect, the USAR HulaCoder™ aborts the detection and responds the way it would normally respond to a command.

The individual commands that comprise a sequential command have been designed so that the elements of a sequential command can be sent to the USAR HulaCoder™ via the standard IBM PS/2 BIOS calls and the device only returns a valid response to the Standard Status Request. This ensures that, if the sequential command is sent via the BIOS, the status response will be accurately returned even if the BIOS does error detection. Thus, a programmer can have complete control of the mouse without having to access the device hardware port directly.

The USAR HulaCoder™ implements a special sequential command that can be used to determine its ability to report three buttons. The sequential command is a series of commands to the USAR HulaCoder™ that cause the device to respond to the last command (Read Status) with alternate information.

Sequence of commands:

1. Set Resolution = one count/ mm  
Direct: E8H,00H    BIOS: INT15H, AX=C203H, BX=0
2. Set Scaling = 1:1  
Direct: E6H        BIOS: INT15H, AX=C206H, BX=1
3. Set Scaling = 1:1  
Direct: E6H        BIOS: INT15H, AX=C206H, BX=1
4. Set Scaling = 1:1  
Direct: E6H        BIOS: INT15H, AX=C206H, BX=1
5. Read Status  
Direct: E9H        BIOS: INT15H, AX=C206H, BX=0

The response to the Read Status Command is in the form:

Byte 1: Standard Status Information (buttons, scaling, etc.)

Byte 2: Number of mouse buttons (3)

---

PS/2 Mode Commands, Cont.

The Status Request Command (E9h) returns a 3 byte status report.

The Set Resolution Command (E8h) controls resolution, and the Set 2:1 Scaling Command (E7h) enables a coarse/fine tracking response. Due to the Advanced Motion Algorithm, Set Resolution and Scaling Command are acknowledged and reported as activated, but their status is ignored. The Set 1:1 Scaling Command (E6h) enables the values of movements to be transmitted to the host without any scaling

---

Serial Mode

Communication through the serial port is half-duplex at a fixed speed of 1200 Baud, 7N2 protocol.

At start-up and after each RTS toggle the USA HulaCoder™ will send a two-character ASCII string "M3" indicating 3-button capability to the host.

A Data Report is sent if motion is detected, or if buttons are pressed or released. Motion is reported relative to the last Report sent, in a Two's Complement Form and eight (8) bit resolution. In other words, the Maximum Motion values are -128 to +127, saturated at min/max for faster speeds. Byte 4 is sent only if the middle button is pressed, held-down, or released.

---

Serial Data Report Format Table

Byte 1		
b0	X6	
b1	X7: MSB of X Data	
b2	Y6	
b3	Y7: MSB of Y Data	
b4	Right Button Status	1 = depressed
b5	Left Button Status	1 = depressed
b6	Always=1	
Byte 2		
b0	X0: LSB of X data	
b1	X1	
b2	X2	
b3	X3	
b4	X4	
b5	X5	
b6	Always=0	
Byte 3		
b0	Y0: LSB of Y data	
b1	Y1	
b2	Y2	
b3	Y3	
b4	Y4	
b5	Y5	
b6	Always=0	
Byte 4		
b0 - 4	Always = 0	
b5	Middle Button Status 1=depressed	
b6	Always=0	

HulaPoint™ Sensor Dimensions

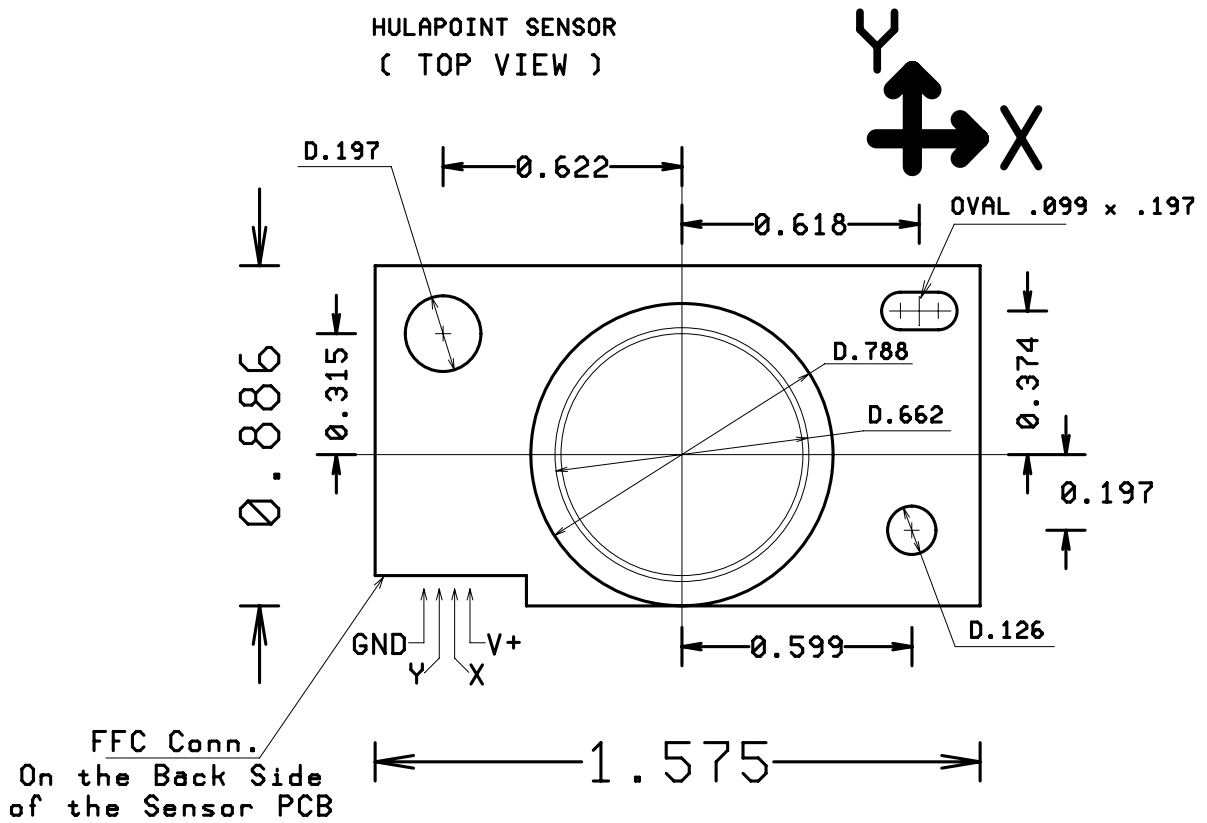

HulaPoint™ Evaluation Board Mechanical

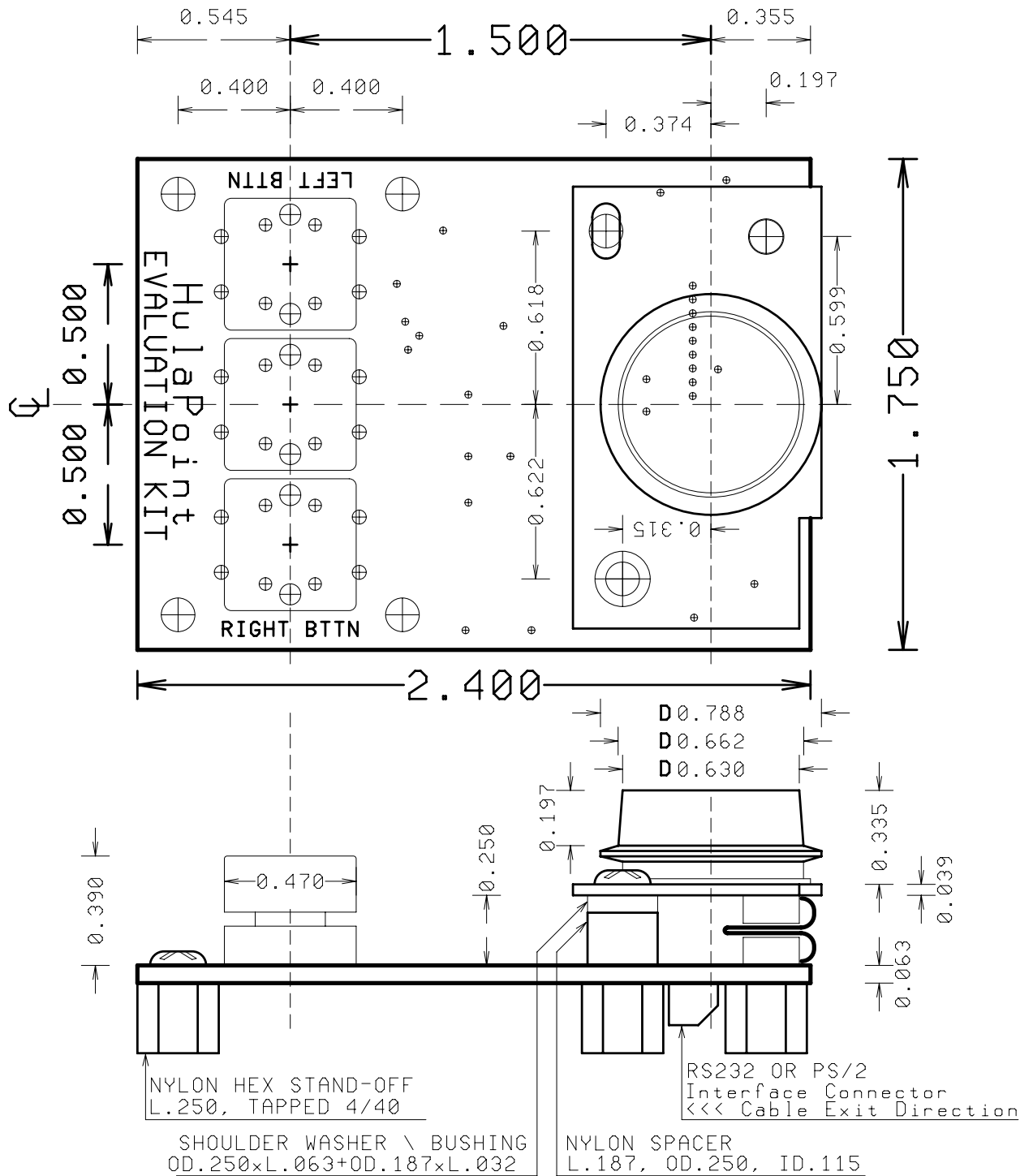



HulaPoint™ Alternate Kit with Rubber Overlay Material

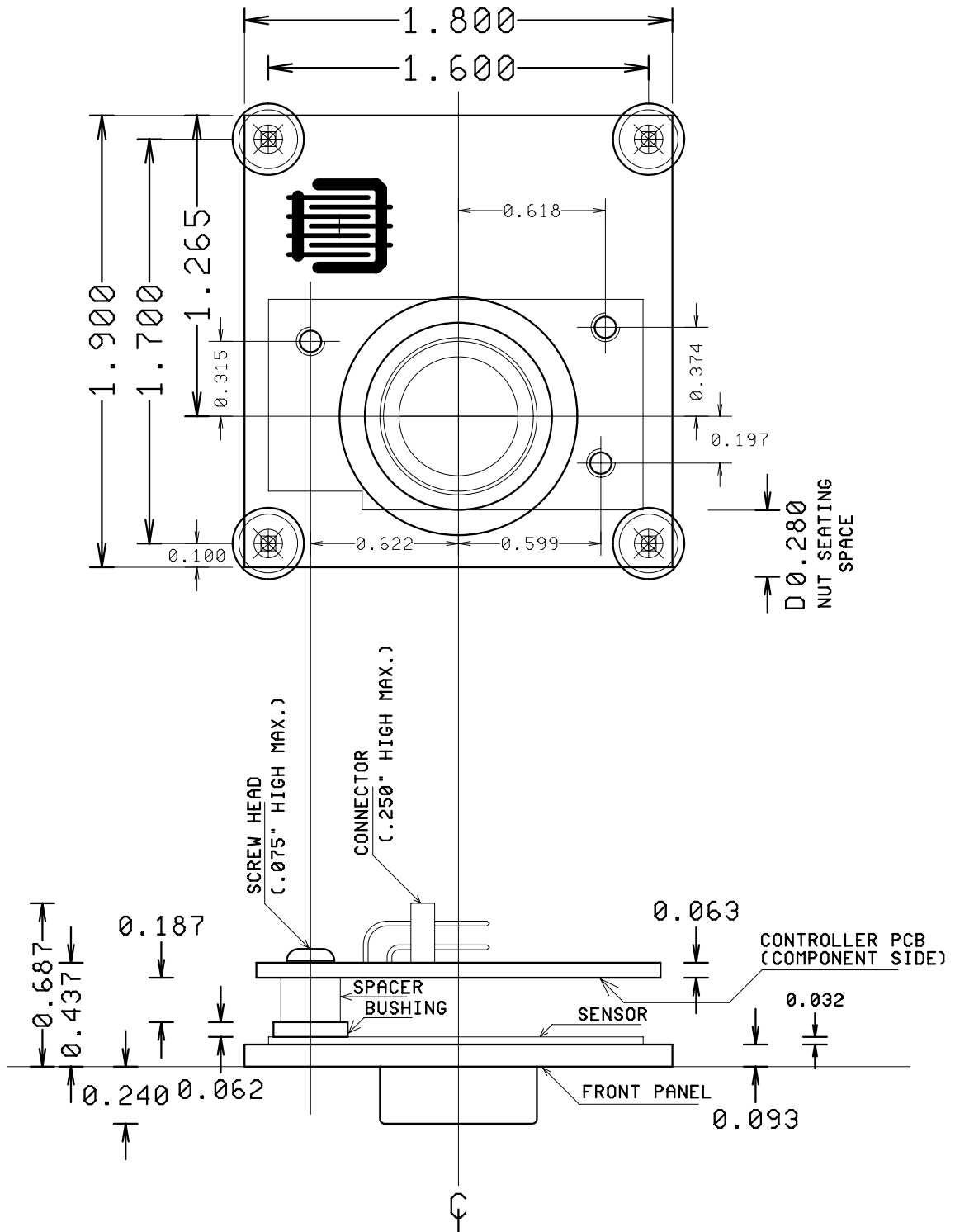

Sample Schematic

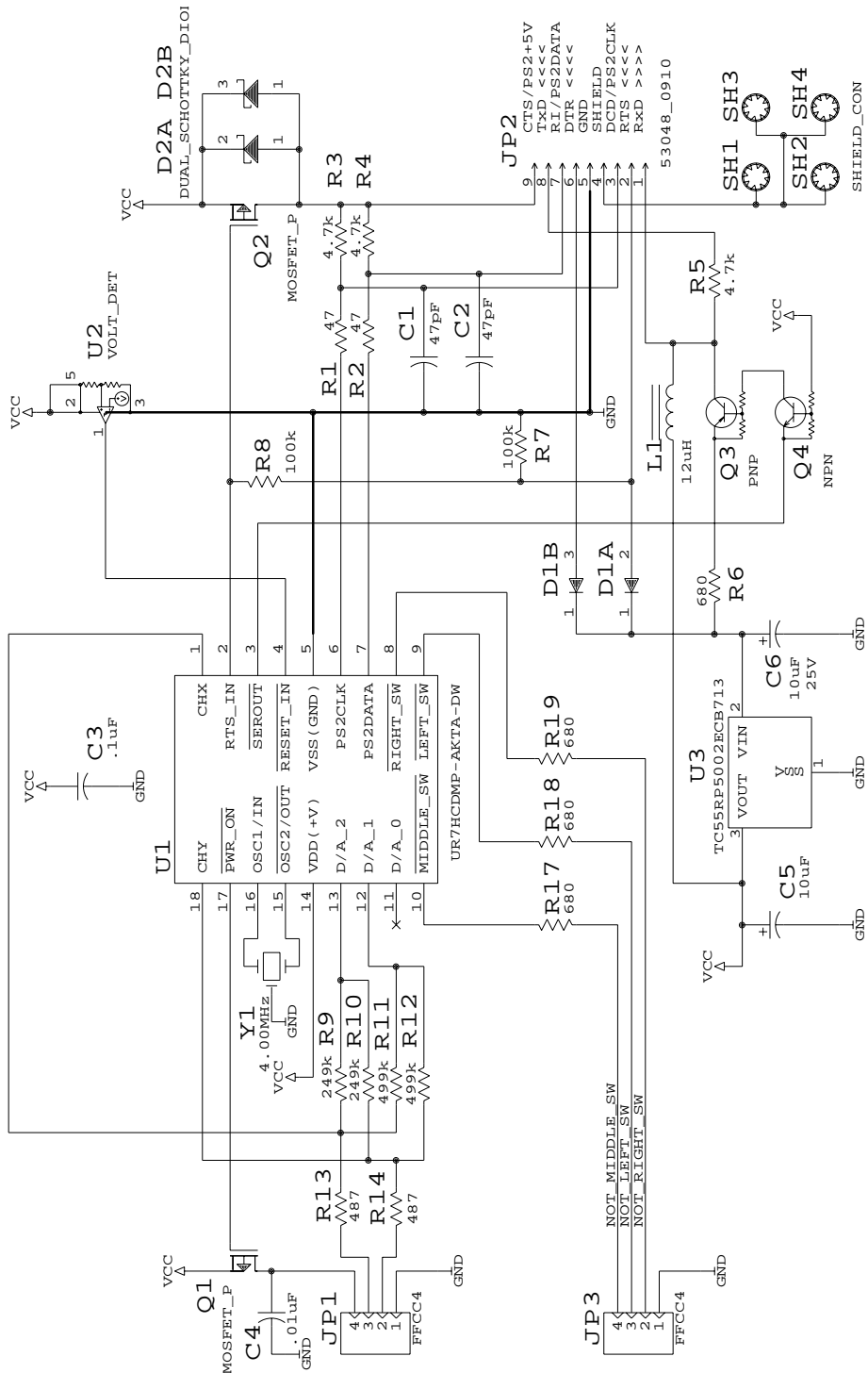

## Electrical Specifications for UR7HCDMP

### Absolute Maximum Ratings

Ratings	Symbol	Value	Unit
Supply Voltage	Vdd	0 to 7.5	V
Input Voltage	Vin	Vss -0.6 to Vdd +0.6	V
Current Drain per Pin (not including Vss or Vdd)	I	20	mA
Operating Temperature UR7HCDMP-xx UR7HCDMP-Cxx	Ta	T low to T high 0 to +70 -40 to +85	° C
Storage Temperature Range	Tstg	-65 to +150	° C
Ambient Temperature Under Bias	Tbias	-55 to +125	° C

### DC Electrical Characteristics, Temperature range=T low to T high unless otherwise noted)

Characteristic	Symbol	Min	Typ	Max	Unit
Supply Voltage		3.0	5.0	6.0	V
Output Voltage	Voh Vol	Vdd-0.1		0.1	V
Input High Voltage	Vih	0.7xVdd	Vdd		V
Input Low Voltage	Vil	Vss		0.2xVdd	V
Input Current	Iin			+/- 1	uA
Internal Pull-up Current	Ipup	50	250	500	uA
Supply Current Vdd=0 Vdc+/-10%, Vss=0	Idd		2.0	3.5	mA5.

### Control Timing (Vdd=5.0 Vdc +/-10%, Vss=0 Vdc, Temperature range=T low to T high unless otherwise noted)

Characteristic	Symbol	Min	Typ	Max	Unit
Frequency of Operation	fosc				MHz
■ Crystal Option			4.0		
■ External Clock Option			4.0		

For sales information  
and product literature,  
contact:

USAR – A Semtech Company  
568 Broadway  
New York, NY 10012  
info@usar.com  
<http://www.usar.com>  
212 226 2042 Telephone  
212 226 3215 Telefax

In Japan:  
Semtech Japan  
Tel: 81-45-948-5925  
Fax: 81-45-948-5930

In Taiwan:  
Semtech Asia/Pacific Sales  
Tel: 011-886-2-2748-3380  
Fax: 011-886-2-2748-3390

Koryo Electronics Co., Ltd.  
Telephone +886-2-2698-1143  
E-mail alex.chen@koryo.com.tw

In Korea:  
Semtech Korea  
Tel: 011-82-2-527-4377  
Fax: 011-82-2-527-4376

In Europe  
Semtech Limited  
Tel: +44-1592-630350  
Fax: +44-1592-774781

Copyright 1999-2000 USAR – A Semtech Company. All rights reserved. HulaCoder, HulaPoint and MouseCoder are trademarks of USAR Systems, Inc. USAR and the USAR logo are registered trademarks of USAR – A Semtech Company. All other trademarks belong to their respective companies.

**INTELLECTUAL PROPERTY DISCLAIMER**  
This specification is provided "as is" with no warranties whatsoever including any warranty of merchantability, fitness for any particular purpose, or any warranty otherwise arising out of any proposal, specification or sample.

A license is hereby granted to reproduce and distribute this specification for internal use only. No other license, expressed or implied to any other intellectual property rights is granted or intended hereby. Authors of this specification disclaim any liability, including liability for infringement of proprietary rights, relating to the implementation of information in this specification. Authors of this specification also do not warrant or represent that such implementation(s) will not infringe such rights.