



# HERA801G THRU HERA808G

8.0 AMPS. Glass Passivated High Efficient Rectifiers



Voltage Range  
50 to 1000 Volts  
Current  
8.0 Amperes

## Features

- ◇ Low forward voltage drop
- ◇ High current capability
- ◇ High reliability
- ◇ High surge current capability

## Mechanical Data

- ◇ Cases: Molded plastic
- ◇ Epoxy: UL 94V-O rate flame retardant
- ◇ Terminals: Leads solderable per MIL-STD-202, Method 208 guaranteed
- ◇ Polarity: As marked
- ◇ High temperature soldering guaranteed: 250°C/10 seconds .16", (4.06mm) from case.
- ◇ Weight: 2.24 grams

### TO-220A

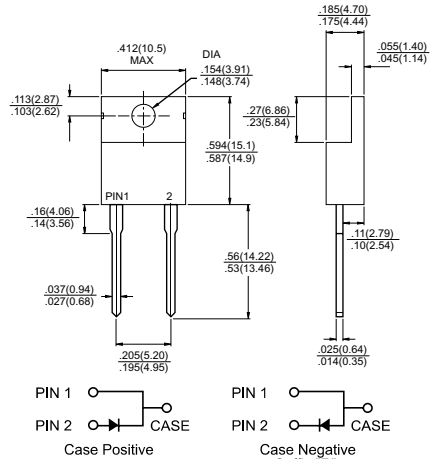

Dimensions in inches and (millimeters)

## Maximum Rating and Electrical Characteristics

Rating at 25°C ambient temperature unless otherwise specified.

Single phase, half wave 60 Hz, resistive or inductive load.

For capacitive load, derate current by 20%

Type Number	HERA 801G	HERA 802G	HERA 803G	HERA 804G	HERA 805G	HERA 806G	HERA 807G	HERA 808G	Units
Maximum Recurrent Peak Reverse Voltage	50	100	200	300	400	600	800	1000	V
Maximum RMS Voltage	35	70	140	210	280	420	560	700	V
Maximum DC Blocking Voltage	50	100	200	300	400	600	800	1000	V
Maximum Average Forward Rectified Current .375" (9.5mm) Lead Length @ T <sub>C</sub> = 100°C	8.0								A
Peak Forward Surge Current, 8.3 ms Single Half Sine-wave Superimposed on Rated Load (JEDEC method)	150								A
Maximum Instantaneous Forward Voltage @ 8.0A	1.0			1.3		1.7			V
Maximum DC Reverse Current @ T <sub>A</sub> = 25°C at Rated DC Blocking Voltage @ T <sub>A</sub> = 125°C	10.0								uA
	400								uA
Maximum Reverse Recovery Time ( Note 1 )	50				80				nS
Typical Junction Capacitance ( Note 2 )	80				50				pF
Typical Thermal Resistance R <sub>θJC</sub> (Note 3)	3.0								°C/W
Operating Temperature Range T <sub>J</sub>	-65 to +150								°C
Storage Temperature Range T <sub>STG</sub>	-65 to +150								°C

Notes: 1. Reverse Recovery Test Conditions: I<sub>F</sub> = 0.5A, I<sub>R</sub> = 1.0A, I<sub>RR</sub> = 0.25A

2. Measured at 1 MHz and Applied Reverse Voltage of 4.0V D.C.

3. Thermal Resistance from Junction to Case Mounted on Heatsink.

## RATINGS AND CHARACTERISTIC CURVES (HERA801G THRU HERA808G)

FIG. 1- REVERSE RECOVERY TIME CHARACTERISTIC AND TEST CIRCUIT DIAGRAM

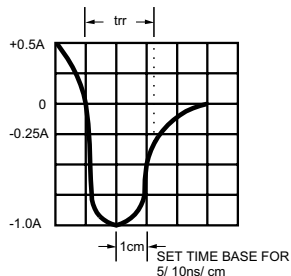
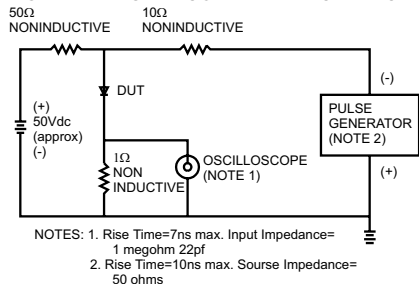

FIG. 2- MAXIMUM FORWARD CURRENT DERATING CURVE

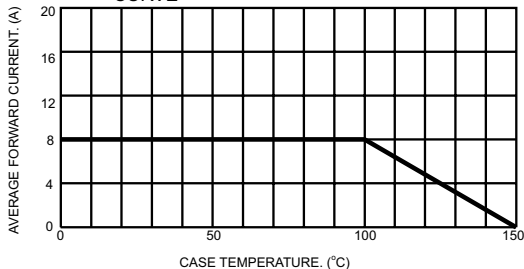

FIG. 3- TYPICAL REVERSE CHARACTERISTICS

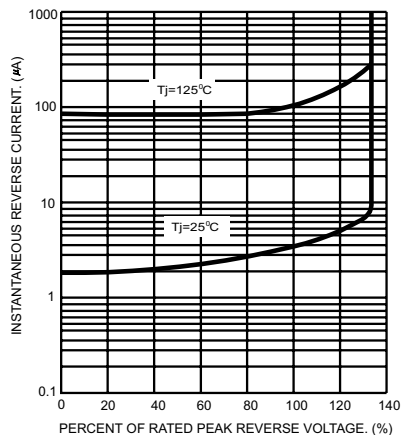

FIG. 4- MAXIMUM NON-REPETITIVE FORWARD SURGE CURRENT

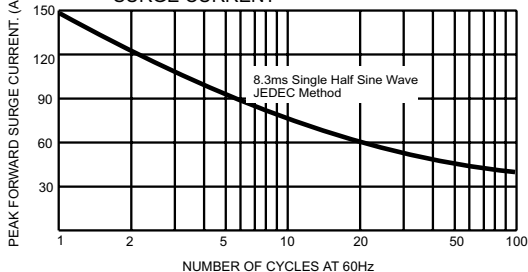

FIG. 6- TYPICAL FORWARD CHARACTERISTICS

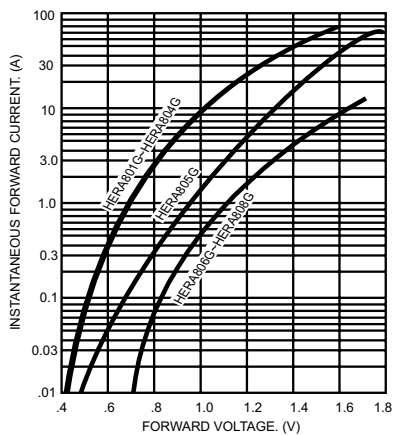

FIG. 5- TYPICAL JUNCTION CAPACITANCE

