

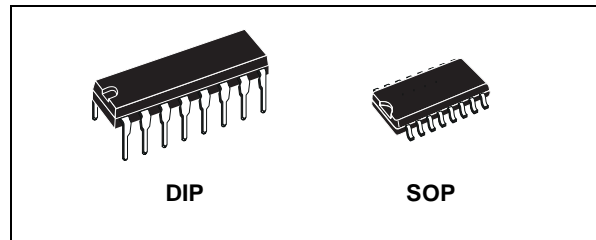

HCF4060B

14-STAGE RIPPLE CARRY BINARY COUNTER/DIVIDER AND OSCILLATOR

- MEDIUM-SPEED OPERATION
- COMMON RESET
- FULLY STATIC OPERATION
- BUFFERED INPUTS AND OUTPUTS
- QUIESCENT CURRENT SPECIFIED UP TO 20V
- 5V, 10V AND 15V PARAMETRIC RATINGS
- INPUT LEAKAGE CURRENT
 $I_l = 100\text{nA (MAX) AT } V_{DD} = 18\text{V } T_A = 25^\circ\text{C}$
- 100% TESTED FOR QUIESCENT CURRENT
- MEETS ALL REQUIREMENTS OF JEDEC JESD13B "STANDARD SPECIFICATIONS FOR DESCRIPTION OF B SERIES CMOS DEVICES"



ORDER CODES

PACKAGE	TUBE	T & R
DIP	HCF4060BEY	
SOP	HCF4060BM1	HCF4060M013TR

DESCRIPTION

The HCF4060B is a monolithic integrated circuit fabricated in Metal Oxide Semiconductor technology available in DIP and SOP packages. The HCF4060B consists of an oscillator section and 14 ripple carry binary counter stages. The oscillator configuration allows design of either RC or crystal oscillator circuits. A RESET input is provided which reset the counter to the all 0's

state and disable oscillator. A high level on the RESET line accomplishes the reset function. All counter stages are master slave flip-flops. The state of the counter is advanced one step in binary order on the negative transition of ϕ_1 (and ϕ_0). All inputs and outputs are fully buffered. Schmitt trigger action on the clock pin permits unlimited clock rise and fall time.

PIN CONNECTION

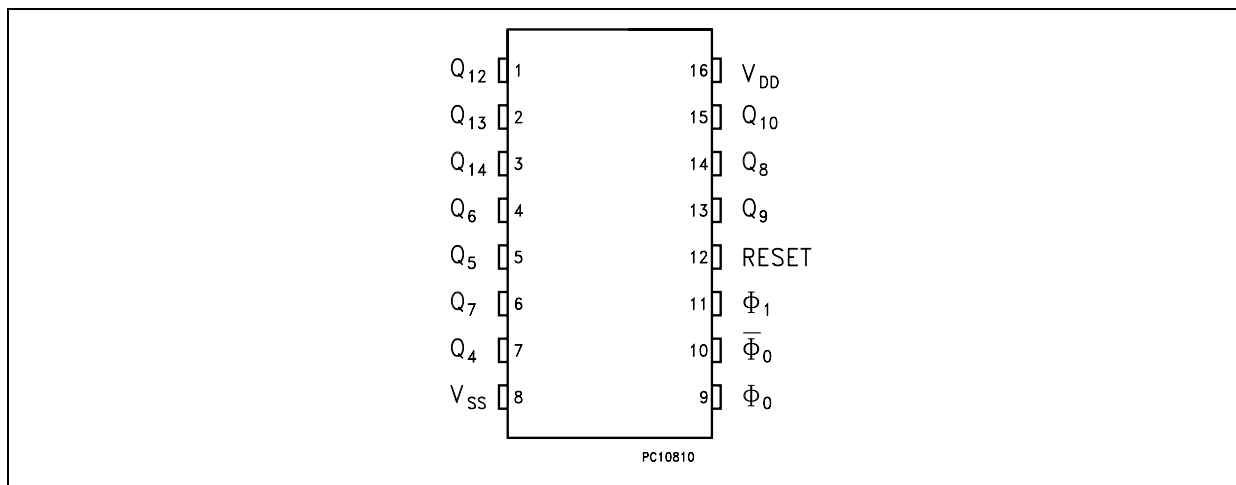

INPUT EQUIVALENT CIRCUIT

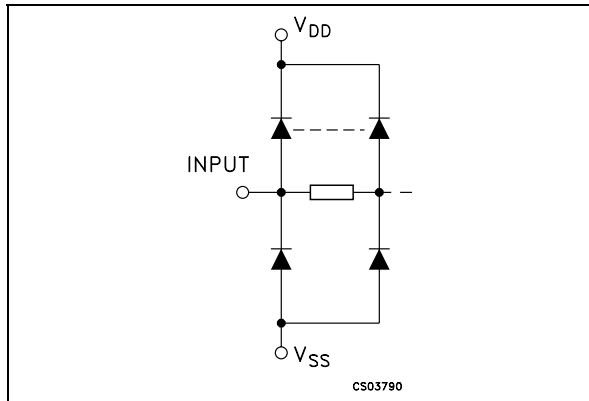

PIN DESCRIPTION

PIN No	SYMBOL	NAME AND FUNCTION
1, 2, 3, 4, 5, 6, 7, 13, 14, 15	$Q_{12}, Q_{13}, Q_{14}, Q_6, Q_5, Q_7, Q_4, Q_9, Q_8, Q_{10}$	Outputs
9, 10, 11	$\Phi_0, \bar{\Phi}_0, \Phi_1$	Oscillator Input
12	RESET	Reset
8	V_{SS}	Negative Supply Voltage
16	V_{DD}	Positive Supply Voltage

FUNCTIONAL DIAGRAM

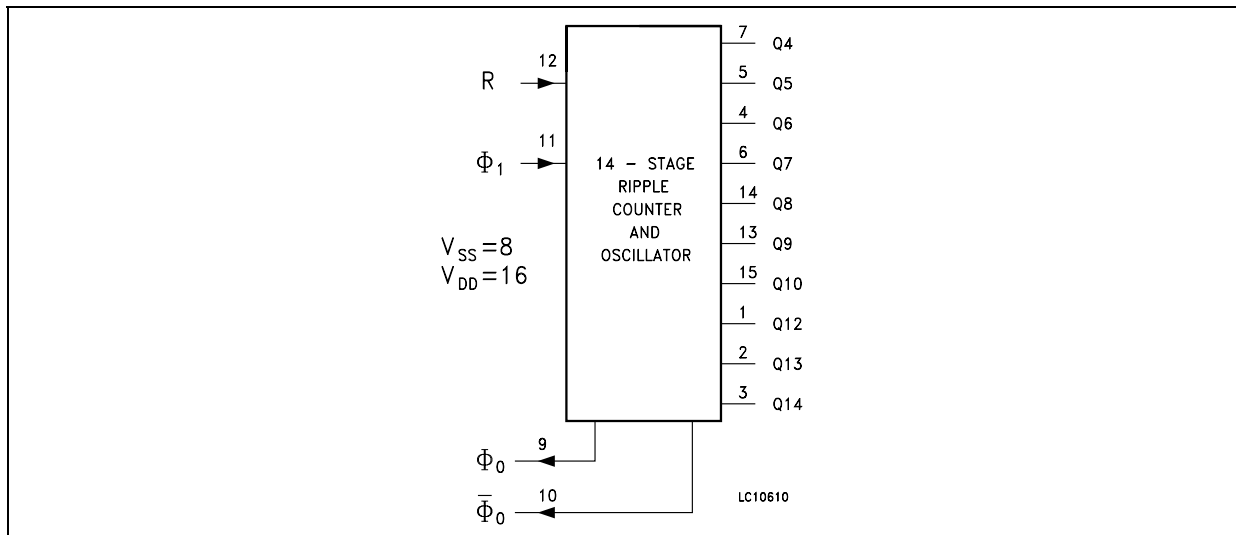

LOGIC DIAGRAM

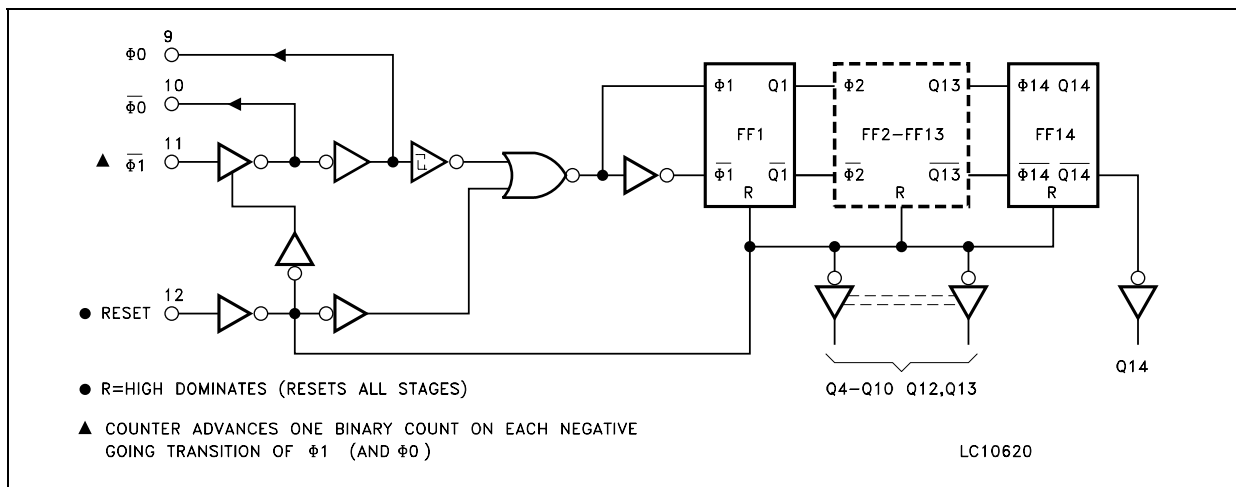

ABSOLUTE MAXIMUM RATINGS

Symbol	Parameter	Value	Unit
V_{DD}	Supply Voltage	-0.5 to +22	V
V_I	DC Input Voltage	-0.5 to $V_{DD} + 0.5$	V
I_I	DC Input Current	± 10	mA
P_D	Power Dissipation per Package	200	mW
	Power Dissipation per Output Transistor	100	mW
T_{op}	Operating Temperature	-55 to +125	°C
T_{stg}	Storage Temperature	-65 to +150	°C

Absolute Maximum Ratings are those values beyond which damage to the device may occur. Functional operation under these conditions is not implied.

All voltage values are referred to V_{SS} pin voltage.

RECOMMENDED OPERATING CONDITIONS

Symbol	Parameter	Value	Unit
V_{DD}	Supply Voltage	3 to 20	V
V_I	Input Voltage	0 to V_{DD}	V
T_{op}	Operating Temperature	-55 to 125	°C

DC SPECIFICATIONS

Symbol	Parameter	Test Condition				Value								Unit
		V _I (V)	V _O (V)	I _{OL} (μ A)	V _{DD} (V)	T _A = 25°C			-40 to 85°C		-55 to 125°C			
						Min.	Typ.	Max.	Min.	Max.	Min.	Max.		
I _L	Quiescent Current	0/5			5		0.04	5		5		150	μ A	
		0/10			10		0.04	10		10		300		
		0/15			15		0.04	20		20		600		
		0/20			20		0.08	100		100		3000		
V _{OH}	High Level Output Voltage	0/5		<1	5	4.95			4.95		4.95		V	
		0/10		<1	10	9.95			9.95		9.95			
		0/15		<1	15	14.95			14.95		14.95			
V _{OL}	Low Level Output Voltage	5/0		<1	5		0.05			0.05		0.05	V	
		10/0		<1	10		0.05			0.05		0.05		
		15/0		<1	15		0.05			0.05		0.05		
V _{IH}	High Level Input Voltage		0.5/4.5	<1	5	3.5			3.5		3.5		V	
			1/9	<1	10	7			7		7			
			1.5/13.5	<1	15	11			11		11			
V _{IL}	Low Level Input Voltage		4.5/0.5	<1	5			1.5		1.5		1.5	V	
			9/1	<1	10			3		3		3		
			13.5/1.5	<1	15			4		4		4		
I _{OH}	Output Drive Current	0/5	2.5	<1	5	-1.36	-3.2		-1.15		-1.1		mA	
		0/5	4.6	<1	5	-0.44	-1		-0.36		-0.36			
		0/10	9.5	<1	10	-1.1	-2.6		-0.9		-0.9			
		0/15	13.5	<1	15	-3.0	-6.8		-2.4		-2.4			
I _{OL}	Output Sink Current	0/5	0.4	<1	5	0.44	1		0.36		0.36		mA	
		0/10	0.5	<1	10	1.1	2.6		0.9		0.9			
		0/15	1.5	<1	15	3.0	6.8		2.4		2.4			
I _I	Input Leakage Current	0/18	Any Input		18		$\pm 10^{-5}$	± 0.3		± 0.3		± 1	μ A	
C _I	Input Capacitance		Any Input				5	7.5					pF	

The Noise Margin for both "1" and "0" level is: 1V min. with V_{DD}=5V, 2V min. with V_{DD}=10V, 2.5V min. with V_{DD}=15V

DYNAMIC ELECTRICAL CHARACTERISTICS ($T_{amb} = 25^{\circ}\text{C}$, $C_L = 50\text{pF}$, $R_L = 200\text{K}\Omega$, $t_r = t_f = 20\text{ ns}$)

Symbol	Parameter	Test Condition		Value (*)			Unit
		V_{DD} (V)		Min.	Typ.	Max.	
t_{TLH} t_{THL}	Output Transition Time	5			100	200	ns
		10			50	100	
		15			40	80	
t_{PLH} t_{PHL}	Propagation Delay Time (ϕ to Q_4 out)	5			370	740	ns
		10			150	300	
		15			100	200	
t_{PLH} t_{PHL}	Propagation Delay Time (Q_n to Q_{n+1})	5			100	200	ns
		10			50	100	
		15			40	80	
t_W	Input Pulse Width	5	$f = 100\text{ KHz}$		50	100	ns
		10			20	40	
		15			15	30	
t_r t_f	Input Pulse Rise and Fall Time	5		Unlimited			μs
		10					
		15					
f_{max}	Maximum Clock Input Frequency	5		3.5	7		MHz
		10		8	16		
		15		12	24		
RESET OPERATION							
t_{PHL}	Propagation Delay Time	5			180	360	ns
		10			80	160	
		15			50	100	
t_W	Input Pulse Width	5			60	120	ns
		10			30	60	
		15			20	40	
RC OPERATION							
	Variation of Frequency (Unit-to-Unit)	5	$C_x = 200\text{pF}$, $R_s = 560\text{K}\Omega$, $R_x = 50\text{K}\Omega$	18	21.5	25	KHz
		10		20	23	26	
		15		21.1	24	27	
	Variation of Frequency With Voltage Change (Same Unit)	5 to 10	$C_x = 200\text{pF}$, $R_s = 560\text{K}\Omega$, $R_x = 50\text{K}\Omega$			2	KHz
		10 to 15				1	
R_X		5	$C_x = 10\mu\text{F}$			20	M Ω
		10	$C_x = 50\mu\text{F}$			20	
		15	$C_x = 10\mu\text{F}$			10	
C_X		5	$R_x = 500\text{K}\Omega$			1000	mF
		10	$R_x = 300\text{K}\Omega$			50	
		15	$R_x = 300\text{K}\Omega$			50	
	Maximum Oscillator Frequency (**)	10	$R_x = 5\text{K}\Omega$, $C_x = 15\text{pF}$	530	650	810	pF
		15		690	800	940	

(*) Typical temperature coefficient for all V_{DD} values is 0.3 %/°C, all input rise and fall times = 20 ns.(**) RC Oscillator applications are not recommended at supply voltages below 7V for $R_x = 50\text{K}\Omega$

HCF4060B

DETAIL OF TYPICAL FLIP-FLOP STAGE

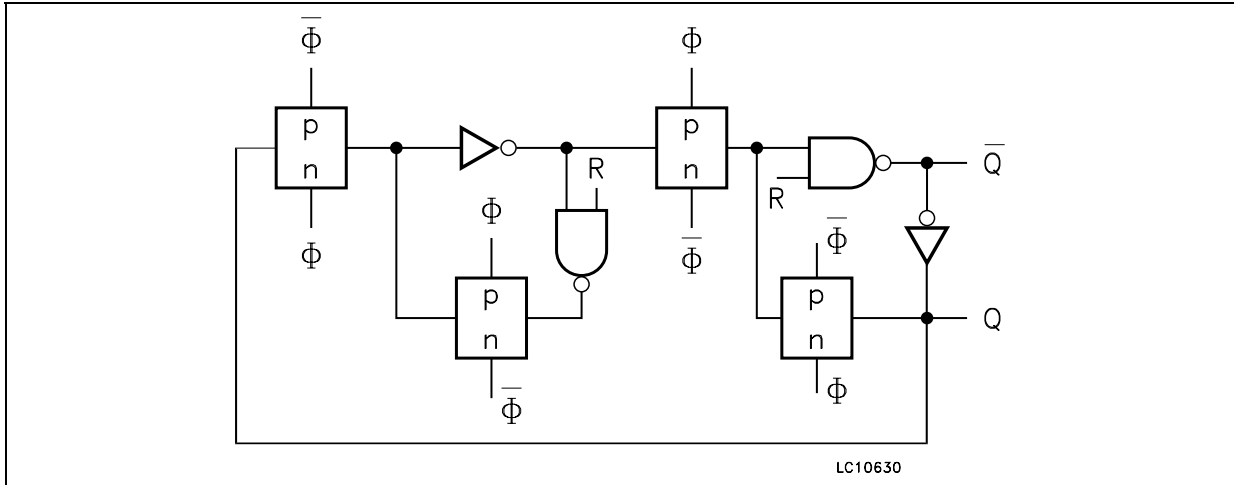

TYPICAL RC OSCILLATOR CIRCUIT

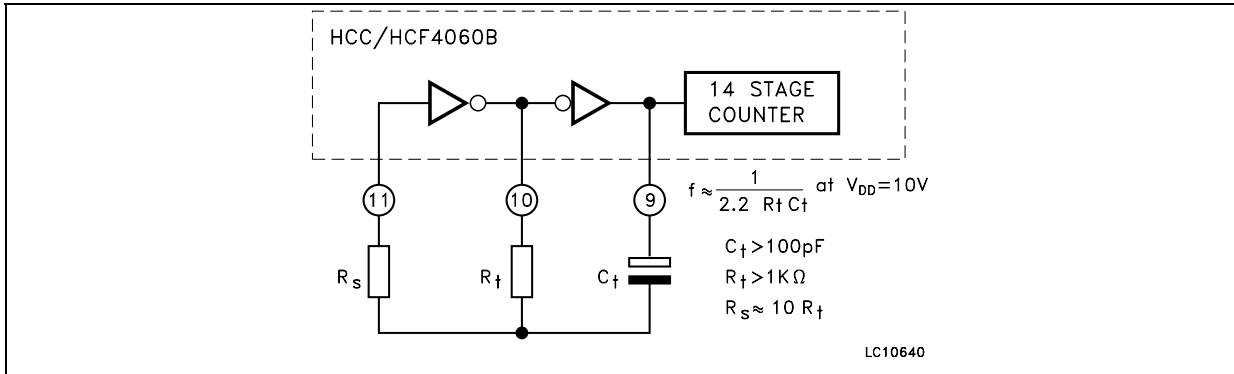

TYPICAL CRYSTAL OSCILLATOR CIRCUIT

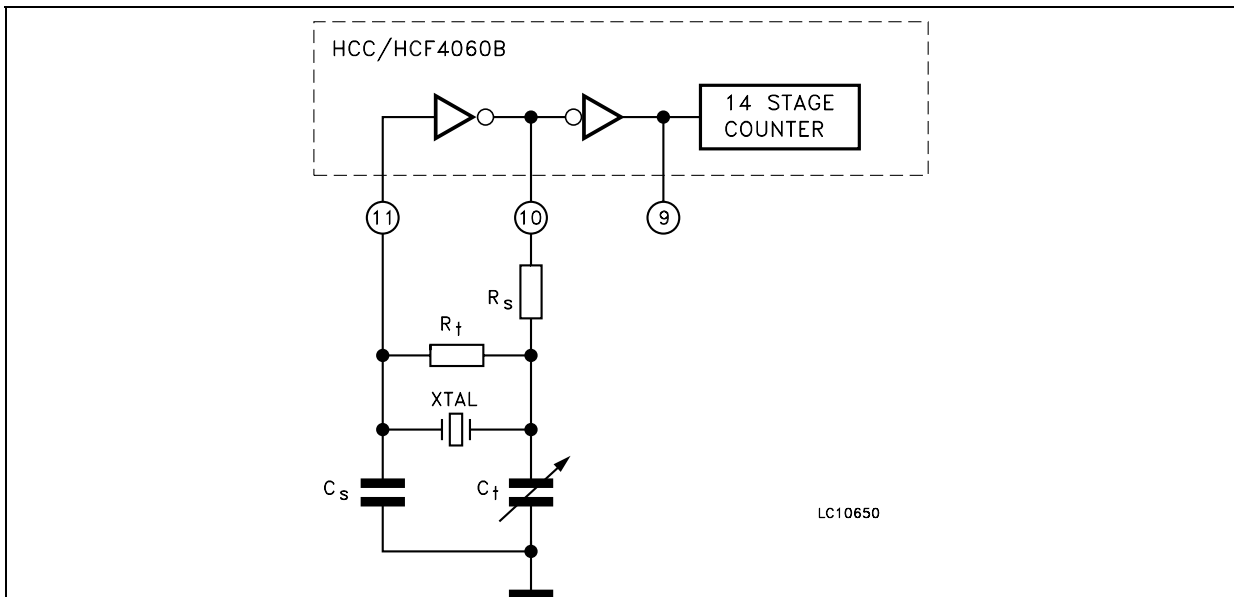

Plastic DIP-16 (0.25) MECHANICAL DATA

DIM.	mm.			inch		
	MIN.	TYP	MAX.	MIN.	TYP.	MAX.
a1	0.51			0.020		
B	0.77		1.65	0.030		0.065
b		0.5			0.020	
b1		0.25			0.010	
D			20			0.787
E		8.5			0.335	
e		2.54			0.100	
e3		17.78			0.700	
F			7.1			0.280
I			5.1			0.201
L		3.3			0.130	
Z			1.27			0.050

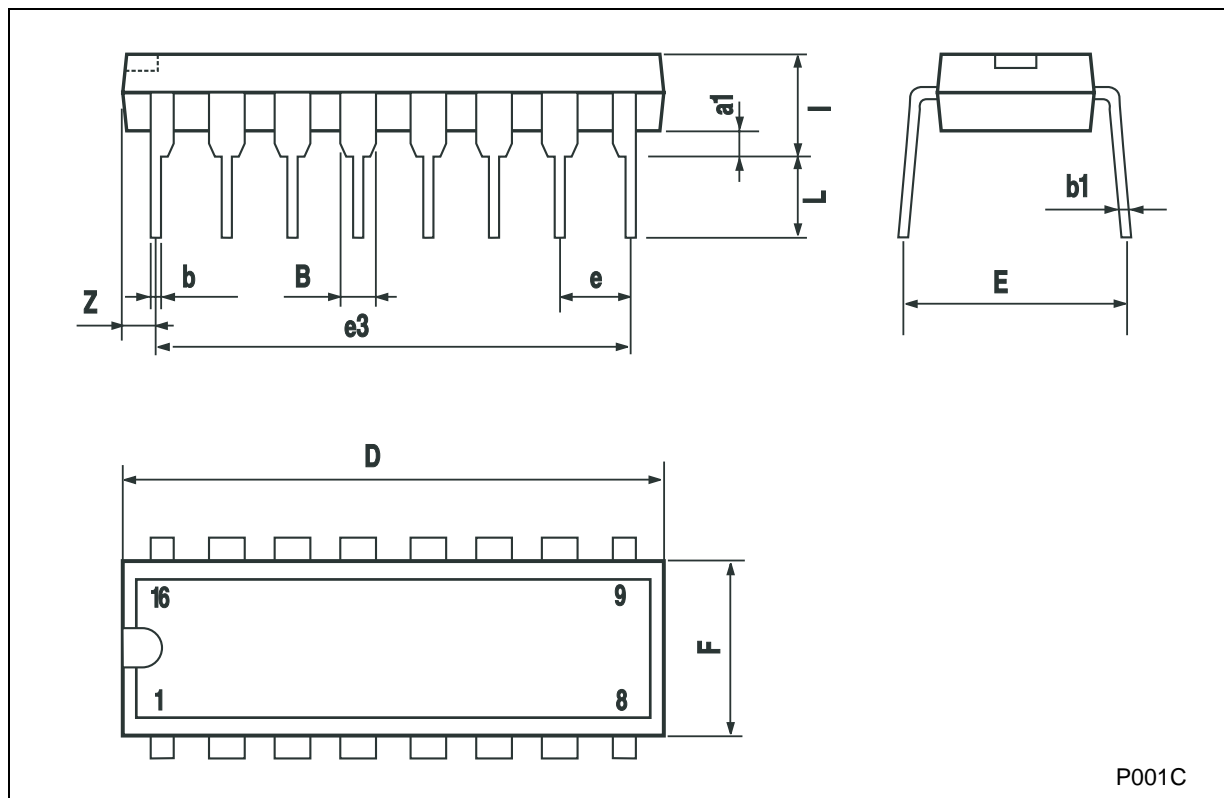

SO-16 MECHANICAL DATA

DIM.	mm.			inch		
	MIN.	TYP	MAX.	MIN.	TYP.	MAX.
A			1.75			0.068
a1	0.1		0.2	0.004		0.008
a2			1.65			0.064
b	0.35		0.46	0.013		0.018
b1	0.19		0.25	0.007		0.010
C		0.5			0.019	
c1	45° (typ.)					
D	9.8		10	0.385		0.393
E	5.8		6.2	0.228		0.244
e		1.27			0.050	
e3		8.89			0.350	
F	3.8		4.0	0.149		0.157
G	4.6		5.3	0.181		0.208
L	0.5		1.27	0.019		0.050
M			0.62			0.024
S	8			° (max.)		

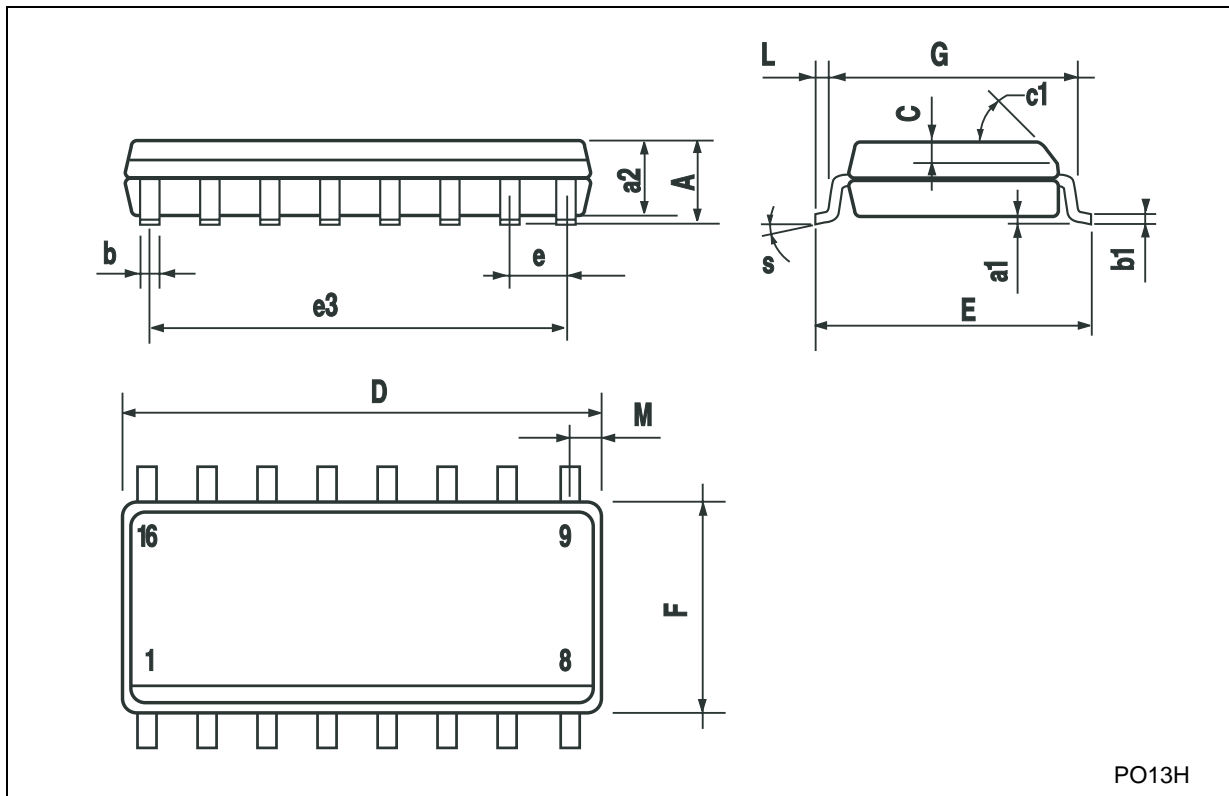

PO13H

Information furnished is believed to be accurate and reliable. However, STMicroelectronics assumes no responsibility for the consequences of use of such information nor for any infringement of patents or other rights of third parties which may result from its use. No license is granted by implication or otherwise under any patent or patent rights of STMicroelectronics. Specifications mentioned in this publication are subject to change without notice. This publication supersedes and replaces all information previously supplied. STMicroelectronics products are not authorized for use as critical components in life support devices or systems without express written approval of STMicroelectronics.

© The ST logo is a registered trademark of STMicroelectronics

© 2003 STMicroelectronics - Printed in Italy - All Rights Reserved
STMicroelectronics GROUP OF COMPANIES

Australia - Brazil - Canada - China - Finland - France - Germany - Hong Kong - India - Israel - Italy - Japan - Malaysia - Malta - Morocco
Singapore - Spain - Sweden - Switzerland - United Kingdom - United States.

© <http://www.st.com>

