

VI TELEFILTER**Filter Specification****TFS 456 C 1/4****Measurement condition**

Ambient temperature: 23 °C
 Input power level: 0 dBm
 Terminating impedance: 270 Ω || -1pF

Construction and pin connection

see page 2

50 Ω test circuit

see page 2

Characteristics**Remark:**

Reference level for the relative attenuation a_{rel} of the TFS 456 C is the maximum of the attenuation a_{max} . The maximum of the attenuation within the usable signal bandwidth is defined as the insertion loss a_e . The centre frequency f_o is the arithmetic mean value of the upper and lower frequencies at the 3dB filter attenuation level relative to the insertion loss a_e . The nominal frequency f_N is fixed on 456,49 MHz without tolerance. The given values for the relative attenuation a_{rel} and for the group delay ripple have to be reached at the frequencies given below also if the centre frequency f_o is shifted due to the temperature coefficient of frequency TC_f in the operating temperature range and due to a production tolerance for the centre frequency f_o .

D a t a		typ. value	Variation/ Limitation
Insertion loss (Reference level)	$a_e = a_{max}$	3 dB	max. 5 dB
Nominal frequency	f_N	-	456,49 MHz
Centre frequency	f_o	456,49 MHz	-
3 dB - bandwidth	BW	280 kHz	-
Usable signal bandwidth		-	min. $f_N \pm 10$ kHz
Relative attenuation $f_N + 910$ kHz $f_N \pm 0,7$ MHz ... $f_N \pm 10$ MHz	a_{rel}		min. 52 dB min. 40 dB
Temperature coefficient of frequency	TC_f	-0,036 ppm/K ²	-
Frequency inversion temperature		+ 25 °C	
Operating temperature range			- 10°C ... + 50°C

Generated: _____

Checked / approved: _____

VI TELEFILTER
 Potsdamer Straße 18
 D 14 513 TELTOW / Germany
 Tel: (+49) 3328 4784-52 / Fax: (+49) 3328 4784-30
 E-Mail: tft@telefilter.com

Vectron International, Inc.
 267 Lowell Road
 Hudson, NH 03051 / USA
 Tel: (603) 598-0070 Fax: (603) 598-0075
 E-Mail: vti@vtinh.com

VI TELEFILTER reserves the right to make changes to the product(s) and/or information contained herein without notice. No liability is assumed as a result of their use or application. No rights under any patent accompany the sale of any such product(s) or information.

VI TELEFILTER**Filter Specification****TFS 456 C 2/4****Construction and pin connection**

(All dimensions in mm)

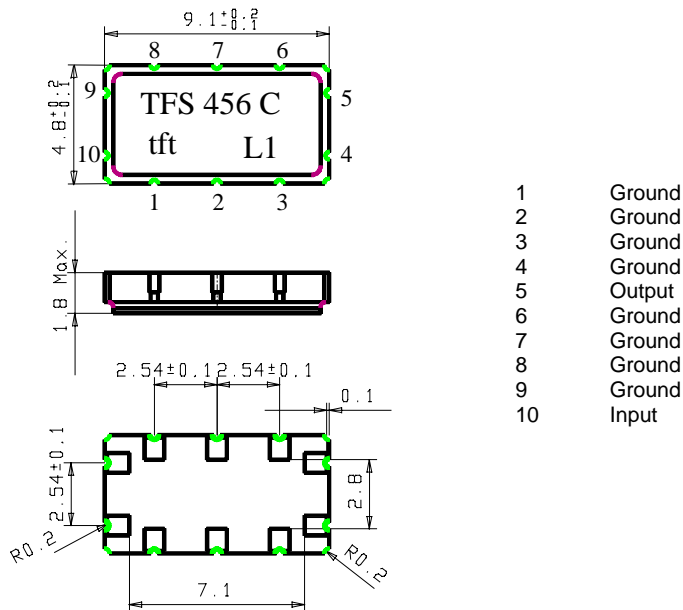
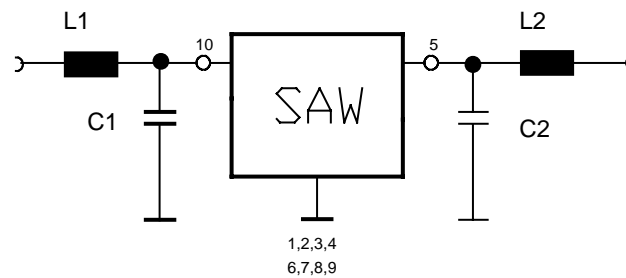
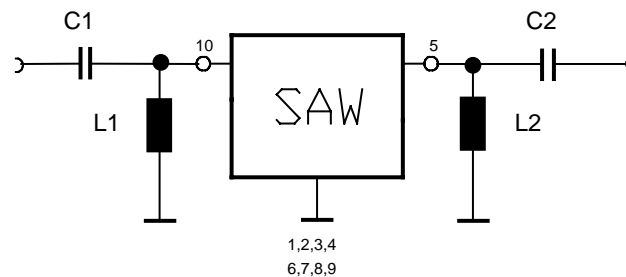
**50 Ω test circuit 1****50 Ω test circuit 2****Stability Characteristics**

After the following tests the filter shall meet the whole specification:

VI TELEFILTER
 Potsdamer Straße 18
 D 14 513 TELTOW / Germany
 Tel: (+49) 3328 4784-52 / Fax: (+49) 3328 4784-30
 E-Mail: tft@telefilter.com

Vectron International, Inc.
 267 Lowell Road
 Hudson, NH 03051 / USA
 Tel: (603) 598-0070 Fax: (603) 598-0075
 E-Mail: vti@vtinh.com

VI TELEFILTER reserves the right to make changes to the product(s) and/or information contained herein without notice. No liability is assumed as a result of their use or application. No rights under any patent accompany the sale of any such product(s) or information.

VI TELEFILTER**Filter Specification****TFS 456 C 3/4**

1. Shock: 100g, 18 ms, half sine wave, 3 shocks each plane;
DIN IEC 68 T2 - 27
2. Vibration: 10 Hz to 500 Hz, 0,075 mm or 1g respectively, 1 octave per min, 10 cycles per plan, 3 plans;
DIN IEC 68 T2 - 6
3. Damp heat: 90 % to 95 % rel. humidity, 40 °C, 10 days;
(steady state) DIN IEC 68 - 2 - 3
4. Resistance to solder heat (reflow): max. 2 times reflow process;
for temperature conditions refer to the attached "Air reflow temperature conditions" on sheet 4;

Packing

Tape & Reel: IEC 286 - 3, with exception of value for N and minimum bending radius;
tape type II, embossed carrier tape with top cover tape on the upper side;

max. pieces of filters per reel: 3000

Tape (all dimensions in mm)

W	: 16 ± 0,3
Po	: 4 ± 0,1
Do	: 1,5 + 0,5
D1	: 1,5 + 0,5
E	: 1,75 ± 0,1
F	: 7,5 ± 0,1
G (min)	: 0,75
P2	: 2 ± 0,05
P1	: 8 ± 0,1
D1(min)	: 1,5
Ao	: 5,3 ± 0,1
Bo	: 9,7 ± 0,1

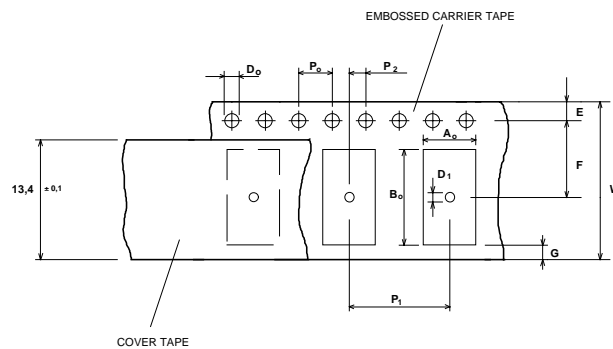
**Reel (all dimensions in mm):**

A	: 330
W1	: 16,4 +2
W2 (max)	: 22,4
N (min)	: ≥ 90
C	: 13 ± 0,25

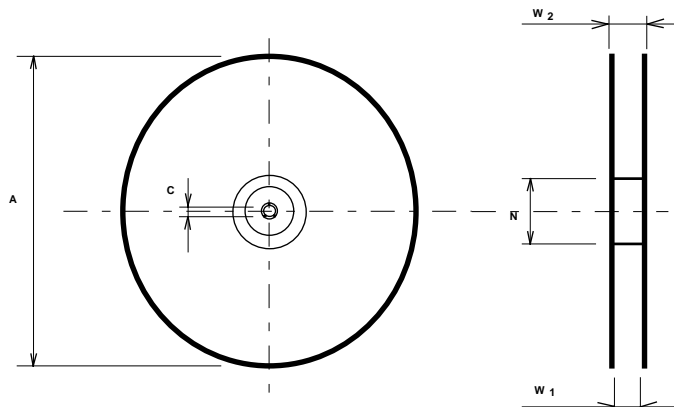

The minimum bending radius is 45 mm. The mounting surface of the filters faces the bottom side of the embossed carrier tape. The marking of the filters is able to read if the view is directed on the upper side of the carrier tape with the sprocket holes on the right side of the tape.

VI TELEFILTER
Potsdamer Straße 18
D 14 513 TELTOW / Germany
Tel: (+49) 3328 4784-52 / Fax: (+49) 3328 4784-30
E-Mail: tft@telefilter.com

Vectron International, Inc.
267 Lowell Road
Hudson, NH 03051 / USA
Tel: (603) 598-0070 Fax: (603) 598-0075
E-Mail: vti@vtinh.com

VI TELEFILTER reserves the right to make changes to the product(s) and/or information contained herein without notice. No liability is assumed as a result of their use or application. No rights under any patent accompany the sale of any such product(s) or information.

VI TELEFILTER**Filter Specification****TFS 456 C 4/4****Air reflow temperature conditions**

1st and 2nd air reflow profile

Name:	pre-heating periods	main-heating periods	peak temperature
Temperature:	150 °C - 170 °C	over 200 °C	255 °C ± 5 °C
Time:	60 sec. - 90 sec.	20 sec. - 25 sec.	

Chip-mount air reflow profile

Table for temperature vs. time during the air reflow process

Tolerance of temperatures: ± 5 °C

time / sec.	temperature / °C	time / sec.	temperature / °C
0	23	140	160
10	34	150	161
20	46	160	164
30	60	170	170
40	80	180	180
50	103	190	205
60	121	195	230
70	134	200	255
80	143	205	230
90	150	210	205
100	154	215	180
110	156	220	165
120	158	230	140
130	159	240	120

VI TELEFILTER
 Potsdamer Straße 18
 D 14 513 TELTOW / Germany
 Tel: (+49) 3328 4784-52 / Fax: (+49) 3328 4784-30
 E-Mail: tft@telefilter.com

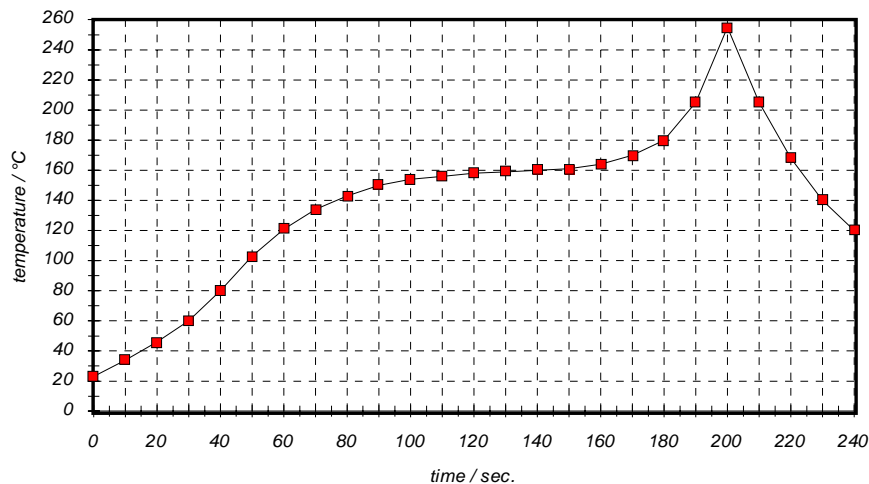
Vectron International, Inc.
 267 Lowell Road
 Hudson, NH 03051 / USA
 Tel: (603) 598-0070 Fax: (603) 598-0075
 E-Mail: vti@vtinh.com

VI TELEFILTER reserves the right to make changes to the product(s) and/or information contained herein without notice. No liability is assumed as a result of their use or application. No rights under any patent accompany the sale of any such product(s) or information.