

TLMA0110G 10 Gbits/s Limiting Amplifier

Features

- 31 dB gain, 37 dB differential
- Wideband response: 25 kHz to 10 GHz
- Complementary 50 Ω I/Os
- Adjustable threshold control
- Low power dissipation
- Single -5.0 V power supply
- 24-lead surface-mount package

Applications

- Data/clock main amplifier in SONET/SDH OC-192/STM-64 transmission systems and DWDM systems
- Digital video transmission
- SONET/SDH test equipment

Functional Description

Agere Systems Inc.'s TLMA0110G is a wideband limiting amplifier with differential inputs and outputs. It provides 31 dB of gain (37 dB differential) and 10 GHz of bandwidth in a 50 Ω environment. The TLMA0110G consists of a 50 Ω input buffer followed by three gain stages and a 50 Ω output buffer. The threshold level can be adjusted by inserting an external voltage or current source into the amplifier's positive or negative feedback loops. At input levels below 10 mVp-p (single-ended), the device acts as a linear amplifier. For input levels from 10 mVp-p up to 1 Vp-p, the device operates in its limiting mode, providing a constant typical output of 500 mVp-p (single-ended).

The TLMA0110G is designed for use in SONET OC-192 and SDH STM-64 receiver/regenerator applications. Amplifier operation is from a single -5.0 V power supply. The TLMA0110G is available as a die or in a 24-lead, hermetic, surface-mount package.

Functional Description (continued)

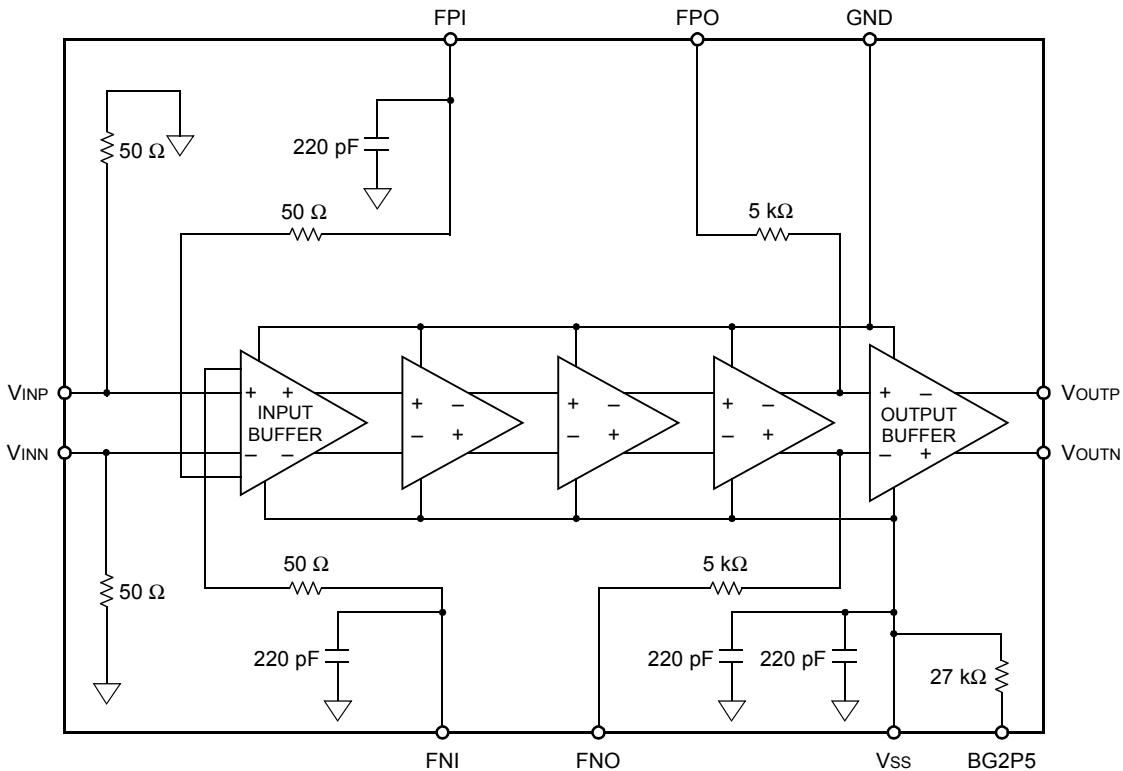

5-8197(F).a

Figure 1. Block Diagram

For additional information, contact your Agere Systems Account Manager or the following:

INTERNET: <http://www.agere.com>

E-MAIL: docmaster@micro.lucent.com

N. AMERICA: Agere Systems Inc., 555 Union Boulevard, Room 30L-15P-BA, Allentown, PA 18109-3286

1-800-372-2447, FAX 610-712-4106 (In CANADA: 1-800-553-2448, FAX 610-712-4106)

ASIA PACIFIC: Agere Systems Singapore Pte. Ltd., 77 Science Park Drive, #03-18 Cintech III, Singapore 118256

Tel. (65) 778 8833, FAX (65) 777 7495

CHINA: Agere Systems (Shanghai) Co., Ltd., 33/F Jin Mao Tower, 88 Century Boulevard Pudong, Shanghai 200121 PRC

Tel. (86) 21 50471212, FAX (86) 21 50472266

JAPAN: Agere Systems Japan Ltd., 7-18, Higashi-Gotanda 2-chome, Shinagawa-ku, Tokyo 141, Japan

Tel. (81) 3 5421 1600, FAX (81) 3 5421 1700

EUROPE: Data Requests: DATALINE: Tel. (44) 7000 582 368, FAX (44) 1189 328 148

Technical Inquiries: GERMANY: (49) 89 95086 0 (Munich), UNITED KINGDOM: (44) 1344 865 900 (Ascot),

FRANCE: (33) 1 40 83 68 00 (Paris), SWEDEN: (46) 8 594 607 00 (Stockholm), FINLAND: (358) 9 3507670 (Helsinki),

ITALY: (39) 02 6608131 (Milan), SPAIN: (34) 1 807 1441 (Madrid)

Agere Systems Inc. reserves the right to make changes to the product(s) or information contained herein without notice. No liability is assumed as a result of their use or application.