

VF494

8 Pin DIP VCXO HCMOS/TTL Compatible

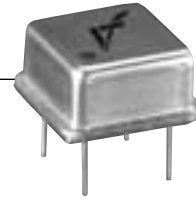

APPLICATIONS

Networking equipment, portable electronics, PLL applications, high speed video imaging

FEATURES

- Low Cost
- Standard Footprint
- Small Size

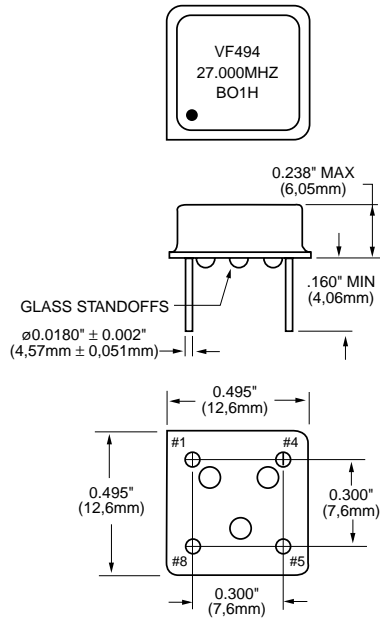

All dimensions are typical unless otherwise specified.

Creating a Part Number

VF494 - [] - [] - **[FREQ.]**

INPUT VOLTAGE	
Code	Specification
L	3.3 Volt ±5%
	5.0 Volt ±5% (std.)

ABSOLUTE PULL RANGE (ppm)	
Code	Specification
	±50 ppm MIN. (std.)
XXX	up to 200 ppm MAX. (customer specified)

LEAD CONFIGURATION	
Code	Specification
GR	Gull Wing
G	Gull Wing
	Through Hole (std.)

Example: VF494L-G-XXX-27MHz: Input Voltage 3.3 Volt ±5%, Lead Configuration Gull Wing, Absolute Pull Range up to 200 ppm max.

Parameter	Symb	Condition	Min	Typ	Max	Unit	Note	
Absolute Max. Ratings	Input Break Down Voltage	V _{cc}	-0.5		7.0	V		
	Storage Temp.	T _s	-40		+85	°C		
	Control Voltage	V _c	-1		9	V		
Electrical	Frequency Range	F	1.0		50	MHz		
	Frequency Stability	ΔF/F	vs. Temp., V _{cc}			±25	ppm	
	Input Voltage	V _{cc}		4.75 3.15	5.00 3.30	5.25 3.45	V	Std. LV Opt.
	Input Current	I _{cc}	Max load		35		mA	@20MHz
	Load	10 TTL gates or 15pF MAX						
	Duty Cycle		@0.5V _{cc}	40	50	60	%	
	Rise/Fall Time	Tr/Tf				8	ns	
	Logic "1" Level	V _{oh}	Loaded	0.9V _{cc}				
	Logic "0" Level	V _{ol}	Loaded			0.1V _{cc}		
	Start-up Time	T _s			2	10	ms	
	Phase Jitter		1σ, F<45MHz			1	ps	fj>1KHz
	Modulation BW		@V _c = 2.5V	10			KHz	@-3db
	Input Impedance		f<10KHz	50			KOhm	
	Control Voltage	V _c	V _{cc} = 5V V _{cc} = 3.3V	0.0 0.0	2.50 1.65	5.00 3.30	V	
	Deviation Slope		Monotonic, positive		50 100		ppm/V	V _{cc} = 5.00 V _{cc} = 3.30
Linearity					±15	%		
Pullability					±100	ppm		
Setability (V _c for center freq)	V _{c0}	@25°C, F _{nom} .	2.00 1.25	2.50 1.65	3.00 2.05	V	V _{cc} = 5.0V V _{cc} = 3.3V	
Operating Temperature Range		0°C to +70°C						
Mechanical Shock		Per MIL-STD-202, Method 213, Cond. E						
Thermal Shock		Per MIL-STD-883, Method 1011, Cond. A						
Vibration		Per MIL-STD-883, Method 2007, Cond. A						
Soldering Conditions		260°C, for 10s, Max.						
Hermetic Seal		Leak rate less than 5 x 10 ⁻⁸ atm.cc/s of helium						
Pin Out		Pin #1-Voltage Control Pin #5-Output		Pin #4-Ground, Case Pin #8-V _{cc}				

Environmental and Mechanical
Electrical Connections

All specifications are subject to change without notice.