

FEATURES

- LOWER ESR - HIGH Q at HIGH FREQUENCY
- STABLE NPO CHARACTERISTICS OVER TIME, TEMPERATURE AND VOLTAGE
- EIA 0402 AND 0603 CASE SIZES
- IDEAL FOR WIRELESS DATA AND VOICE COMMUNICATIONS APPLICATIONS
WLANs, HIPERLAN, 802.11A, 802.11B, Wi-Fi, BLUETOOTH, TELEMATICS, PCS, LMDS AND CELLULAR

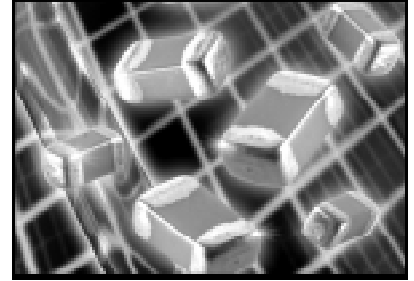

SPECIFICATIONS	NPO
Operating Temperature Range	-55°C to +125°C
Temperature Characteristic	0 ± 30PPM/°C
Dissipation Factor	0.001 max. (1MHz, +25°C)
Insulation Resistance@WVDC	10,000 Megohms min. @ +25°C
Capacitance Range	0.4pF ~ 22pF (1MHz, 1.0Vrms±0.2, +25°C)
Capacitance Tolerances	±0.05pF(A), ±0.075 (X), ±0.1pF(B), ±0.25pF(C), ±0.5pF(D) ±1%(F), ±2%(G), ±5%(J)
Rated Voltage	25, 50VDC
Dielectric Withstanding Voltage	125VDC for 5 ± 1 seconds

DIMENSIONS (mm)

EIA Case Size	0402	0603
Length (L)	1.0 ±0.05	1.6 ±0.15
Width (W)	0.5 ±0.05	0.8 ±0.15
Thickness (T)	0.6 max.	1.0 max.
Termination Width (P)	0.10 ~ 0.30	.25 ~.60

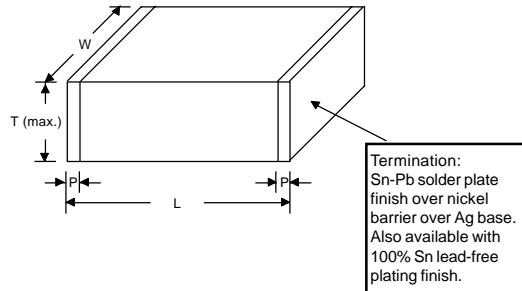

PART NUMBERING SYSTEM

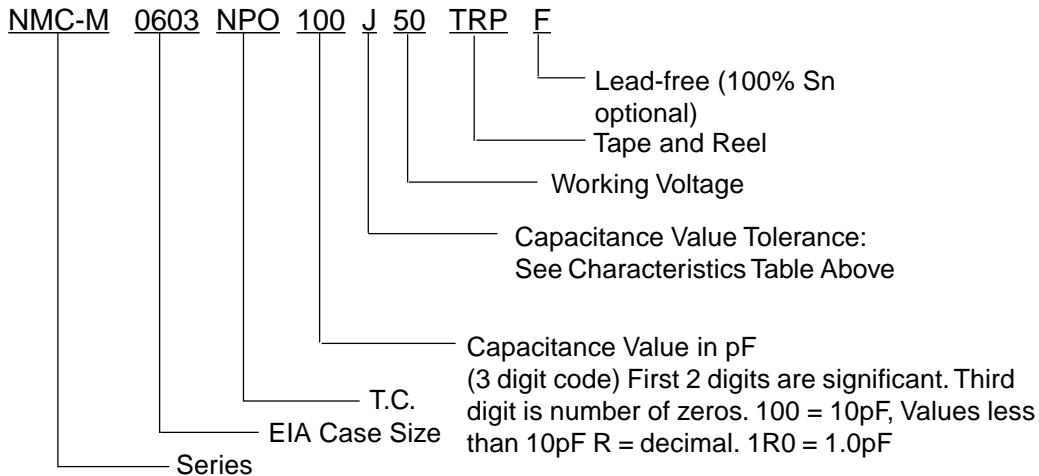

STANDARD VALUES AND CHARACTERISTICS

NIC PART NUMBER	CAPACITANCE VALUE (pF)	AVAILABLE TOLERANCE	Q FACTOR (MIN. @ 1GHz)	ESR Ω (@ 1GHz)*
NMC-M0402NPO0R1A25TRP	0.1	A	500	3.183
NMC-M0402NPO0R2A25TRP	0.2	A	500	1.592
NMC-M0402NPO0R3A25TRP	0.3	A	500	1.061
NMC-M0402NPO0R4A25TRP	0.4	A	500	0.796
NMC-M0402NPO0R5A25TRP	0.5	A	500	0.637
NMC-M0402NPO0R6X25TRP	0.6	X	500	0.531
NMC-M0402NPO0R7X25TRP	0.7	X	500	0.455
NMC-M0402NPO0R8X25TRP	0.8	X	500	0.398
NMC-M0402NPO0R9X25TRP	0.9	X	500	0.354
NMC-M0402NPO1R0B25TRP	1.0	B	350	0.455
NMC-M0402NPO1R1B25TRP	1.1	B	350	0.413
NMC-M0402NPO1R2B25TRP	1.2	B	350	0.379
NMC-M0402NPO1R3B25TRP	1.3	B	350	0.350
NMC-M0402NPO1R5B25TRP	1.5	B	350	0.303
NMC-M0402NPO1R6B25TRP	1.6	B	350	0.284
NMC-M0402NPO1R8B25TRP	1.8	B	350	0.253
NMC-M0402NPO2R0B25TRP	2.0	B	250	0.318
NMC-M0402NPO2R2B25TRP	2.2	B	250	0.289
NMC-M0402NPO2R4B25TRP	2.4	B	250	0.265
NMC-M0402NPO2R7B25TRP	2.7	B	250	0.236
NMC-M0402NPO3R0B25TRP	3.0	B	250	0.212
NMC-M0402NPO3R3C25TRP	3.3	C	200	0.241
NMC-M0402NPO3R9C25TRP	3.9	C	180	0.227
NMC-M0402NPO4R7C25TRP	4.7	C	150	0.226
NMC-M0402NPO5R6C25TRP	5.6	C	120	0.237
NMC-M0402NPO6R8C25TRP	6.8	C	100	0.234
NMC-M0402NPO8R2C25TRP	8.2	C	80	0.243
NMC-M0402NPO100C25TRP	10	C	80	0.199
NMC-M0402NPO120J25TRP	12	J	60	0.211
NMC-M0402NPO150J25TRP	15	J	40	0.265

* Typical ESR

For Quality Factor (Q)
over Frequency (F) curves
see www.niccomp.com

STANDARD VALUES AND CHARACTERISTICS

NIC PART NUMBER	CAPACITANCE VALUE (pF)	AVAILABLE TOLERANCE	Q FACTOR (MIN. @ 1GHz)	ESR Ω (@ 1GHz)*
NMC-M0603NPO0R4x50TRP	0.4	A , B	300	1.326
NMC-M0603NPO0R5x50TRP	0.5	A, B	300	1.061
NMC-M0603NPO0R6x50TRP	0.6	A , B	300	0.884
NMC-M0603NPO0R7x50TRP	0.7	A, B	300	0.757
NMC-M0603NPO0R8x50TRP	0.8	A, B	300	0.663
NMC-M0603NPO0R9x50TRP	0.9	A , B	300	0.589
NMC-M0603NPO1R0x50TRP	1.0	A , B	300	0.530
NMC-M0603NPO1R1x50TRP	1.1	A, B	300	0.482
NMC-M0603NPO1R2x50TRP	1.2	A , B	250	0.530
NMC-M0603NPO1R5x50TRP	1.5	A, B	250	0.424
NMC-M0603NPO1R8x50TRP	1.8	A, B	200	0.442
NMC-M0603NPO2R0x50TRP	2.0	A , B	200	0.397
NMC-M0603NPO2R2x50TRP	2.2	B, C	100	0.723
NMC-M0603NPO2R4x50TRP	2.4	B, C	100	0.663
NMC-M0603NPO2R7x50TRP	2.7	B, C	100	0.589
NMC-M0603NPO3R0x50TRP	3.0	B, C	100	0.530
NMC-M0603NPO3R3x50TRP	3.3	B, C	100	0.482
NMC-M0603NPO3R6x50TRP	3.6	B, C	100	0.442
NMC-M0603NPO3R9x50TRP	3.9	B, C	100	0.408
NMC-M0603NPO4R3x50TRP	4.3	B, C	100	0.370
NMC-M0603NPO4R7x50TRP	4.7	B, C	100	0.338
NMC-M0603NPO5R1x50TRP	5.1	C, D	80	0.390
NMC-M0603NPO5R6x50TRP	5.6	C, D	80	0.355
NMC-M0603NPO6R2x50TRP	6.2	C, D	80	0.320
NMC-M0603NPO6R8x50TRP	6.8	C,D	80	0.292
NMC-M0603NPO7R5x50TRP	7.5	C, D	80	0.265
NMC-M0603NPO8R2x50TRP	8.2	C, D	80	0.242
NMC-M0603NPO9R1x50TRP	9.1	C, D	80	0.218
NMC-M0603NPO100x50TRP	10	F, G, J	80	0.198
NMC-M0603NPO120x50TRP	12	F, G, J	70	0.189
NMC-M0603NPO150x50TRP	15	F, G, J	60	0.176
NMC-M0603NPO180x50TRP	18	F, G, J	50	0.176
NMC-M0603NPO200x50TRP	20	F, G, J	30	0.265
NMC-M0603NPO220x50TRP	22	F, G, J	30	0.241

*Typical ESR

For Quality Factor (Q)
over Frequency (F) curves
see www.niccomp.com