

features

- 5-Pin SC-70 (SOT-323) Package
- Supply Current of 9 μ A (Typ)
- Power-On Reset Generator With Fixed Delay Time
 - TPS3800 = 100 ms
 - TPS3801 = 200 ms
 - TPS3802 = 400 ms
- Precision Supply Voltage Monitor 1.8 V, 2.5 V, 2.7 V, 3 V, 3.3 V, 5 V, and Adjustable
- Manual Reset Input (Except TPS3801–01)
- Temperature Range . . . -40°C to 85°C

description

The TPS380x family of supervisory circuits provide circuit initialization and timing supervision, primarily for DSPs and processor-based systems.

During power-on, $\overline{\text{RESET}}$ is asserted when the supply voltage V_{DD} becomes higher than 1.1 V. Thereafter, the supervisory circuit monitors V_{DD} (or SENSE) and keeps $\overline{\text{RESET}}$ active as long as V_{DD} (or SENSE) remains below the threshold voltage (V_{IT}). An internal timer delays the return of the output to the inactive state (high) to ensure proper system reset. The delay time (t_d) starts after V_{DD} (or SENSE) has risen above the threshold voltage (V_{IT}). When the supply voltage drops below the threshold voltage (V_{IT}) the output becomes active (low) again. No external components are required. All the devices of this family have a fixed sense-threshold voltage (V_{IT}) set by an internal voltage divider, except for the TPS3801–01, which can be customized with two external resistors at the SENSE input.

The TPS380x devices, except the TPS3801–01, incorporate a manual reset input ($\overline{\text{MR}}$). A low level at $\overline{\text{MR}}$ causes $\overline{\text{RESET}}$ to become active.

The product spectrum is designed for supply voltages of 1.8 V, 2.5 V, 2.7 V, 3 V, 3.3 V, and 5 V. The circuits are available in a 5-pin SC-70 (SOT-323) package, which is only about half the size of a 5-pin SOT-23 package.

The TPS3801–01 can monitor voltages as low as 1.14 V, depending on the configuration of the external resistor divider.

The TPS380x devices are characterized for operation over a temperature range of -40°C to 85°C .

applications

- Applications Using DSPs, Microcontrollers, or Microprocessors
- Wireless Communication Systems
- Portable/Battery-Powered Equipment
- Programmable Controls
- Intelligent Instruments
- Industrial Equipment
- Notebook/Desktop Computers
- Automotive Systems

TPS380x . . . DCK PACKAGE
(TOP VIEW)

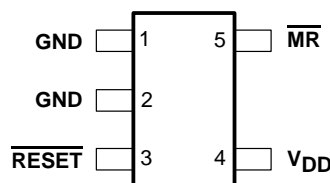

TPS3801–01 . . . DCK PACKAGE
(TOP VIEW)

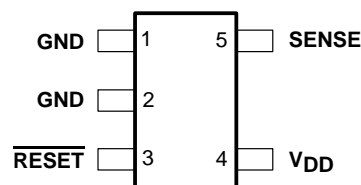

typical applications

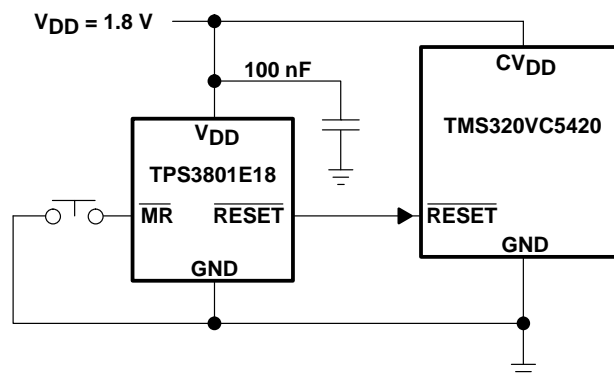

Please be aware that an important notice concerning availability, standard warranty, and use in critical applications of Texas Instruments semiconductor products and disclaimers thereto appears at the end of this data sheet.

PRODUCTION DATA information is current as of publication date. Products conform to specifications per the terms of Texas Instruments standard warranty. Production processing does not necessarily include testing of all parameters.

**TEXAS
INSTRUMENTS**

POST OFFICE BOX 655303 • DALLAS, TEXAS 75265

Copyright © 2002, Texas Instruments Incorporated

TPS3800-xx, TPS3801-xx, TPS3802-xx ULTRA-SMALL SUPPLY VOLTAGE SUPERVISORS

SLVS219B – AUGUST 1999 – REVISED APRIL 2002

AVAILABLE OPTIONS

T _A	DEVICE NAME	THRESHOLD VOLTAGE	TYP DELAY TIME	MARKING
-40°C to 85°C	TPS3801-01DCK	1.14 V	200 ms	ARF
	TPS3801E18DCK	1.71 V	200 ms	ARE
	TPS3801J25DCK	2.25 V	200 ms	NJA
	TPS3800G27DCK	2.5 V	95 ms	ARI
	TPS3801L30DCK	2.64 V	200 ms	NPA
	TPS3801K33DCK	2.93 V	200 ms	NWA
	TPS3802L30DCK	2.64 V	380 ms	ASA
	TPS3802K33DCK	2.93 V	380 ms	ARK
	TPS3801T50DCK	4 V	25 ms	AVI
	TPS3801I50DCK	4.55 V	200 ms	NSA

FUNCTION/TRUTH TABLE, TPS380x

$\overline{\text{MR}}$	V _{DD} >V _{IT}	RESET
L	0	L
L	1	L
H	0	L
H	1	H

ORDERING INFORMATION

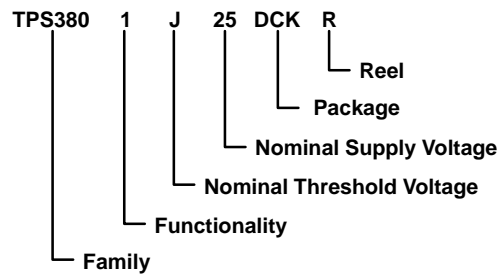

functional block diagram

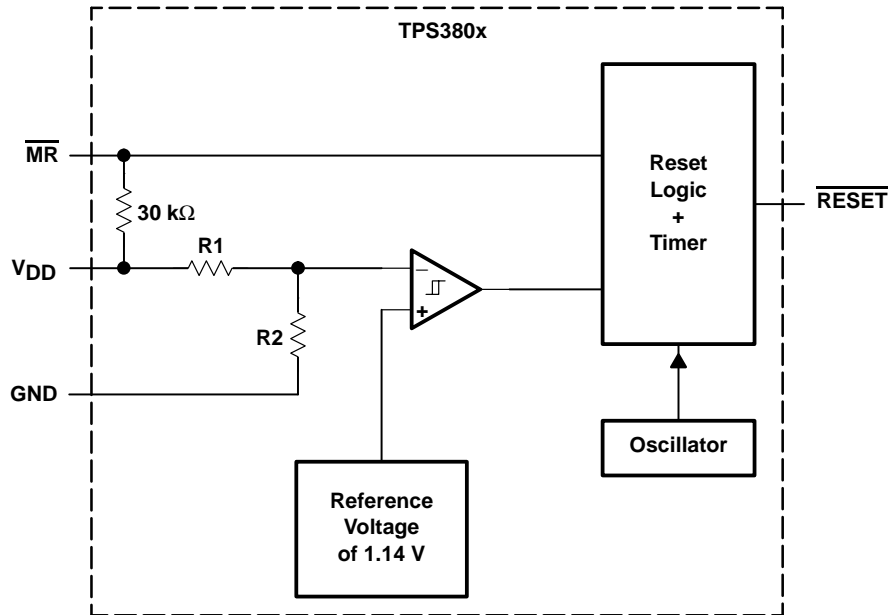

functional block diagram (continued)

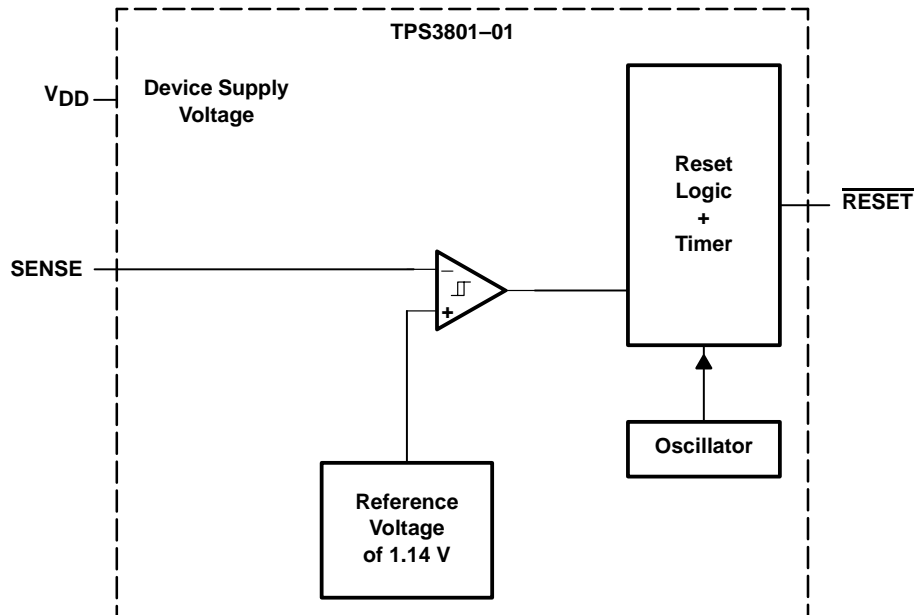

timing diagram

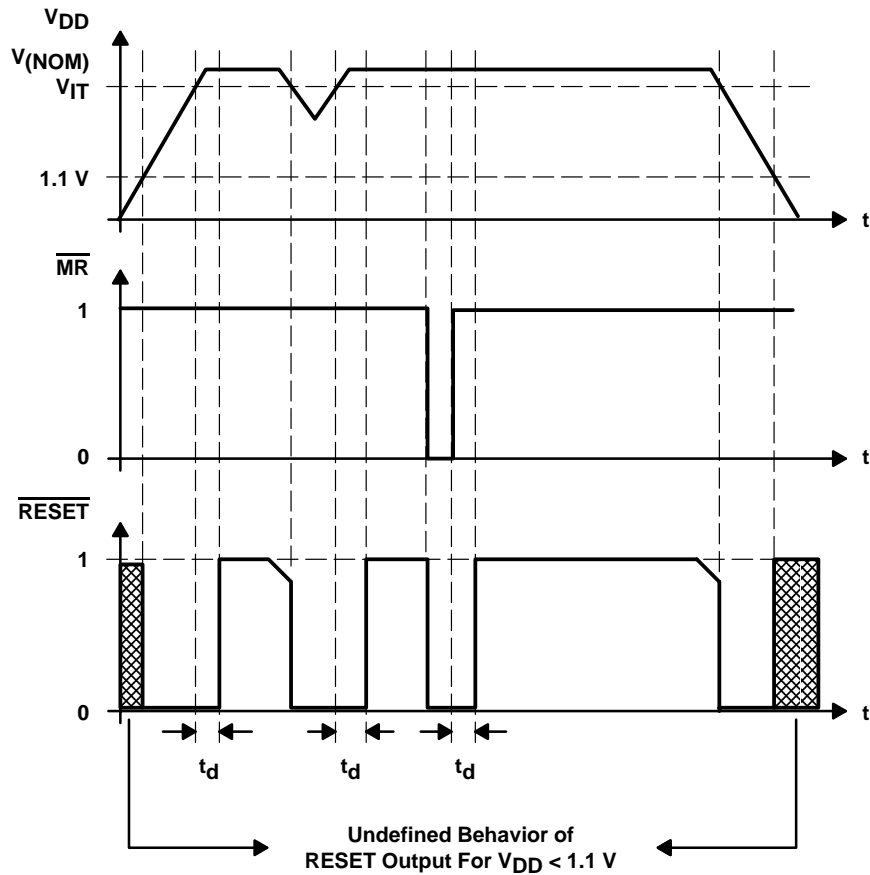

NOTE: $\overline{\text{RESET}}$ should not be forced high during the power-up sequence (until $V_{\text{DD}} > 1.1 \text{ V}$).

TPS3800-xx, TPS3801-xx, TPS3802-xx ULTRA-SMALL SUPPLY VOLTAGE SUPERVISORS

SLVS219B – AUGUST 1999 – REVISED APRIL 2002

absolute maximum ratings over operating free-air temperature (unless otherwise noted)†

Supply voltage, V_{DD} (see Note1)	7 V
All other pins (see Note 1)	-0.3 V to 7 V
Maximum low-output current, I_{OL}	5 mA
Maximum high-output current, I_{OH}	-5 mA
Input-clamp current, I_{IK} ($V_I < 0$ or $V_I > V_{DD}$)	± 20 mA
Output-clamp current, I_{OK} ($V_O < 0$ or $V_O > V_{DD}$)	± 20 mA
Continuous total power dissipation	See Dissipation Rating Table
Operating free-air temperature range, T_A	-40°C to 85°C
Storage temperature range, T_{stg}	-65°C to 150°C
Soldering temperature	260°C

† Stresses beyond those listed under “absolute maximum ratings” may cause permanent damage to the device. These are stress ratings only, and functional operation of the device at these or any other conditions beyond those indicated under “recommended operating conditions” is not implied. Exposure to absolute-maximum-rated conditions for extended periods may affect device reliability.

NOTE 1: All voltage values are with respect to GND. For reliable operation, the device should not be operated at 7 V for more than $t=1000h$ continuously.

DISSIPATION RATING TABLE

PACKAGE	$T_A < 25^\circ\text{C}$ POWER RATING	DERATING FACTOR ABOVE $T_A = 25^\circ\text{C}$	$T_A = 70^\circ\text{C}$ POWER RATING	$T_A = 85^\circ\text{C}$ POWER RATING
DCK	321 mW	2.6 mW/°C	206 mW	167 mW

recommended operating conditions at specified temperature range

		MIN	MAX	UNIT
Supply voltage, V_{DD}	TPS3801J25, TPS3801L30, TPS3801K33, TPS3801I50, TPS3801T50	2	6	V
	All other devices	1.6	4	
Input voltage, V_I		0	$V_{DD}+0.3$	V
High-level input voltage, V_{IH}		$0.7 \times V_{DD}$		V
Low-level input voltage, V_{IL}			$0.3 \times V_{DD}$	V
Input transition rise and fall rate at \overline{MR} , $\Delta t/\Delta V$			100	ns/V
Operating free-air temperature range, T_A		-40	85	°C



TPS3800-xx, TPS3801-xx, TPS3802-xx ULTRA-SMALL SUPPLY VOLTAGE SUPERVISORS

SLVS219B – AUGUST 1999 – REVISED APRIL 2002

electrical characteristics over recommended operating free-air temperature range (unless otherwise noted)

PARAMETER		TEST CONDITIONS	MIN	TYP	MAX	UNIT		
V _{OH}	High-level output voltage	V _{DD} = 1.6 V to 6 V, I _{OH} = -500 μA	V _{DD} - 0.2			V		
		V _{DD} = 3.3 V, I _{OH} = -2 mA	V _{DD} - 0.4					
		V _{DD} = 6 V, I _{OH} = -4 mA (see Note 4)	V _{DD} - 0.4					
V _{OL}	Low-level output voltage	V _{DD} = 1.6 V to 6 V, I _{OL} = 500 μA	0.2			V		
		V _{DD} = 3.3 V, I _{OL} = 2 mA	0.4					
		V _{DD} = 6 V, I _{OL} = 4 mA (see Note 4)	0.4					
Power-up reset voltage (see Note 2)		V _{DD} ≥ 1.1 V, I _{OL} = 50 μA	0.2			V		
V _{IT-}	Negative-going input threshold voltage (see Note 3)	T _A = -40°C to 85°C	TPS380x-01	1.117	1.14	1.163	V	
			TPS380xE18	1.67	1.71	1.75		
			TPS380xJ25	2.2	2.25	2.3		
			TPS380xG27	2.45	2.5	2.55		
			TPS380xL30	2.58	2.64	2.7		
			TPS380xK33	2.87	2.93	2.99		
			TPS380xI50	4.45	4.55	4.65		
			TPS380xT50	3.92	4	4.08		
V _{hys}	Hysteresis	TPS380x-01	15			mV		
		TPS380xx18	25					
		TPS380xx25	30					
		TPS380xx27	35					
		TPS380xx30	35					
		TPS380xx33	40					
		TPS380xx50	60					
I _{IH}	High-level input current	\overline{MR}	MR = 0.7 × V _{DD} , V _{DD} = 6 V		-40	-60	-100	μA
I _{IL}	Low-level input current		MR = 0 V, V _{DD} = 6 V		-130	-200	-340	
I _I	Input current	SENSE			-25	25		nA
I _{DD}	Supply current	TPS3801J25, TPS3801L30, TPS3801K33, TPS3801I50, TPS3801T50	V _{DD} = 2 V, \overline{MR} and output unconnected	9		12	μA	
			V _{DD} = 6 V, \overline{MR} and output unconnected	20		25		
		TPS3801-01	V _{DD} = 1.6 V, SENSE = 0 V to V _{DD} , output unconnected	7		10		
			V _{DD} = 4 V, SENSE = 0 V to V _{DD} , output unconnected	9		12		
		TPS3801E18, TPS3800G27, TPS3802K33, TPS3802L30	V _{DD} = 1.6 V, \overline{MR} and output unconnected	8		11		
	V _{DD} = 4 V, \overline{MR} and output unconnected	13		18				
C _i	Input capacitance	V _I = 0 V to V _{DD}	5		pF			

- NOTES: 2. The lowest supply voltage at which RESET becomes active. t_r, V_{DD} ≥ 15 μs/V.
3. To ensure the best stability of the threshold voltage, a bypass capacitor (0.1-μF ceramic) should be placed near the supply terminals.
4. Only valid for the TPS3801J25, TPS3801L30, TPS3801K33, TPS3801I50, and TPS3801T50.



TPS3800-xx, TPS3801-xx, TPS3802-xx ULTRA-SMALL SUPPLY VOLTAGE SUPERVISORS

SLVS219B – AUGUST 1999 – REVISED APRIL 2002

timing requirements at $R_L = 1\text{ M}\Omega$, $C_L = 50\text{ pF}$, $T_A = 25^\circ\text{C}$

PARAMETER		TEST CONDITIONS	MIN	TYP	MAX	UNIT
t_w	Pulse width	at SENSE	$V_{DD} = 1.6\text{ V}$, $V_{IH} = 1.1 \times V_{IT-}$, $V_{IL} = 0.9 \times V_{IT-}$	1		μs
		at $\overline{V_{DD}}$	$V_{DD} = V_{IT-} + 0.2\text{ V}$, $V_{DD} = V_{IT-} - 0.2\text{ V}$	3		
		at \overline{MR}	$V_{DD} \geq V_{IT-} + 0.2\text{ V}$, $V_{IL} = 0.3 \times V_{DD}$, $V_{IH} = 0.7 \times V_{DD}$	100		ns

switching characteristics at $R_L = 1\text{ M}\Omega$, $C_L = 50\text{ pF}$, $T_A = 25^\circ\text{C}$

PARAMETER		TEST CONDITIONS	MIN	TYP	MAX	UNIT	
t_d	Delay time	$V_{DD} \geq V_{IT-} + 0.2\text{ V}$, $\overline{MR} \geq 0.7 \times V_{DD}$ See timing diagram	TPS3801T50	15	25	35	ms
			TPS3800	60	95	140	
			TPS3801	120	200	280	
			TPS3802	240	380	560	
t_{PHL}	Propagation (delay) time, high-to-low-level output	\overline{MR} to $\overline{\text{RESET}}$ delay	$V_{DD} \geq V_{IT-} + 0.2\text{ V}$, $V_{IL} = 0.3 \times V_{DD}$, $V_{IH} = 0.7 \times V_{DD}$	15		ns	
		$\overline{V_{DD}}$ to $\overline{\text{RESET}}$ delay	$V_{IL} = V_{IT-} - 0.2\text{ V}$, $V_{IH} = V_{IT-} + 0.2\text{ V}$	1		μs	
		SENSE to $\overline{\text{RESET}}$	$V_{IH} = V_{IT-} + 0.2\text{ V}$				

TYPICAL CHARACTERISTICS

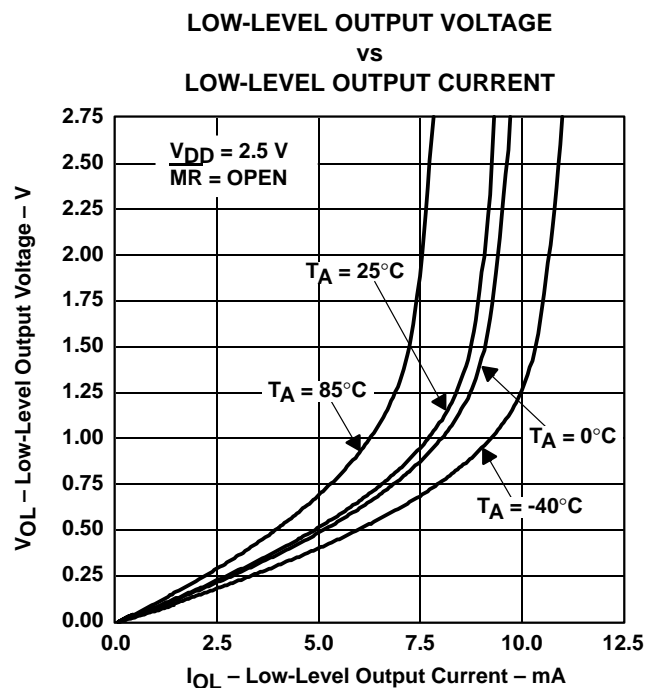

Figure 1

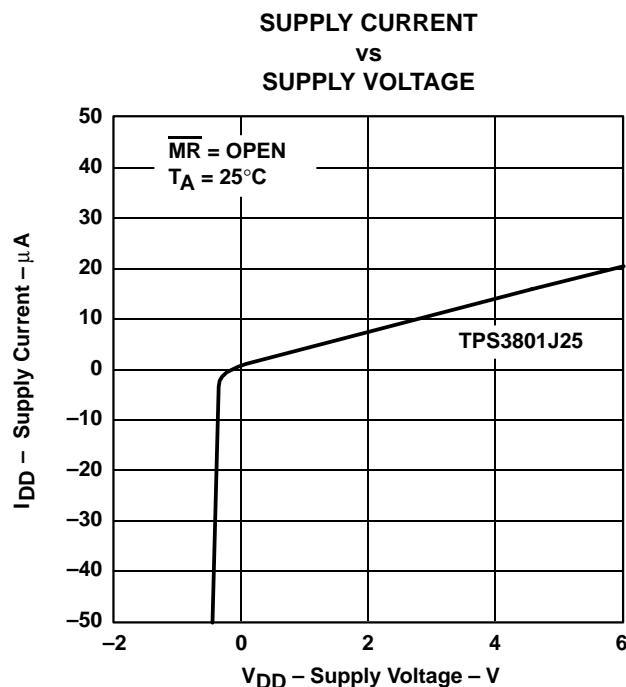

Figure 2

TYPICAL CHARACTERISTICS

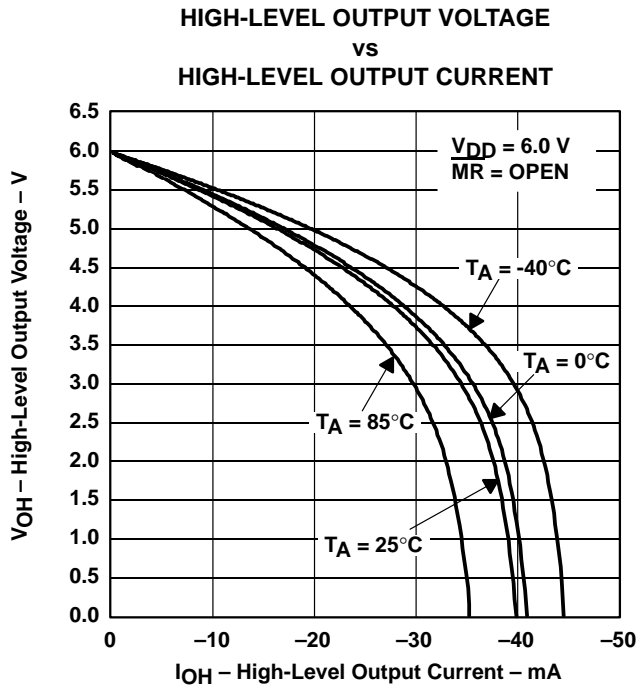

Figure 3

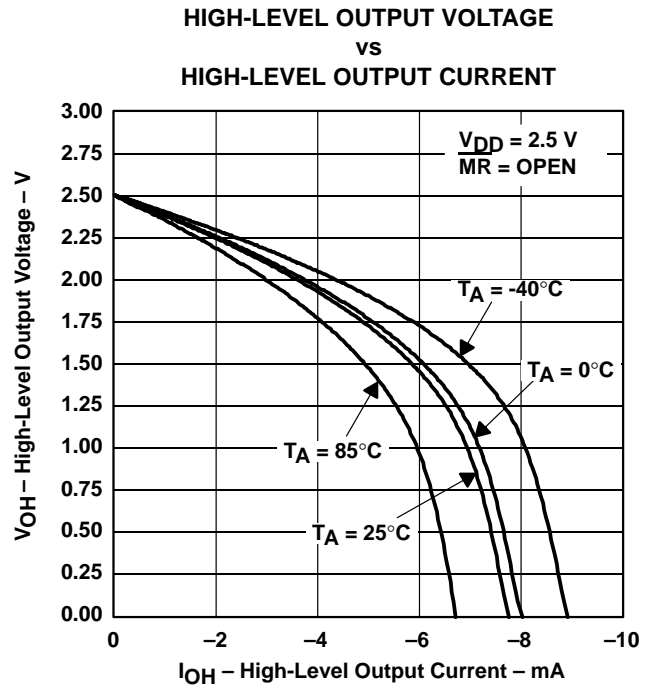

Figure 4

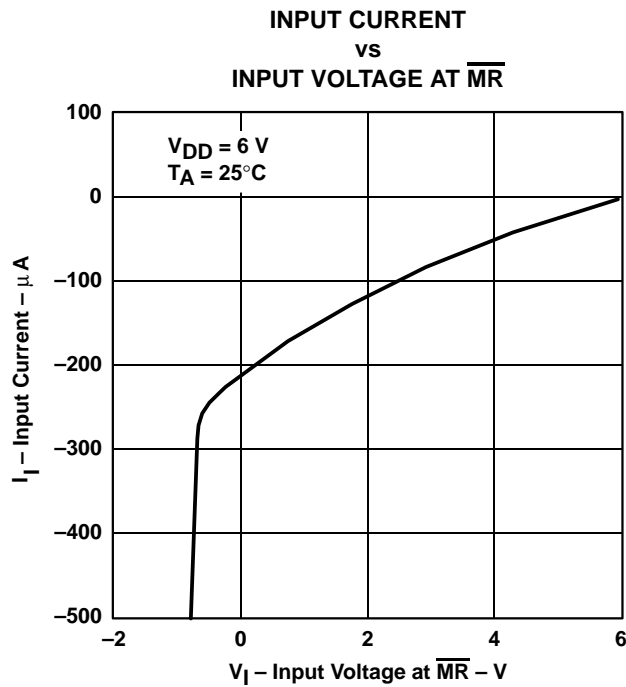

Figure 5

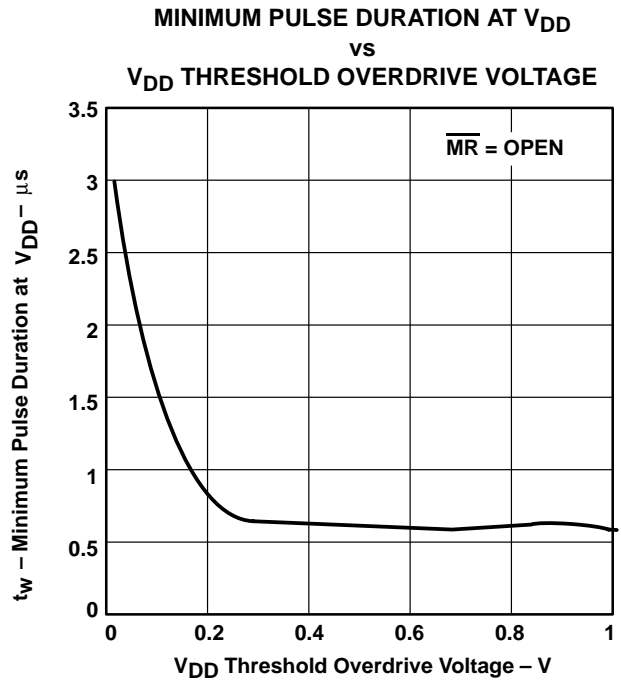
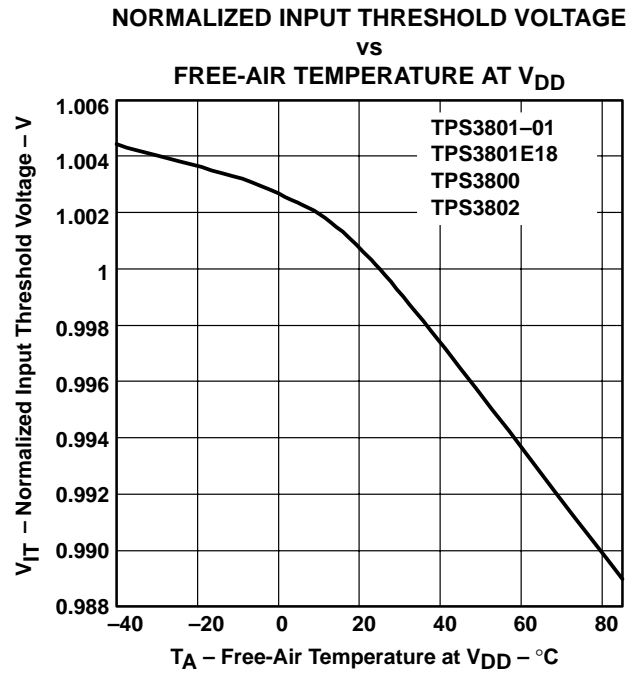
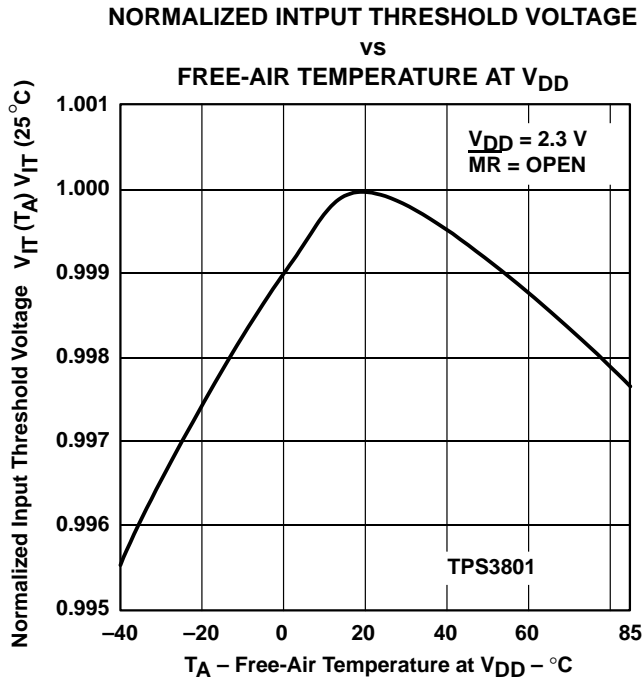

Figure 6

TPS3800-xx, TPS3801-xx, TPS3802-xx ULTRA-SMALL SUPPLY VOLTAGE SUPERVISORS

SLVS219B – AUGUST 1999 – REVISED APRIL 2002

TYPICAL CHARACTERISTICS



MECHANICAL DATA

DCK (R-PDSO-G5)

PLASTIC SMALL-OUTLINE PACKAGE

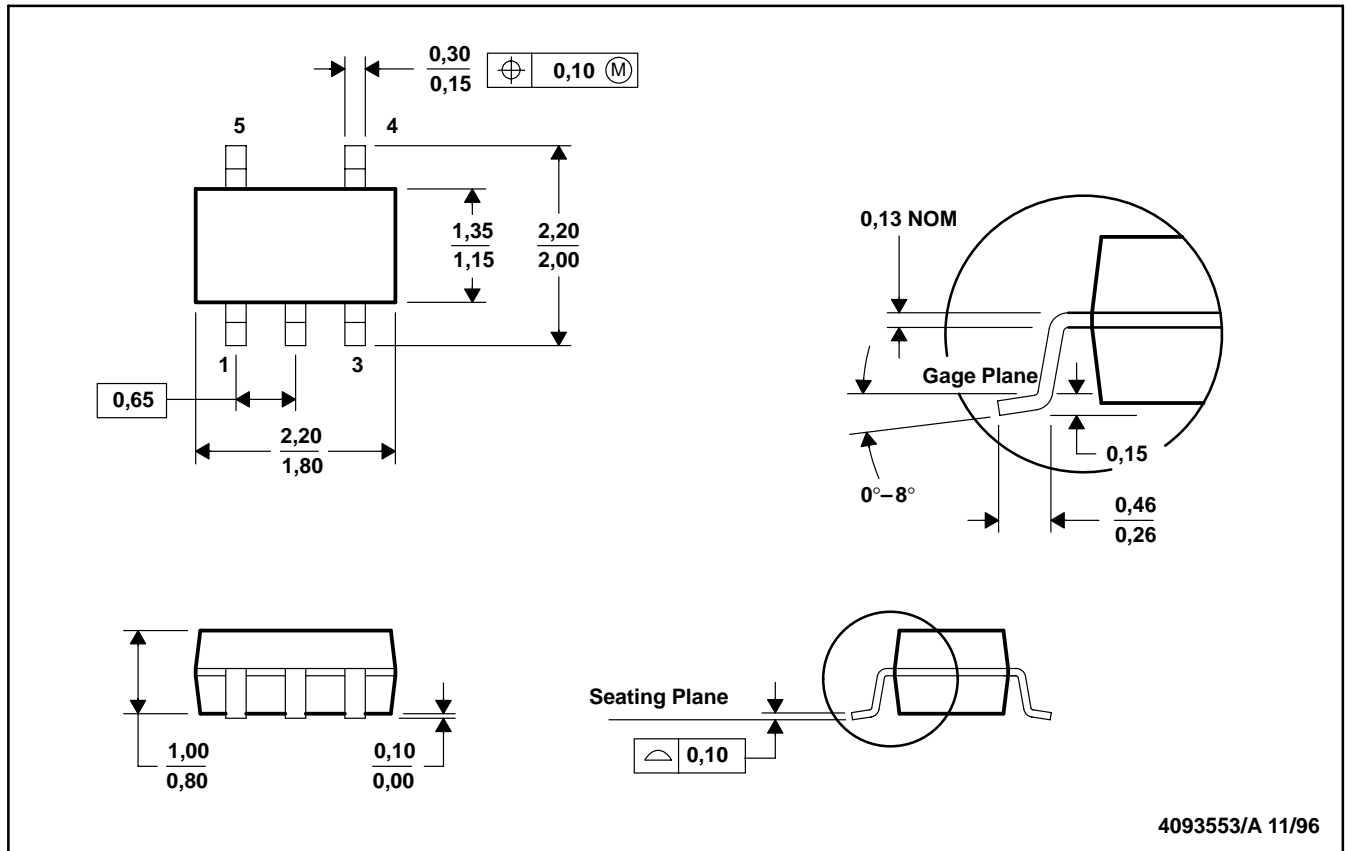

- NOTES: A. All linear dimensions are in millimeters.
 B. This drawing is subject to change without notice.
 C. Body dimensions include mold flash or protrusion.

IMPORTANT NOTICE

Texas Instruments Incorporated and its subsidiaries (TI) reserve the right to make corrections, modifications, enhancements, improvements, and other changes to its products and services at any time and to discontinue any product or service without notice. Customers should obtain the latest relevant information before placing orders and should verify that such information is current and complete. All products are sold subject to TI's terms and conditions of sale supplied at the time of order acknowledgment.

TI warrants performance of its hardware products to the specifications applicable at the time of sale in accordance with TI's standard warranty. Testing and other quality control techniques are used to the extent TI deems necessary to support this warranty. Except where mandated by government requirements, testing of all parameters of each product is not necessarily performed.

TI assumes no liability for applications assistance or customer product design. Customers are responsible for their products and applications using TI components. To minimize the risks associated with customer products and applications, customers should provide adequate design and operating safeguards.

TI does not warrant or represent that any license, either express or implied, is granted under any TI patent right, copyright, mask work right, or other TI intellectual property right relating to any combination, machine, or process in which TI products or services are used. Information published by TI regarding third-party products or services does not constitute a license from TI to use such products or services or a warranty or endorsement thereof. Use of such information may require a license from a third party under the patents or other intellectual property of the third party, or a license from TI under the patents or other intellectual property of TI.

Reproduction of information in TI data books or data sheets is permissible only if reproduction is without alteration and is accompanied by all associated warranties, conditions, limitations, and notices. Reproduction of this information with alteration is an unfair and deceptive business practice. TI is not responsible or liable for such altered documentation.

Resale of TI products or services with statements different from or beyond the parameters stated by TI for that product or service voids all express and any implied warranties for the associated TI product or service and is an unfair and deceptive business practice. TI is not responsible or liable for any such statements.

Mailing Address:

Texas Instruments
Post Office Box 655303
Dallas, Texas 75265