

MOS INTEGRATED CIRCUIT

μ PD78011H(A), 78012H(A), 78013H(A), 78014H(A)

8-BIT SINGLE-CHIP MICROCONTROLLER

DESCRIPTION

Compared to the μ PD78011H, 78012H, 78013H, and 78014H (standard models), the μ PD78011H(A), 78012H(A), 78013H(A), and 78014H(A) employ a stricter quality-assurance program. (NEC calls this quality grade "special grade").

The μ PD78011H(A), 78012H(A), 78013H(A), and 78014H(A) are the products in the μ PD78014H subseries within the 78K/0 series.

Compared with the older μ PD78018F subseries, this subseries reduces the EMI (Electro Magnetic Interface) noise generated from the microcontroller.

Functions are described in detail in the following User's Manual, which should be read when carrying out design work.

μ PD78014H Subseries User's Manual: Planned to publish
78K/0 Series User's Manual – Instruction: IEU-1372

FEATURES

- Low EMI noise model
- Large on-chip ROM & RAM

Item Product Name	Program Memory (ROM)	Data Memory		Package
		Internal High-Speed RAM	Internal Buffer RAM	
μ PD78011H(A)	8K bytes	512 bytes	32 bytes	<ul style="list-style-type: none"> • 64-pin plastic shrink DIP (750 mil) • 64-pin plastic QFP (14 × 14 mm)
μ PD78012H(A)	16K bytes			
μ PD78013H(A)	24K bytes	1024 bytes		
μ PD78014H(A)	32K bytes			

- External memory expansion space : 64K bytes
- Instruction execution time can be varied from high-speed (0.4 μ s) to ultra-low-speed (122 μ s)
- I/O ports: 53 (N-ch open-drain : 4)
- 8-bit resolution A/D converter : 8 channels
- Serial interface : 2 channels
- Timer : 5 channels
- Supply voltage : $V_{DD} = 1.8$ to 5.5 V

APPLICATION FIELD

Control unit of automotive, gas leak breaker, and safety devices, etc.

The information in this document is subject to change without notice.

ORDERING INFORMATION

Part Number	Package
μPD78011HCW(A)-xxx	64-pin plastic shrink DIP (750 mil)
μPD78011HGC(A)-xxx-AB8	64-pin plastic QFP (14 × 14 mm)
μPD78012HCW(A)-xxx	64-pin plastic shrink DIP (750 mil)
μPD78012HGC(A)-xxx-AB8	64-pin plastic QFP (14 × 14 mm)
μPD78013HCW(A)-xxx	64-pin plastic shrink DIP (750 mil)
μPD78013HGC(A)-xxx-AB8	64-pin plastic QFP (14 × 14 mm)
μPD78014HCW(A)-xxx	64-pin plastic shrink DIP (750 mil)
μPD78014HGC(A)-xxx-AB8	64-pin plastic QFP (14 × 14 mm)

Remark xxx indicates ROM code No.

Please refer to "Quality Grades on NEC Semiconductor Devices" (Document No. C11531E) published by NEC Corporation to know the specification of quality grade on the devices and its recommended applications.

78K/0 Series Expansion

The following shows the 78K/0 Series products development. Subseries name are shown inside frames.

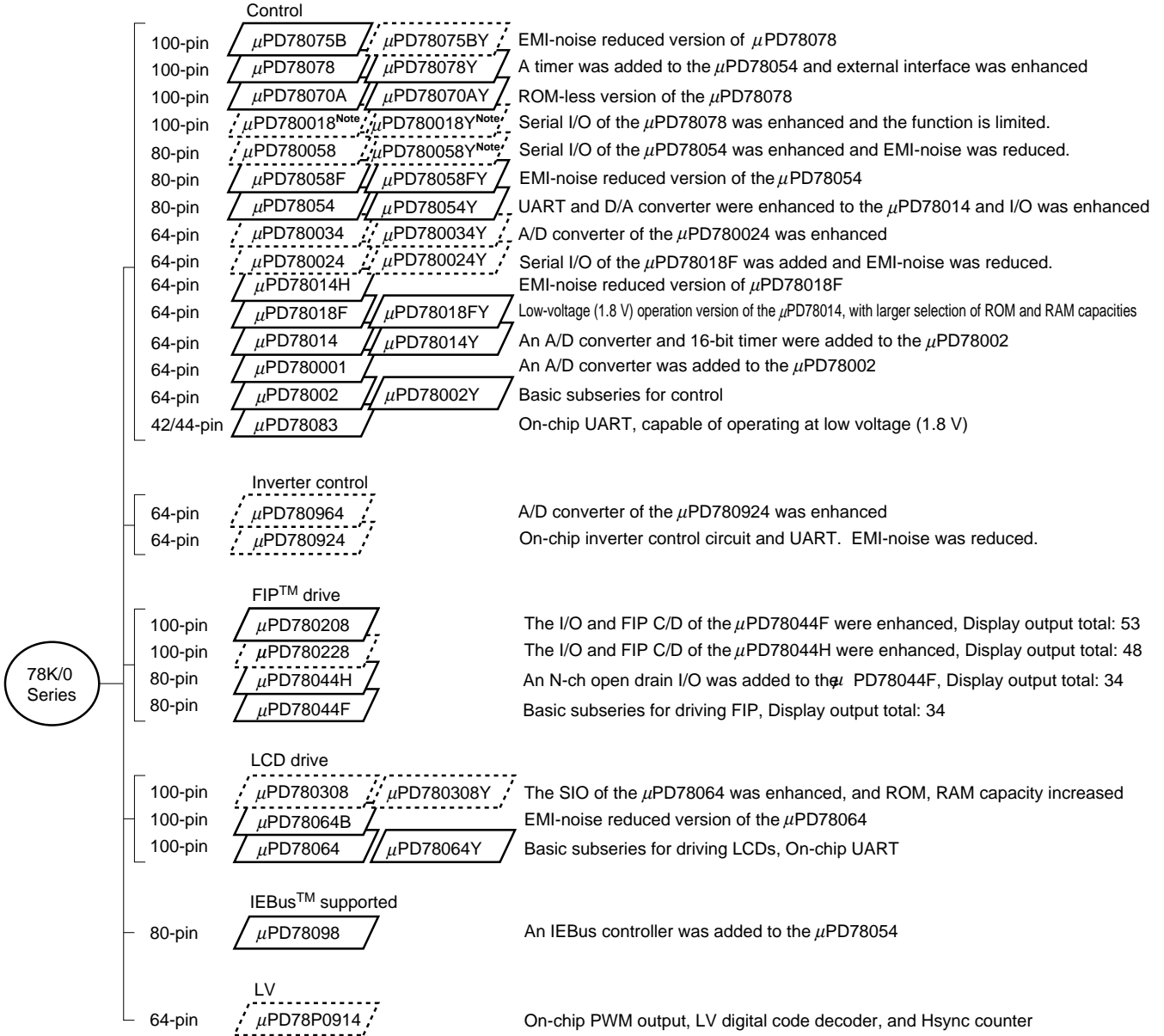
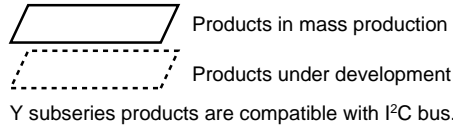

Note Under planning

The following lists the main functional differences between subseries products.

Function Subseries Name		ROM Capacity	Timer				8-bit A/D	10-bit A/D	8-bit D/A	Serial Interface	I/O	V _{DD} MIN. Value	External Expansion
			8-bit	16-bit	Watch	WDT							
Control	μPD78075B	32K-40K	4ch	1ch	1ch	1ch	8ch	-	2ch	3ch (UART: 1ch)	88	1.8 V	○
	μPD78078	48K-60K									61		
	μPD78070A	-											
	μPD780018	48K-60K	2ch						-	2ch (time division 3-wire: 1ch)	88		
	μPD780058	24K-60K							3ch (time division UART: 1ch)	68	1.8 V		
	μPD78058F	48K-60K	3ch (UART: 1ch)	69	2.7 V								
	μPD78054	16K-60K			2.0 V								
	μPD780034	8K-32K					-	8ch	-	3ch (UART: 1ch, time division 3-wire: 1ch)	51	1.8 V	
	μPD780024						8ch	-					
	μPD78014H												
	μPD78018F	8K-60K										2.7 V	
	μPD78014	8K-32K											
	μPD780001	8K		-	-					1ch	39		-
	μPD78002	8K-16K			1ch						53		○
μPD78083						8ch			1ch (UART: 1ch)	33	1.8 V	-	
Inverter control	μPD780964	8K-32K	3ch	Note	-	1ch	-	8ch	-	2ch (UART: 2ch)	47	2.7 V	○
	μPD780924						8ch	-					
FIP drive	μPD780208	32K-60K	2ch	1ch	1ch	1ch	8ch	-	-	2ch	74	2.7 V	-
	μPD780228	48K-60K									3ch		
	μPD78044H	32K-48K	2ch	1ch	1ch					68	2.7 V		
	μPD78044F	16K-40K								2ch			
LCD drive	μPD780308	48K-60K	2ch	1ch	1ch	1ch	8ch	-	-	3ch (time division UART: 1ch)	57	1.8 V	-
	μPD78064B	32K									2ch (UART: 1ch)	2.0 V	
	μPD78064	16K-32K											
IEBus supported	μPD78098	32K-60K	2ch	1ch	1ch	1ch	8ch	-	2ch	3ch (UART: 1ch)	69	2.7 V	○
LV	μPD78P0914	32K	6ch	-	-	1ch	8ch	-	-	2ch	54	4.5 V	○

Note 10-bit timer: 1 channel

OVERVIEW OF FUNCTION

Product Name		Item	μPD78011H(A)	μPD78012H(A)	μPD78013H(A)	μPD78014H(A)
Internal memory	ROM		8K bytes	16K bytes	24K bytes	32K bytes
	High-speed RAM		512 bytes		1024 bytes	
	Buffer RAM		32 bytes			
Memory space			64K bytes			
General-purpose registers			8 bits × 32 registers (8 bits × 8 registers × 4 banks)			
Instruction cycle			On-chip instruction execution time cycle modification function			
	When main system clock selected		0.4 μs/0.8 μs/1.6 μs/3.2 μs/6.4 μs (at 10.0 MHz operation)			
	When subsystem clock selected		122 μs (at 32.768 kHz operation)			
Instruction set			<ul style="list-style-type: none"> • 16-bit operation • Multiplication/division (8 bits × 8 bits, 16 bits ÷ 8 bits) • Bit manipulation (set, reset, test, boolean operation) • BCD correction, etc. 			
I/O ports			Total : 53 <ul style="list-style-type: none"> • CMOS input : 2 • CMOS I/O : 47 • N-channel open-drain I/O (15 V withstand voltage) : 4 			
A/D converter			<ul style="list-style-type: none"> • 8-bit resolution × 8 channels • Operable over a wide power supply voltage range: AV_{DD} = 1.8 to 5.5 V 			
Serial interface			<ul style="list-style-type: none"> • 3-wire serial I/O/SBI /2-wire serial I/O mode selectable: 1 channel • 3-wire serial I/O mode (on-chip max. 32 bytes automatic data transmit/receive function): 1 channel 			
Timer			<ul style="list-style-type: none"> • 16-bit timer/event counter : 1 channel • 8-bit timer/event counter : 2 channels • Watch timer : 1 channel • Watchdog timer : 1 channel 			
Timer output			3 (14-bit PWM output × 1)			
Clock output			39.1 kHz, 78.1 kHz, 156 kHz, 313 kHz, 625 kHz, 1.25 MHz (at main system clock: 10.0 MHz operation), 32.768 kHz (at subsystem clock: 32.768 kHz operation)			
Buzzer output			2.4 kHz, 4.9 kHz, 9.8 kHz (at main system clock: 10.0 MHz operation)			
Vectored interrupt sources	Maskable		Internal : 8, External : 4			
	Non-maskable		Internal : 1			
	Software		1			
Test input			Internal : 1, External : 1			
Supply voltage			V _{DD} = 1.8 to 5.5 V			
Operating ambient temperature			T _A = -40 to +85°C			
Package			<ul style="list-style-type: none"> • 64-pin plastic shrink DIP (750 mil) • 64-pin plastic QFP (14 × 14 mm) 			

TABLE OF CONTENTS

1. PIN CONFIGURATION (Top View) 7

2. BLOCK DIAGRAM 10

3. PIN FUNCTIONS 11

 3.1 PORT PINS 11

 3.2 OTHER PORTS 12

 3.3 PIN I/O CIRCUIT AND RECOMMENDED CONNECTION OF UNUSED PINS 14

4. MEMORY SPACE 16

5. PERIPHERAL HARDWARE FUNCTION FEATURES 17

 5.1 PORTS 17

 5.2 CLOCK GENERATOR 18

 5.3 TIMER/EVENT COUNTER 19

 5.4 CLOCK OUTPUT CONTROL CIRCUIT 21

 5.5 BUZZER OUTPUT CONTROL CIRCUIT 21

 5.6 A/D CONVERTER 22

 5.7 SERIAL INTERFACES 23

6. INTERRUPT FUNCTIONS AND TEST FUNCTIONS 25

 6.1 INTERRUPT FUNCTIONS 25

 6.2 TEST FUNCTIONS 28

7. EXTERNAL DEVICE EXPANSION FUNCTIONS 29

8. STANDBY FUNCTIONS 29

9. RESET FUNCTIONS 29

10. INSTRUCTION SET 30

11. ELECTRICAL SPECIFICATIONS 33

12. PACKAGE DRAWINGS 57

13. RECOMMENDED SOLDERING CONDITIONS 59

APPENDIX A. DEVELOPMENT TOOLS 60

APPENDIX B. RELATED DOCUMENTS 62

1. PIN CONFIGURATION (Top View)

• 64-Pin Plastic Shrink DIP (750 mil)

μPD78011HCW(A)-xxx, 78012HCW(A)-xxx, 78013HCW(A)-xxx, 78014HCW(A)-xxx

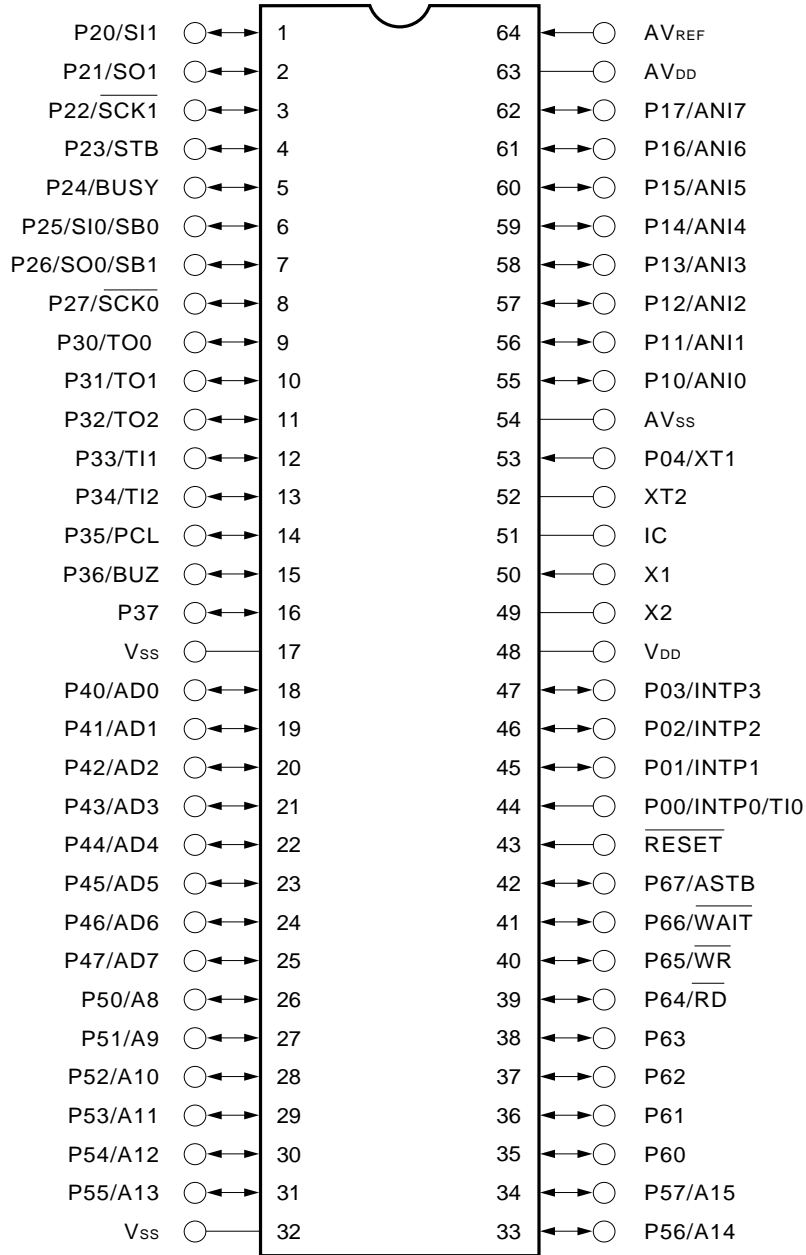

- Cautions**
1. Always connect the IC (Internally Connected) pin to Vss directly.
 2. The AVDD pin is multiplexed with an A/D converter power pin and a port power pin. In an application where the noise generated from the microcontroller must be reduced, connect the AVDD pin to a power supply of the same voltage as VDD.
 3. The AVss pin is multiplexed with an A/D converter ground pin and a port ground pin. In an application where the noise generated from the microcontroller must be reduced, connect AVss pin to a ground line separate from Vss.

• 64-Pin Plastic QFP (14 × 14 mm)

μPD78011HGC(A)-xxx-AB8, 78012HGC(A)-xxx-AB8, 78013HGC(A)-xxx-AB8, 78014HGC(A)-xxx-AB8

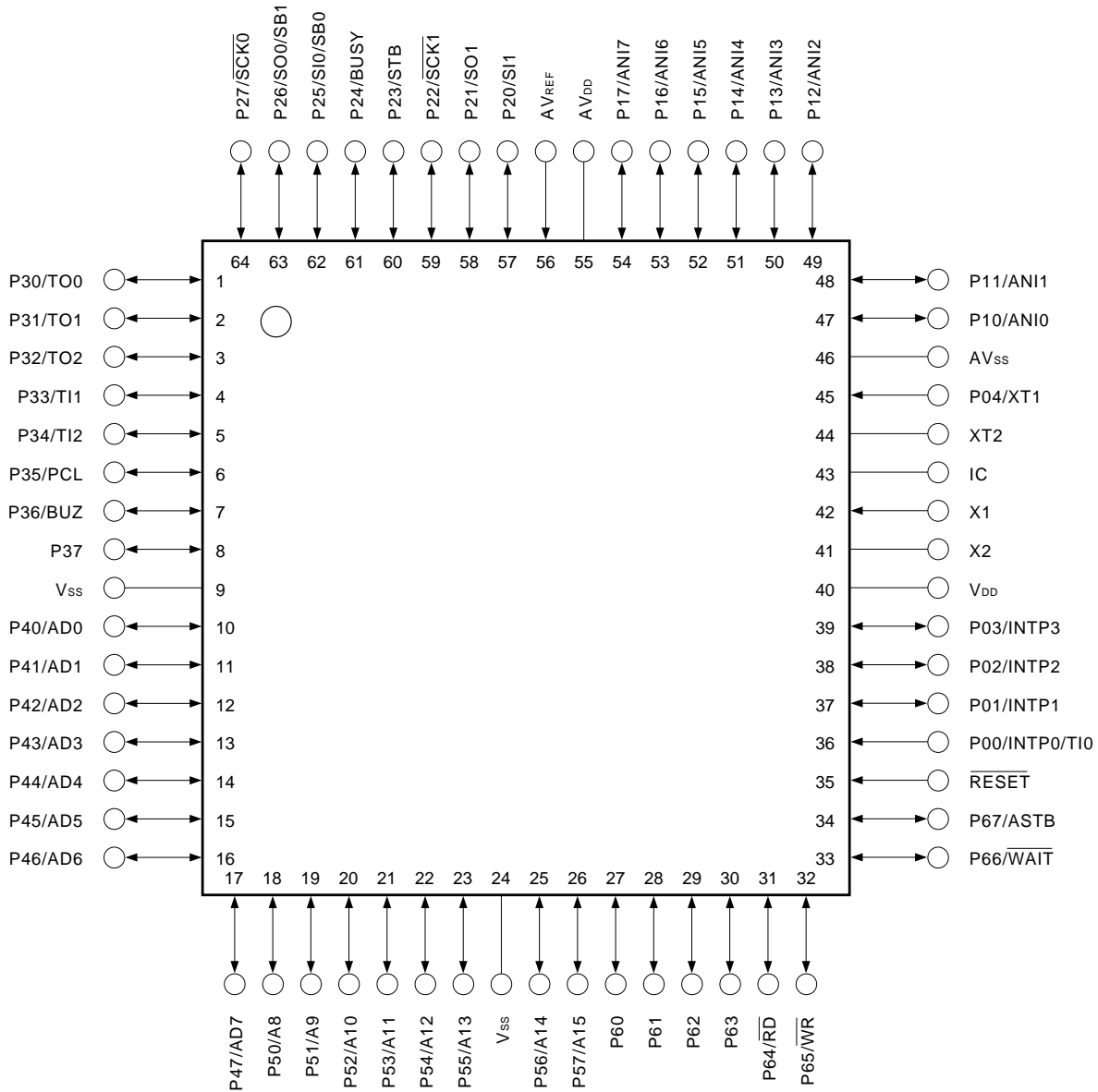

- Cautions**
1. Always connect the IC (Internally Connected) pin to V_{SS} directly.
 2. The AV_{DD} pin is multiplexed with an A/D converter power pin and a port power pin. In an application where the noise generated from the microcontroller must be reduced, connect the AV_{DD} pin to a power supply of the same voltage as V_{DD}.
 3. The AV_{SS} pin is multiplexed with an A/D converter ground pin and a port ground pin. In an application where the noise generated from the microcontroller must be reduced, connect AV_{SS} pin to a ground line separate from V_{SS}.

A8-A15	: Address Bus	P60-P67	: Port 6
AD0-AD7	: Address/Data Bus	PCL	: Programmable Clock
ANI0-ANI7	: Analog Input	\overline{RD}	: Read Strobe
ASTB	: Address Strobe	\overline{RESET}	: Reset
AVDD	: Analog Power Supply	SB0, SB1	: Serial Bus
AVREF	: Analog Reference Voltage	$\overline{SCK0}, \overline{SCK1}$: Serial Clock
AVSS	: Analog Ground	SI0, SI1	: Serial Input
BUSY	: Busy	SO0, SO1	: Serial Output
BUZ	: Buzzer Clock	STB	: Strobe
IC	: Internally Connected	TI0-TI2	: Timer Input
INTP0-INTP3	: Interrupt from Peripherals	TO0-TO2	: Timer Output
P00-P04	: Port 0	VDD	: Power Supply
P10-P17	: Port 1	VSS	: Ground
P20-P27	: Port 2	\overline{WAIT}	: Wait
P30-P37	: Port 3	\overline{WR}	: Write Strobe
P40-P47	: Port 4	X1, X2	: Crystal (Main System Clock)
P50-P57	: Port 5	XT1, XT2	: Crystal (Subsystem Clock)

2. BLOCK DIAGRAM

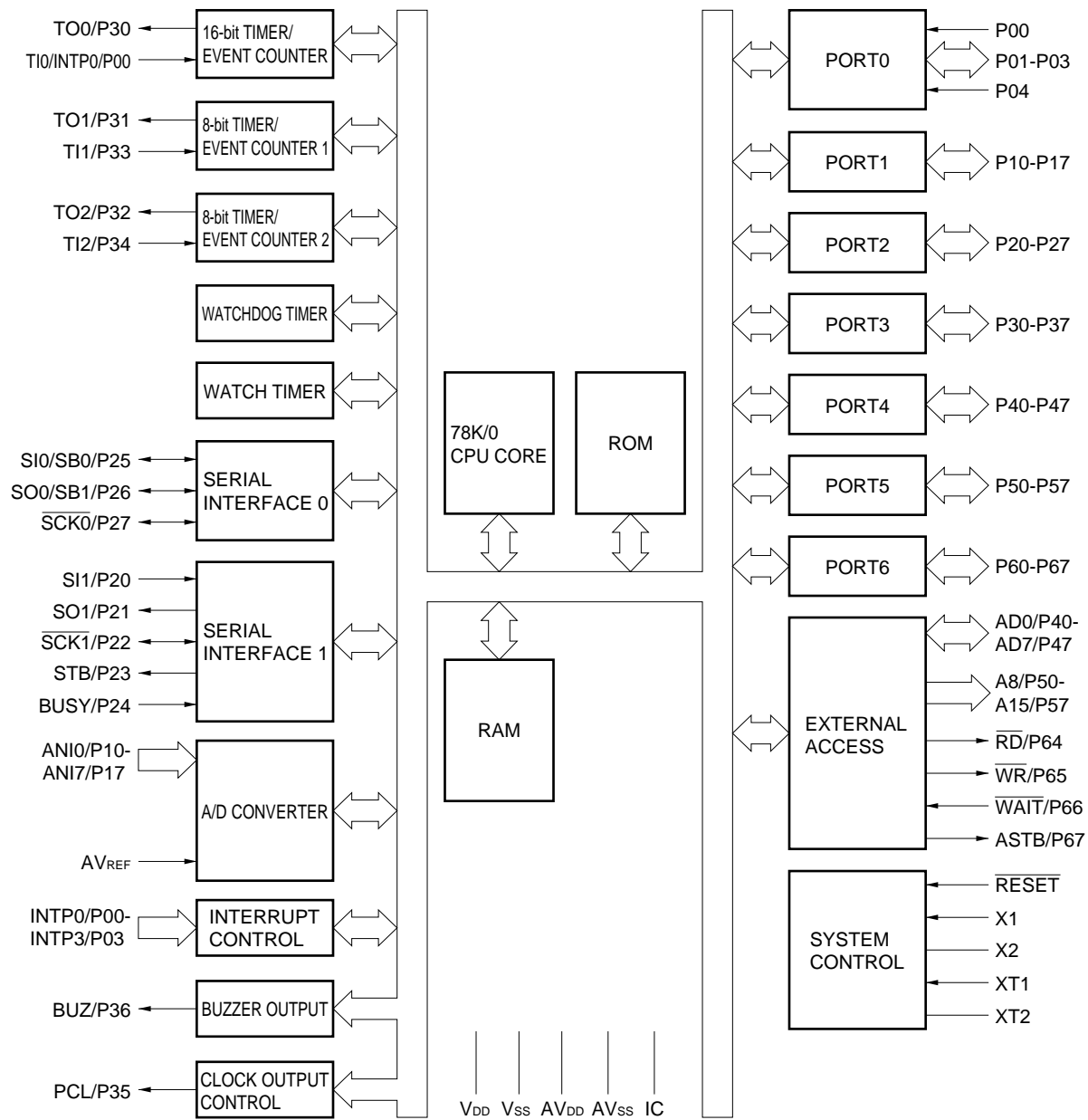

Remark Internal ROM & RAM capacity varies depending on the product.

3. PIN FUNCTIONS

3.1 PORT PINS (1/2)

Pin Name	I/O	Function		On Reset	Dual-Function Pin
P00	Input	Port 0 5-bit I/O port	Input only	Input	INTP0/TI0
P01	Input/ output		Input/output can be specified bit-wise. When used as an input port, on-chip pull-up resistor can be used by software.	Input	INTP1
P02					INTP2
P03					INTP3
P04 ^{Note 1}	Input		Input only	Input	XT1
P10 to P17	Input/ output	Port 1 8-bit input/output port. Input/output can be specified bit-wise. When used as an input port, on-chip pull-up resistor can be used by software. ^{Note 2}		Input	ANI0 to ANI7
P20	Input/ output	Port 2 8-bit input/output port. Input/output can be specified bit-wise. When used as an input port, on-chip pull-up resistor can be used by software.		Input	SI1
P21					SO1
P22					SCK1
P23					STB
P24					BUSY
P25					SI0/SB0
P26					SO0/SB1
P27					SCK0
P30	Input/ output	Port 3 8-bit input/output port. Input/output can be specified in 1-bit units. When used as an input port, on-chip pull-up resistor can be used by software.		Input	TO0
P31					TO1
P32					TO2
P33					TI1
P34					TI2
P35					PCL
P36					BUZ
P37					—
P40 to P47	Input/ output	Port 4 8-bit input/output port. Input/output can be specified in 8-bit unit. When used as an input port, on-chip pull-up resistor can be used by software. Test input flag (KRIF) is set to 1 by falling edge detection.		Input	AD0 to AD7

Notes 1. When using the P04/XT1 pin as an input port pin, set bit 6 (FRC) of the processor clock control register (PCC) to 1 (do not use the internal feedback resistor of the subsystem clock oscillation circuit).

2. When using the P10/ANI0 through P17/ANI7 pins as the analog input pins of the A/D converter, the internal pull-up resistors are automatically not used.

3.1 PORT PINS (2/2)

Pin Name	I/O	Function		On Reset	Dual-Function Pin
P50 to P57	Input/output	Port 5 8-bit input/output port. LED can be driven directly. Input/output can be specified bit-wise. When used as an input port, on-chip pull-up resistor can be used by software.		Input	A8 to A15
P60	Input/output	Port 6 8-bit input/output port. Input/output can be specified bit-wise.	N-ch open-drain input/output port. On-chip pull-up resistor can be specified by mask option. LED can be driven directly.	Input	—
P61					
P62					
P63					
P64		When used as an input port, on-chip pull-up resistor can be used by software.	\overline{RD}		
P65			\overline{WR}		
P66			\overline{WAIT}		
P67			ASTB		

Caution Do not manipulate the pins multiplexed with a port pin as follows during A/D conversion; otherwise, the rated total error during A/D conversion may not be satisfied.

<1> Rewriting the contents of the output latch when the pin is used as an output port pin.

<2> Changing the output level of the pin used as an output pin even when the pin is not used as a port pin.

3.2 OTHER PORTS (1/2)

Pin Name	I/O	Function		On Reset	Dual-Function Pin
INTP0	Input	External interrupt request input by which the effective edge (rising edge, falling edge, or both rising edge and falling edge) can be specified.		Input	P00/T10
INTP1					P01
INTP2		P02			
INTP3		Falling edge detection external interrupt request input.			P03
SI0	Input	Serial interface serial data input.		Input	P25/SB0
SI1					P20
SO0	Output	Serial interface serial data output.		Input	P26/SB1
SO1					P21
SB0	Input/output	Serial interface serial data input/output.		Input	P25/SI0
SB1					P26/SO0
$\overline{SCK0}$	Input/output	Serial interface serial clock input/output.		Input	P27
$\overline{SCK1}$					P22
STB	Output	Serial interface automatic transmit/receive strobe output.		Input	P23
BUSY	Input	Serial interface automatic transmit/receive busy input.		Input	P24

3.2 OTHER PORTS (2/2)

Pin Name	I/O	Function	On Reset	Dual-Function Pin
T10	Input	External count clock input to 16-bit timer (TM0).	Input	P00/INTP0
T11		External count clock input to 8-bit timer (TM1).		P33
T12		External count clock input to 8-bit timer (TM2).		P34
TO0	Output	16-bit timer (TM0) output (multiplexed with 14-bit PWM output).	Input	P30
TO1		8-bit timer (TM1) output.		P31
TO2		8-bit timer (TM2) output.		P32
PCL	Output	Clock output (for main system clock, subsystem clock trimming).	Input	P35
BUZ	Output	Buzzer output.	Input	P36
AD0 to AD7	Input /output	Low-order address/data bus at external memory expansion.	Input	P40 to P47
A8 to A15	Output	High-order address bus at external memory expansion.	Input	P50 to P57
\overline{RD}	Output	External memory read operation strobe signal output.	Input	P64
\overline{WR}		External memory write operation strobe signal output.		P65
\overline{WAIT}	Input	Wait insertion at external memory access.	Input	P66
ASTB	Output	Strobe output which latches the address information output at port 4 and port 5 to access external memory.	Input	P67
ANI0 to ANI7	Input	A/D converter analog input.	Input	P10 to P17
AVREF	Input	A/D converter reference voltage input.	—	—
AVDD	—	A/D converter analog power supply (multiplexed with a port power pin).	—	—
AVSS	—	A/D converter ground potential (multiplexed with a port ground pin).	—	—
\overline{RESET}	Input	System reset input.	—	—
X1	Input	Main system clock oscillation crystal connection.	—	—
X2	—		—	—
XT1	Input	Subsystem clock oscillation crystal connection.	Input	P04
XT2	—		—	—
VDD	—	Positive power supply (except port pins).	—	—
VSS	—	Ground potential (except port pins).	—	—
IC	—	Internal connection. Connected to VSS directly.	—	—

- Cautions**
1. The AVDD pin is multiplexed with an A/D converter power pin and a port power pin. In an application where the noise generated from the microcontroller must be reduced, connect the AVDD pin to a power supply of the same voltage as VDD.
 2. The AVSS pin is multiplexed with an A/D converter ground pin and a port ground pin. In an application where the noise generated from the microcontroller must be reduced, connect AVSS pin to a ground line separate from VSS.

3.3 PIN I/O CIRCUITS AND RECOMMENDED CONNECTION OF UNUSED PINS

The input/output circuit type of each pin and recommended connection of unused pins are shown in Table 3-1. For the input/output circuit configuration of each type, see Figure 3-1.

Table 3-1. Input/Output Circuit Type of Each Pin

Pin Name	Input/output Circuit Type	I/O	Recommended Connection when Not Used	
P00/INTP0/TI0	2	Input	Connected to V _{SS} .	
P01/INTP1	8-D	Input/output	Individually connected to V _{SS} via resistor.	
P02/INTP2				
P03/INTP3				
P04/XT1	16	Input	Connected to V _{DD} or V _{SS} .	
P10/ANI0 to P17/ANI7	11-C	Input/output	Individually connected to V _{DD} or V _{SS} via resistor.	
P20/SI1	8-D			
P21/SO1	5-J			
P22/ $\overline{\text{SCK}}1$	8-D			
P23/STB	5-J			
P24/BUSY	8-D			
P25/SI0/SB0	10-C			
P26/SO0/SB1				
P27/ $\overline{\text{SCK}}0$				
P30/TO0	5-J			
P31/TO1				
P32/TO2				
P33/TI1	8-D			
P34/TI2				
P35/PCL	5-J			
P36/BUZ				
P37				
P40/AD0 to P47/AD7	5-O			Individually connected to V _{DD} via resistor.
P50/A8 to P57/A15	5-J			Individually connected to V _{DD} or V _{SS} via resistor.
P60 to P63	13-I			Individually connected to V _{DD} via resistor.
P64/ $\overline{\text{RD}}$	5-J			Individually connected to V _{DD} or V _{SS} via resistor.
P65/ $\overline{\text{WR}}$				
P66/ $\overline{\text{WAIT}}$				
P67/ASTB				
$\overline{\text{RESET}}$	2	Input	—	
XT2	16	—	Leave open.	
AV _{REF}	—	—	Connected to V _{SS} .	
AV _{DD}			Connected to V _{DD} .	
AV _{SS}			Connected to V _{SS} .	
IC			Connected to V _{SS} directly.	

Figure 3-1. Pin Input/Output Circuits

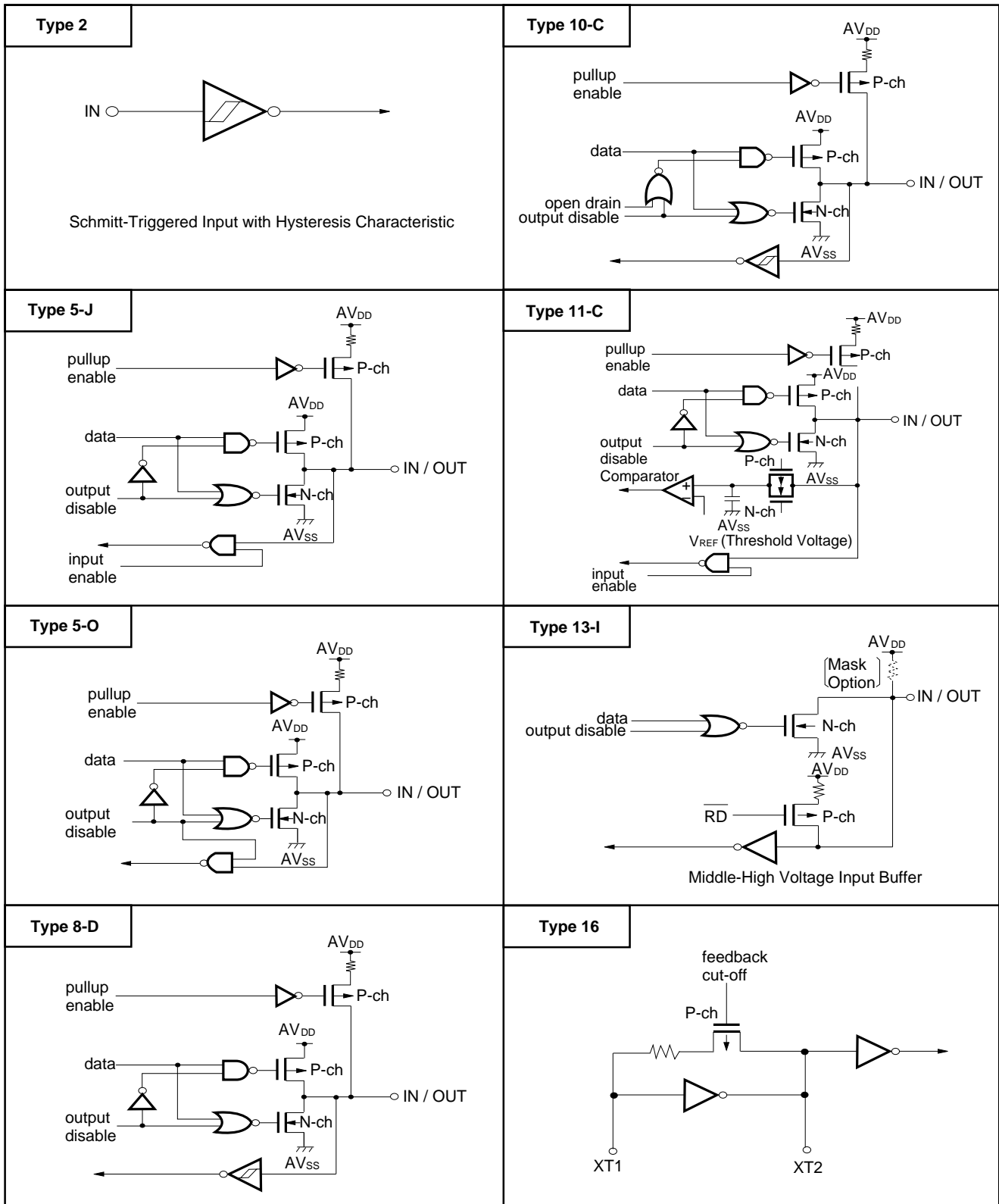

4. MEMORY SPACE

The memory map of the μPD78011H(A), 78012H(A), 78013H(A), 78014H(A) is shown in Figure 4-1.

Figure 4-1. Memory Map

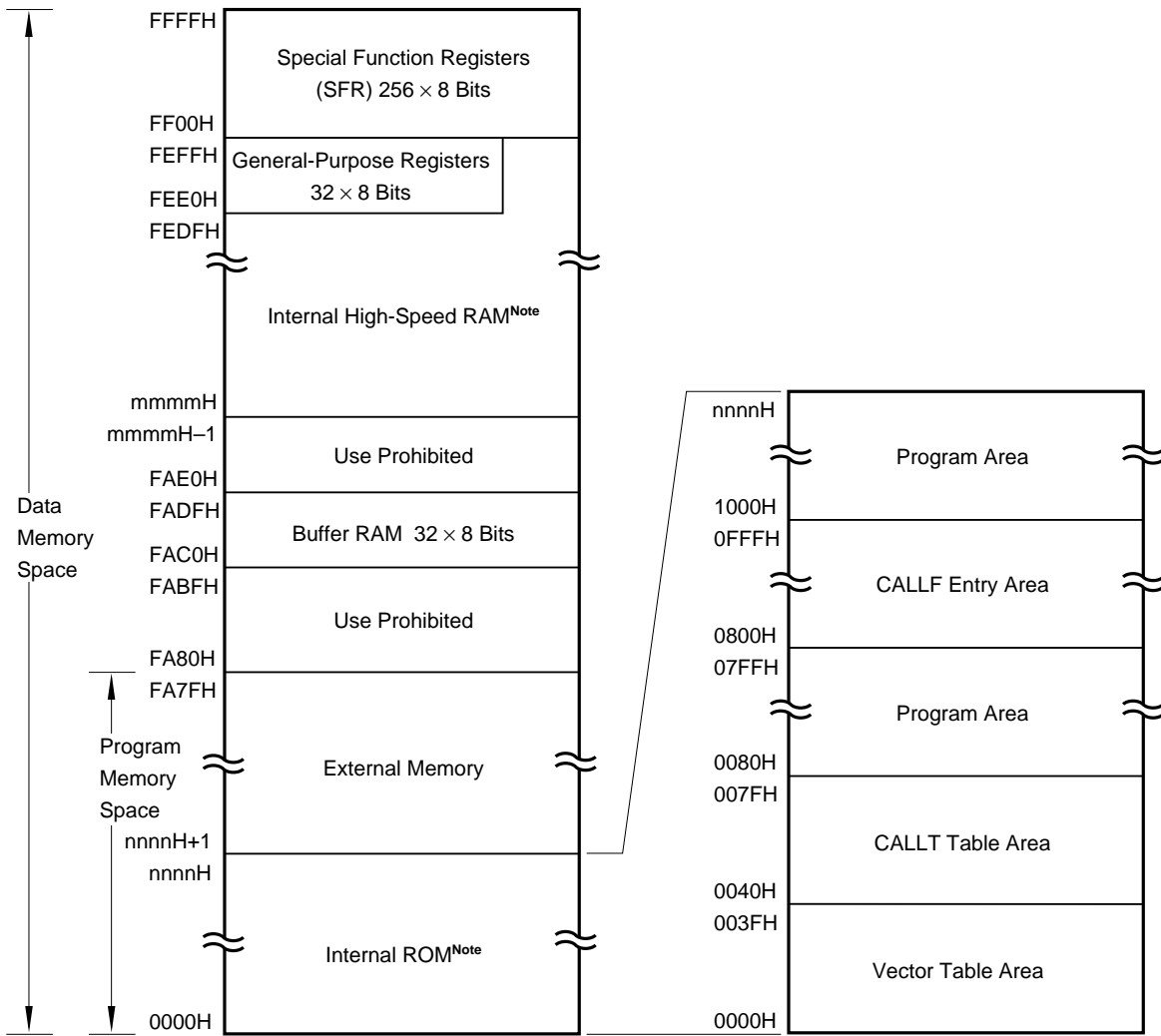

Note Internal ROM and internal high-speed RAM capacities vary depending on the product (see the table below).

Product Name	Internal ROM End Address n n n n H	Internal High-Speed RAM Start Address m m m m H
μPD78011H(A)	1FFFH	FD00H
μPD78012H(A)	3FFFH	
μPD78013H(A)	5FFFH	FB00H
μPD78014H(A)	7FFFH	

5. PERIPHERAL HARDWARE FUNCTION FEATURES

5.1 PORTS

The I/O port has the following three types

- CMOS input (P00, P04) : 2
 - CMOS input/output (P01 to P03, port 1 to port 5, P64 to P67) : 47
 - N-ch open-drain input/output(15V withstand voltage) (P60 to P63) : 4
-
- Total : 53

Table 5-1. Functions of Ports

Port Name	Pin Name	Function
Port 0	P00, P04	Dedicated Input port
	P01 to P03	Input/output ports. Input/output can be specified bit-wise. When used as an input port, pull-up resistor can be used by software.
Port 1	P10 to P17	Input/output ports. Input/output can be specified bit-wise. When used as an input port, pull-up resistor can be used by software.
Port 2	P20 to P27	Input/output ports. Input/output can be specified bit-wise. When used as an input port, pull-up resistor can be used by software.
Port 3	P30 to P37	Input/output ports. Input/output can be specified bit-wise. When used as an input port, pull-up resistor can be used by software.
Port 4	P40 to P47	Input/output ports. Input/output can be specified in 8-bit units. When used as an input port, pull-up resistor can be used by software. Test input flag (KRIF) is set to 1 by falling edge detection.
Port 5	P50 to P57	Input/output ports. Input/output can be specified bit-wise. When used as an input port, pull-up resistor can be used by software. LED can be driven directly.
Port 6	P60 to P63	N-ch open-drain input/output port. Input/output can be specified bit-wise. On-chip pull-up resistor can be specified by mask option. LED can be driven directly.
	P64 to P67	Input/output ports. Input/output can be specified bit-wise. When used as an input port, pull-up resistor can be used by software.

5.2 CLOCK GENERATOR

There are two types of clock generator: main system clock and subsystem clock.
The instruction execution time can be changed.

- $0.4\mu\text{s}/0.8\mu\text{s}/1.6\mu\text{s}/3.2\mu\text{s}/6.4\mu\text{s}$ (Main system clock: at 10.0 MHz operation)
- $122\mu\text{s}$ (Subsystem clock: at 32.768 KHz operation)

Figure 5-1. Clock Generator Block Diagram

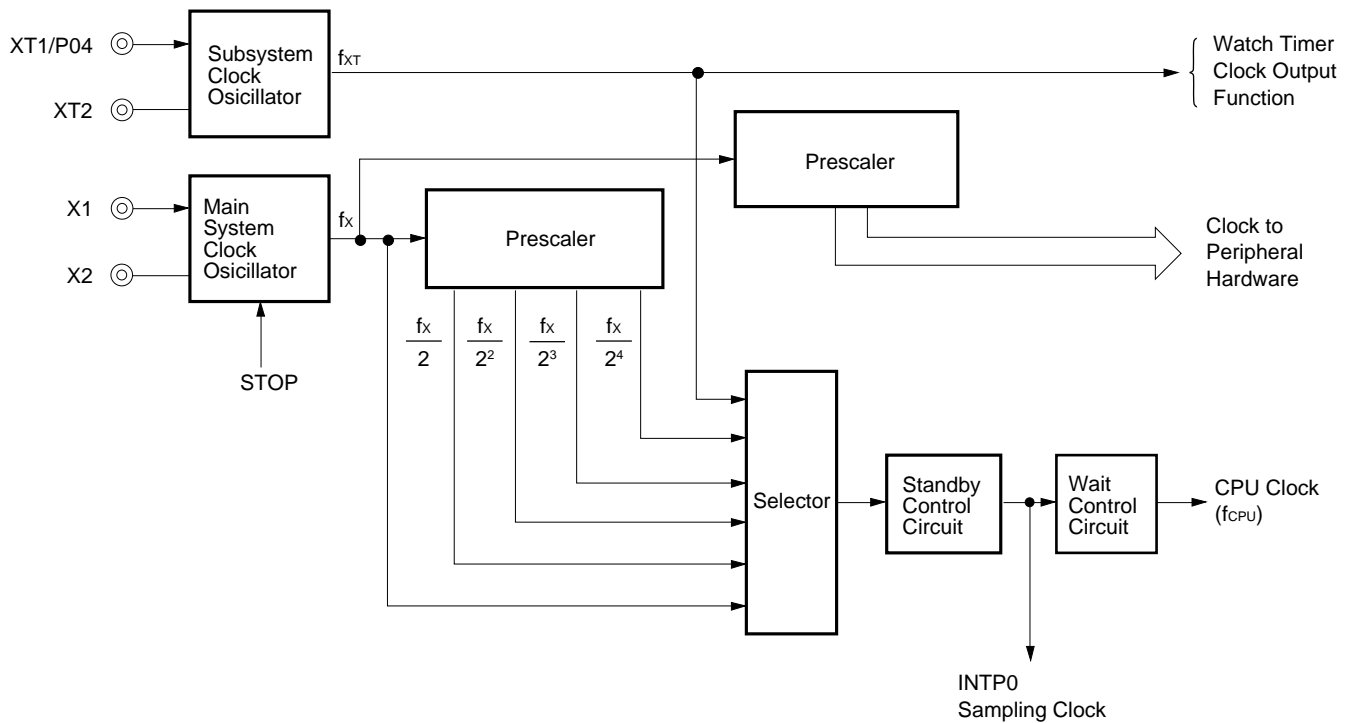

5.3 TIMER/EVENT COUNTER

The following five channels are incorporated in the timer/event counter.

- 16-bit timer/event counter : 1 channel
- 8-bit timer/event counter : 2 channels
- Watch timer : 1 channel
- Watchdog timer : 1 channel

Table 5-2. Types and Functions of Timer/Event Counter

		16-bit Timer/Event Counter	8-bit Timer/Event Counter	Watch Timer	Watchdog Timer
Type	Interval timer	1 channel	2 channels	1 channel	1 channel
	External event counter	1 channel	2 channels	–	–
Functions	Timer output	1 output	2 outputs	–	–
	PWM output	1 output	–	–	–
	Pulse width measurement	1 input	–	–	–
	Square wave output	1 output	2 outputs	–	–
	Interrupt request	2	2	1	1
	Test input	–	–	1	–

Figure 5-2. 16-bit Timer/Event Counter Block Diagram

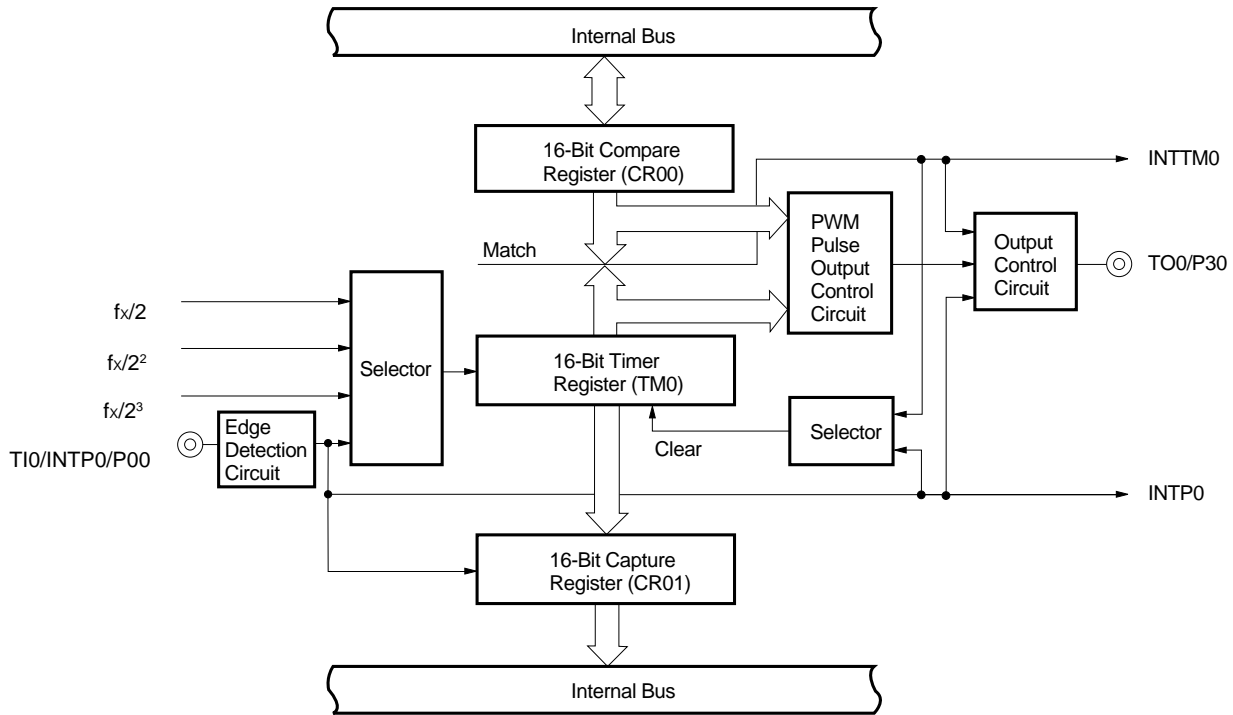

Figure 5-3. 8-bit Timer/Event Counter Block Diagram

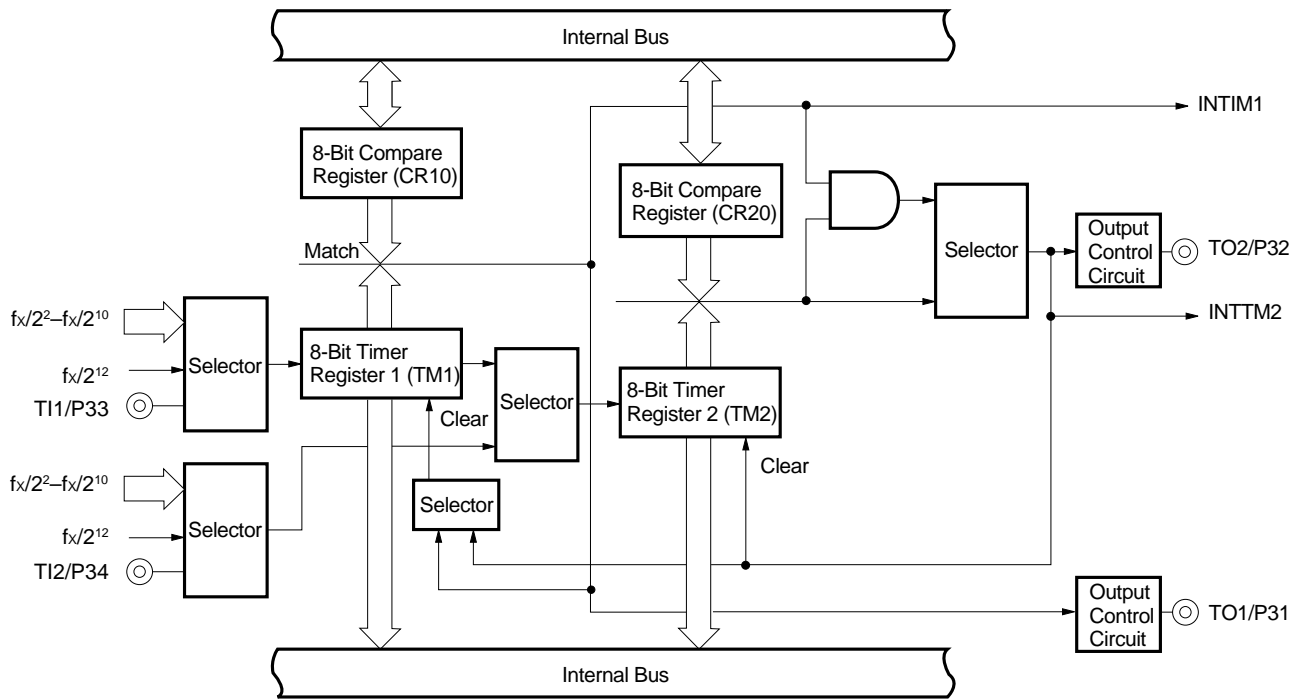

Figure 5-4. Watch Timer Block Diagram

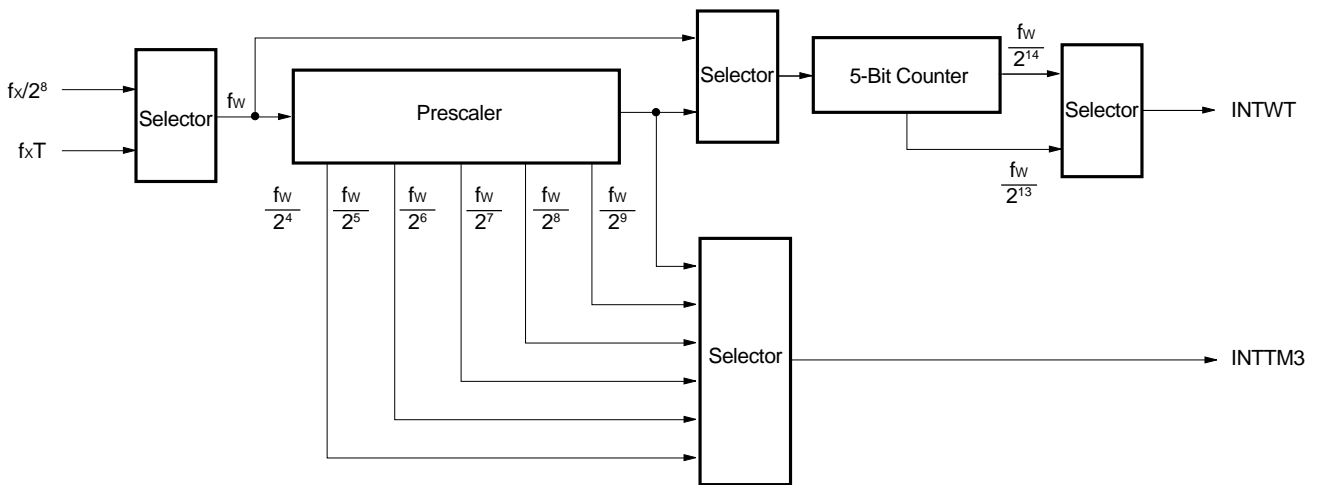
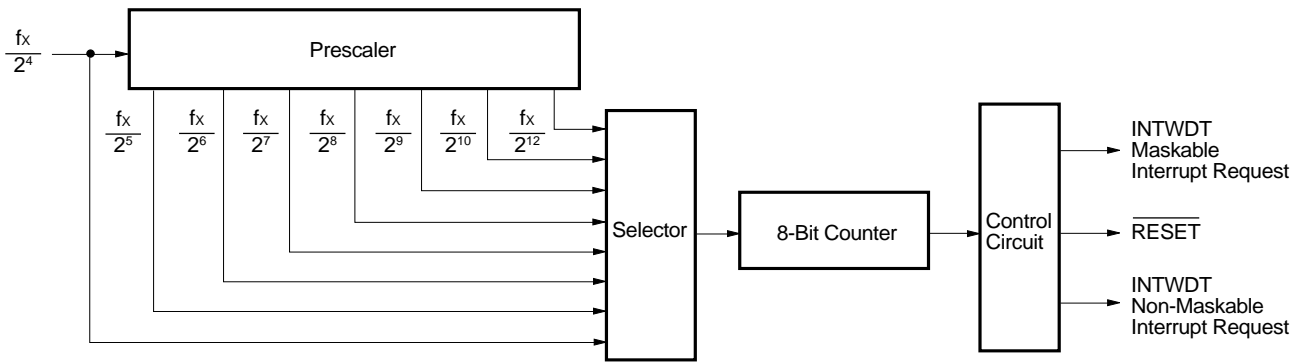

Figure 5-5. Watchdog Timer Block Diagram



5.4 CLOCK OUTPUT CONTROL CIRCUIT

The clock with the following frequencies can be output for clock output.

- 39.1 kHz/78.1 kHz/156 kHz/313 kHz/625 kHz/1.25 MHz (Main system clock: at 10.0 MHz operation)
- 32.768 kHz (Subsystem clock: at 32.768 kHz operation)

Figure 5-6. Clock Output Control Block Diagram

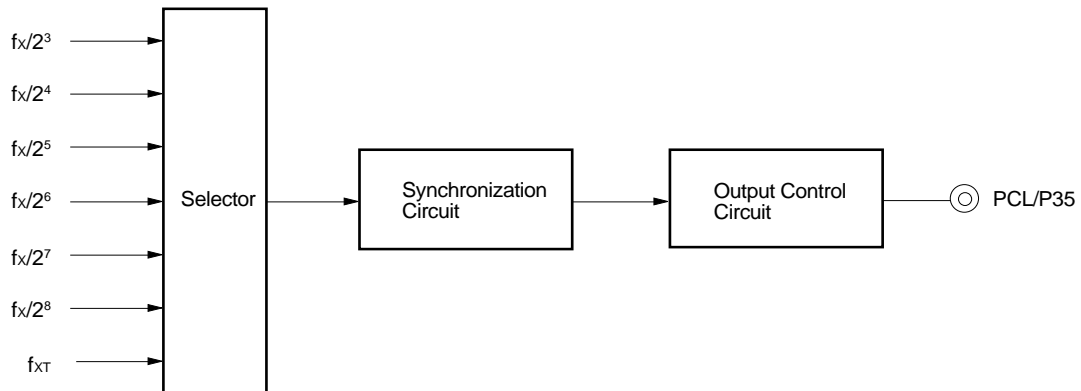

5.5 BUZZER OUTPUT CONTROL CIRCUIT

The clock with the following frequencies can be output for buzzer output.

- 2.4 kHz/4.9 kHz/9.8 kHz (Main system clock: at 10.0 MHz operation)

Figure 5-7. Buzzer Output Control Block Diagram

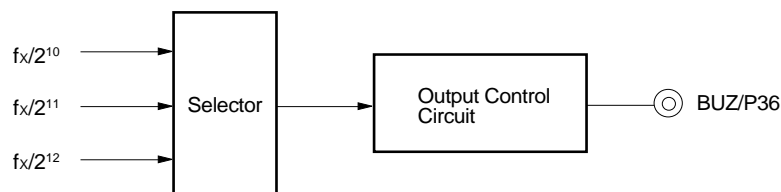

5.6 A/D CONVERTER

The A/D converter has on-chip eight 8-bit resolution channels. There are the following two method to start A/D conversion.

- Hardware starting
- Software starting

Figure 5-8. A/D Converter Block Diagram

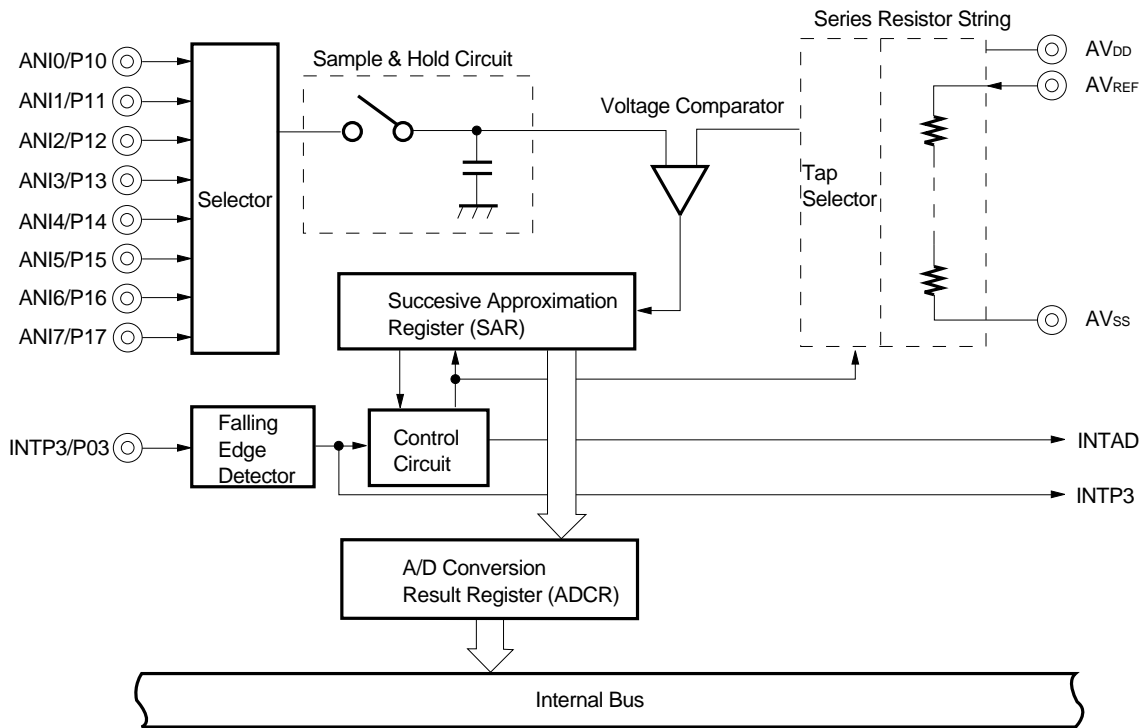

Caution Do not manipulate the pins multiplexed with a port pin (refer to 3.1 PORT PINS) during A/D conversion; otherwise, the rated total error during A/D conversion may not be satisfied.

- <1> Rewriting the contents of the output latch when the pin is used as an output port pin.
- <2> Changing the output level of the pin used as an output pin even when the pin is not used as a port pin.

5.7 SERIAL INTERFACES

There are two on-chip clocked serial interfaces as follows.

- Serial Interface channel 0
- Serial Interface channel 1

Table 5-3. Type and Function of Serial Interface

Function	Serial Interface Channel 0	Serial Interface Channel 1
3-wire serial I/O mode	○ (MSB/LSB-first switchable)	○ (MSB/LSB-first switchable)
3-wire serial I/O mode with automatic data transmit/receive function	–	○ (MSB/LSB-first switchable)
SBI (Serial Bus Interface) mode	○ (MSB-first)	–
2-wire serial I/O mode	○ (MSB-first)	–

Figure 5-9. Serial Interface Channel 0 Block Diagram

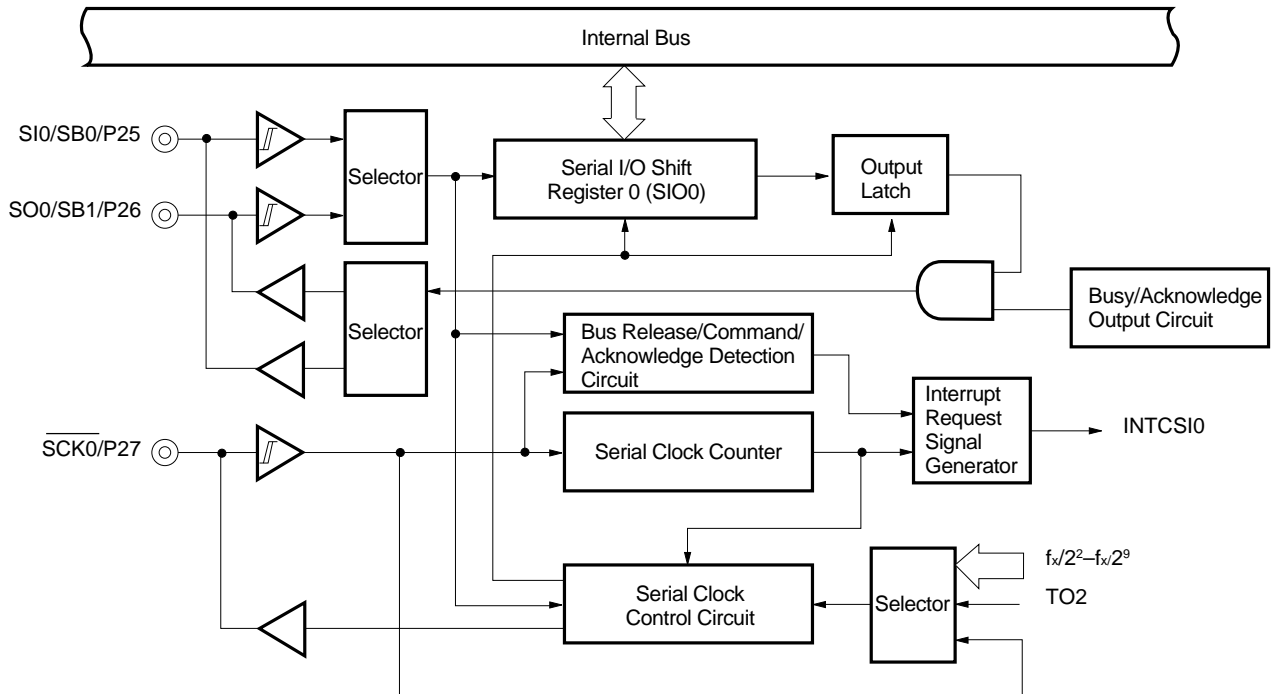
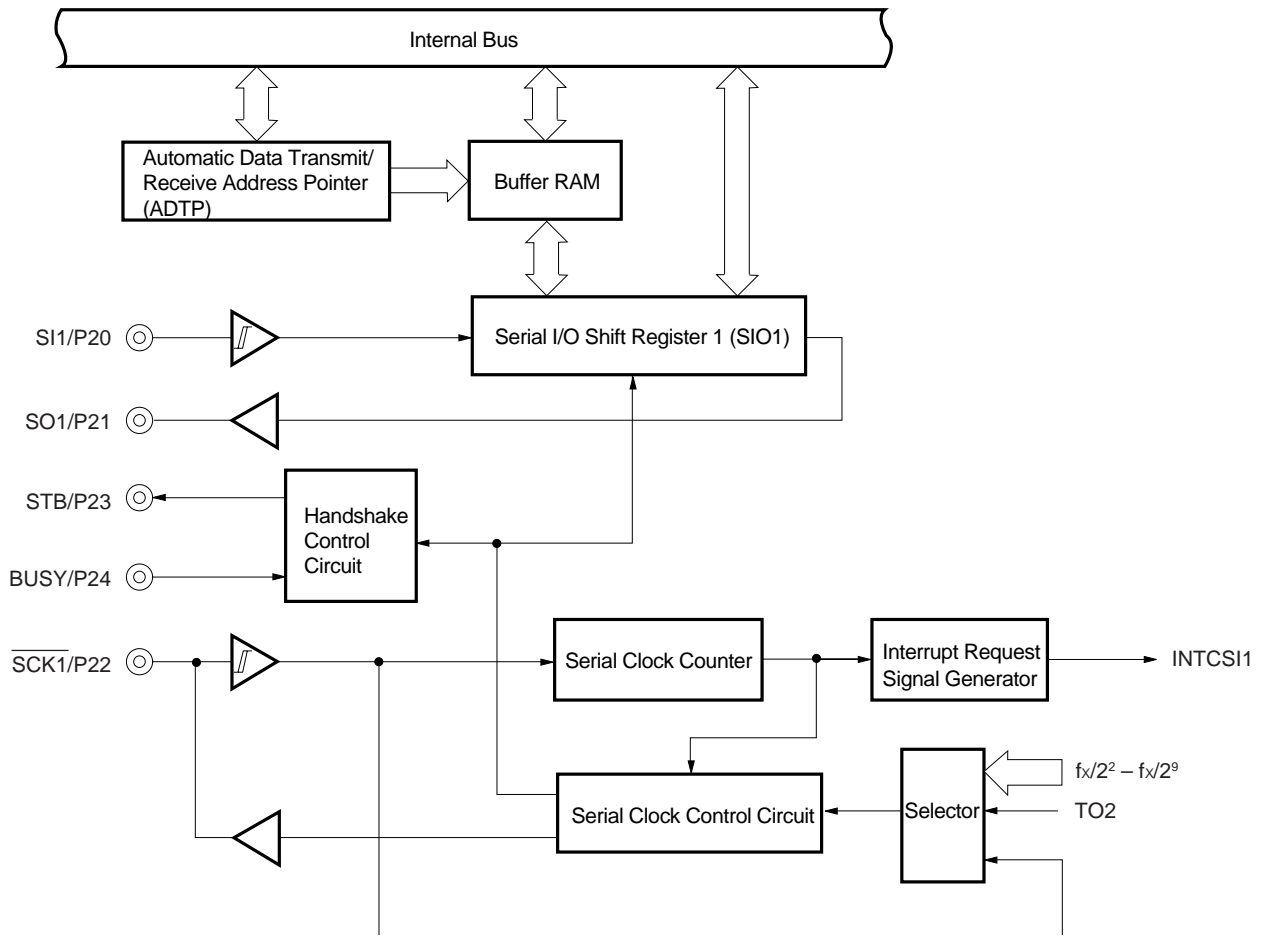

Figure 5-10. Serial Interface Channel 1 Block Diagram



6. INTERRUPT FUNCTIONS AND TEST FUNCTIONS

6.1 INTERRUPT FUNCTIONS

There are the 14 interrupt sources of 3 different kind as shown below.

- Non-maskable : 1
- Maskable : 12
- Software : 1

Table 6-1. Interrupt Source List

Interrupt Type	Default Priority ^{Note 1}	Interrupt Source		Internal/ External	Vector Table Address	Basic Configuratin Type ^{Note 2}		
		Name	Trigger					
Non-maskable	—	INTWDT	Watchdog timer overflow (with watchdog timer mode 1 selected)	Internal	0004H	(A)		
Maskable	0	INTWDT	Watchdog timer overflow (with interval timer mode selected)			External	0006H 0008H 000AH 000CH	(B)
	1	INTP0	Pin input edge detection	Internal	000EH 0010H 0012H 0014H 0016H 0018H 001AH			(C)
	2	INTP1						(D)
	3	INTP2						
	4	INTP3						
	5	INTCSI0	Serial interface channel 0 transfer end	Internal	000EH 0010H 0012H 0014H 0016H 0018H 001AH	(B)		
	6	INTCSI1	Serial interface channel 1 transfer end					
	7	INTTM3	Reference time interval signal from watch timer					
	8	INTTM0	16 bit timer/event counter match signal generation					
	9	INTTM1	8-bit timer/event counter 1 match signal generation					
	10	INTTM2	8-bit timer/event counter 2 match signal generation					
11	INTAD	A/D converter conversion end						
Software	—	BRK	BRK instruction execution	—	003EH	(E)		

Notes 1. The default priority is the priority applicable when more than one maskable interrupt is generated. 0 is the highest priority and 11, the lowest.

2. Basic configuration types (A) to (E) correspond to (A) to (E) on the next page.

Figure 6-1. Basic Interrupt Function Configuration (1/2)

(A) Internal Non-Maskable Interrupt

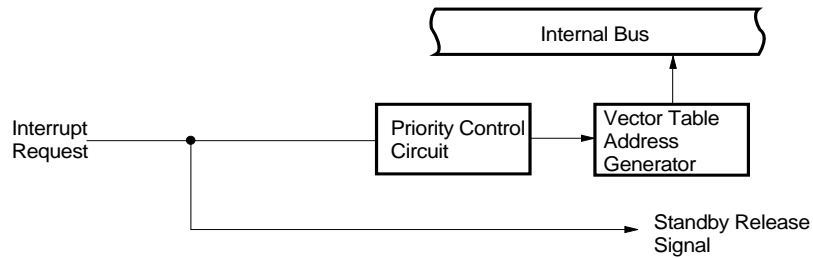

(B) Internal Maskable Interrupt

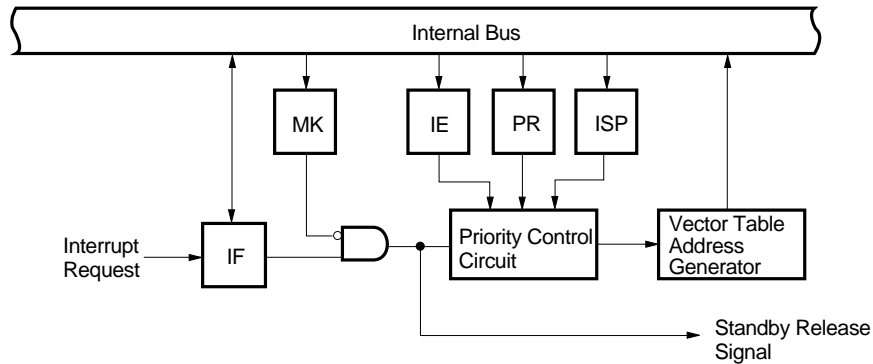

(C) External Maskable Interrupt (INTP0)

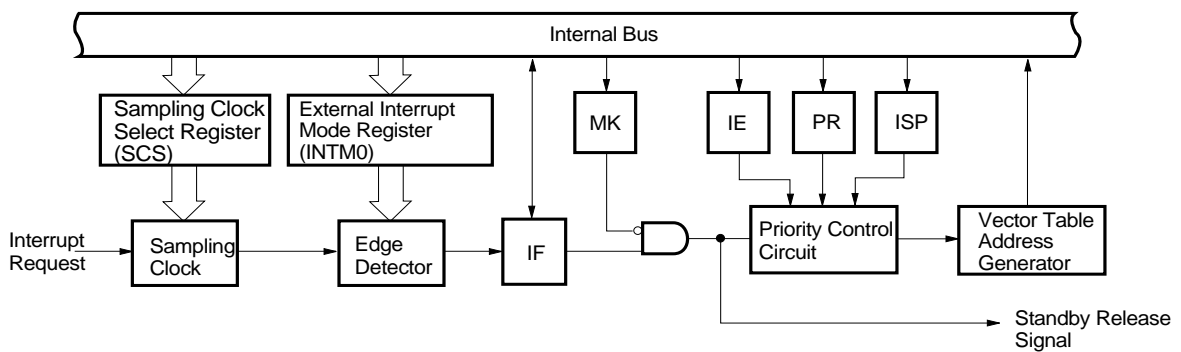
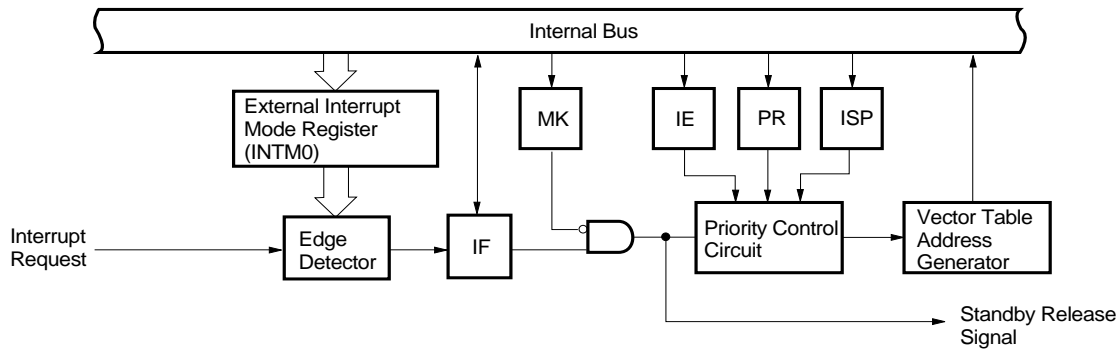
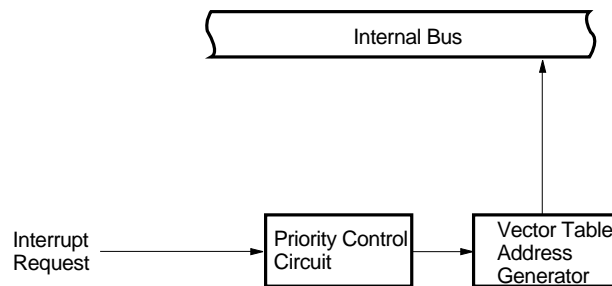

Figure 6-1. Basic Interrupt Function Configuration (2/2)

(D) External Maskable Interrupt (Except INTP0)



(E) Software Interrupt



- IF : Interrupt request flag
- IE : Interrupt enable flag
- ISP : In-service priority flag
- MK : Interrupt mask flag
- PR : Priority specification flag

6.2 TEST FUNCTIONS

There are two test functions as shown in Table 6-2.

Table 6-2. Test Source List

Test Source		Internal/External
Name	Trigger	
INTWT	Watch timer overflow	Internal
INTPT4	Port 4 falling edge detection	External

Figure 6-2. Test Function Basic Configuration

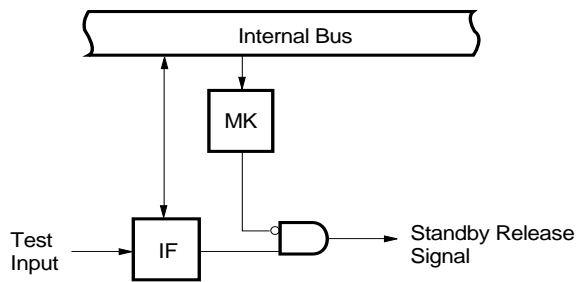

IF : Test input flag
 MK : Test mask flag

7. EXTERNAL DEVICE EXPANSION FUNCTIONS

The external device expansion function is used to connect external devices to areas other than the internal ROM, RAM and SFR.

Ports 4 to 6 are used for connection with external devices.

8. STANDBY FUNCTIONS

There are the following two standby functions to reduce the current dissipation.

- HALT mode : The CPU operating clock is stopped. The average consumption current can be reduced by intermittent operation in combination with the normal operating mode.
- STOP mode : The main system clock oscillation is stopped. The whole operation by the main system clock is stopped, so that the system operates with ultra-low power consumption using only the subsystem clock.

Figure 8-1. Standby Functions

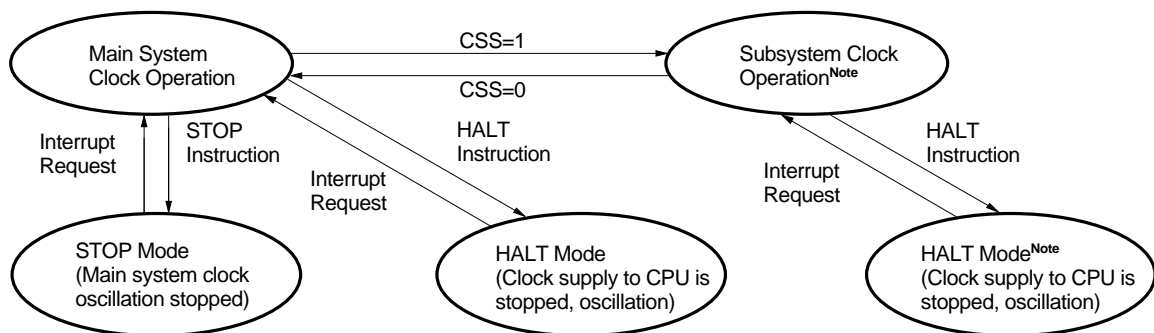

Note The power consumption can be reduced by stopping the main system clock. When the CPU is operating on the subsystem clock, set the MCC to stop the main system clock. The STOP instruction cannot be used.

Caution When the main system clock is stopped and the system is operated by the subsystem clock, the subsystem clock should be switched again to the main system clock after the oscillation stabilization time is secured by the program by the program.

9. RESET FUNCTIONS

There are the following two reset methods.

- External reset input by $\overline{\text{RESET}}$ pin.
- Internal reset by watchdog timer runaway time detection.

10. INSTRUCTION SET

(1) 8-Bit Instruction

MOV, XCH, ADD, ADDC, SUB, SUBC, AND, OR, XOR, CMP, MULU, DIVUW, INC, DEC, ROR, ROL, RORC, ROLC, ROR4, ROL4, PUSH, POP, DBNZ

2nd Operand 1st Operand	#byte	A	r Note	sfr	saddr	!addr16	PSW	[DE]	[HL]	[HL+byte] [HL+B] [HL+C]	\$addr16	1	None
A	ADD ADDC SUB SUBC AND OR XOR CMP		MOV XCH ADD ADDC SUB SUBC AND OR XOR CMP	MOV XCH	MOV XCH ADD ADDC SUB SUBC AND OR XOR CMP	MOV XCH ADD ADDC SUB SUBC AND OR XOR CMP	MOV	MOV XCH	MOV XCH ADD ADDC SUB SUBC AND OR XOR CMP	MOV XCH ADD ADDC SUB SUBC AND OR XOR CMP		ROR ROL RORC ROLC	
r	MOV	MOV ADD ADDC SUB SUBC AND OR XOR CMP											INC DEC
r1											DBNZ		
sfr	MOV	MOV											
saddr	MOV ADD ADDC SUB SUBC AND OR XOR CMP	MOV									DBNZ		INC DEC
!addr16		MOV											
PSW	MOV	MOV											PUSH POP
[DE]		MOV											
[HL]		MOV											ROR4 ROL4
[HL+byte] [HL+B] [HL+C]		MOV											
X													MULU
C													DIVUW

Note Except r=A

(2) 16-Bit Instruction

MOVW, XCHW ADDW, SUBW, CMPW, PUSH, POP, INCW, DECW

2nd Operand 1st Operand	#byte	AX	rp ^{Note}	saddrp	!addr16	SP	None	
AX	ADDW SUBW CMPW		MOVW XCHW	MOVW	MOVW	MOVW	MOVW	
rp	MOVW	MOVW ^{Note}						INCW, DECW PUSH, POP
sfrp	MOVW	MOVW						
saddrp	MOVW	MOVW						
!addr16		MOVW						
SP	MOVW	MOVW						

Note Only when rp=BC, DE, HL.

(3) Bit Manipulation Instruction

MOV1, AND1, OR1, XOR1, SET1, CLR1, NOT1, BT, BF, BTCLR

2nd Operand 1st Operand	A.bit	sfr.bit	saddr.bit	PWS.bit	[HL].bit	CY	\$addr16	None
A.bit						MOV1	BT BF BTCLR	SET1 CLR1
sfr.bit						MOV1	BT BF BTCLR	SET1 CLR1
saddr.bit						MOV1	BT BF BTCLR	SET1 CLR1
PSW.bit						MOV1	BT BF BTCLR	SET1 CLR1
[HL].bit						MOV1	BT BF BTCLR	SET1 CLR1
CY	MOV1 AND1 OR1 XOR1	MOV1 AND1 OR1 XOR1	MOV1 AND1 OR1 XOR1	MOV1 AND1 OR1 XOR1	MOV1 AND1 OR1 XOR1			SET1 CLR1 NOT1

(4) Call Instruction/Branch Instruction

CALL, CALLF, CALLT, BR, BC, BNC, BZ, BNZ, BT, BF, BTCLR, DBNZ

2nd Operand 1st Operand	AX	!addr16	!addr11	[addr5]	\$addr16
Basic instruction	BR	CALL, BR	CALLF	CALLT	BR, BC, BNC, BZ, BNZ
Compound instruction					BT, BF, BTCLR, DBNZ

(5) Other Instruction

ADJBA, ADJBS, BRK, RET, RETI, RETB, SEL, NOP, EI, DI, HALT, STOP

11. ELECTRICAL SPECIFICATIONS

Absolute Maximum Ratings (T_A = 25 °C)

Parameter	Symbol	Test Conditions		Rating	Unit
Supply voltage	V _{DD}			-0.3 to + 7.0	V
	AV _{DD}			-0.3 to V _{DD} + 0.3	V
	AV _{REF}			-0.3 to V _{DD} + 0.3	V
	AV _{SS}			-0.3 to + 0.3	V
Input voltage	V _{I1}	P00 to P04, P10 to P17, P20 to P27, P30 to P37 P40 to P47, P50 to P57, P64 to P67, X1, X2, XT2		-0.3 to V _{DD} + 0.3	V
	V _{I2}	P60 to P67	Open-drain	-0.3 to +16	V
Output voltage	V _O			-0.3 to V _{DD} + 0.3	V
Analog input voltage	V _{AN}	P10 to P17	Analog input pin	AV _{SS} -0.3 to AV _{REF} + 0.3	V
Output current high	I _{OH}	1 pin		-10	mA
		P10 to P17, P20 to P27, P30 to P37 total		-15	mA
		P01 to P03, P40 to P47, P50 to P57, P60 to P67 total		-15	mA
Output current low	I _{OL} Note	1 pin	Peak value	30	mA
			rms	15	mA
		P40 to P47, P50 to P55 total	Peak value	100	mA
			rms	70	mA
		P01 to P03, P56, P57, P60 to P67 total	Peak value	100	mA
			rms	70	mA
		P01 to P03, P64 to P67 total	Peak value	50	mA
			rms	20	mA
		P10 to P17, P20 to P27, P30 to P37 total	Peak value	50	mA
			rms	20	mA
Operating ambient temperature	T _A			-40 to +85	°C
Storage temperature	T _{stg}			-65 to +150	°C

Note rms should be calculated as follows: [rms] = [peak value] × √duty

Caution Product quality may suffer if the absolute maximum rating is exceeded for even a single parameter or even momentarily. That is, the absolute maximum ratings are rated values at which the product is on the verge of suffering physical damage, and therefore the product must be used under conditions which ensure that the absolute maximum ratings are not exceeded.

Capacitance ($T_A = 25\text{ }^\circ\text{C}$, $V_{DD} = V_{SS} = 0\text{ V}$)

Parameter	Symbol	Test Conditions	MIN.	TYP.	MAX.	Unit	
Input capacitance	C_{IN}	$f = 1\text{ MHz}$ Unmeasured pins returned to 0 V			15	pF	
I/O capacitance	C_{IO}	$f = 1\text{ MHz}$ Unmeasured pins returned to 0 V	P01 to P03, P10 to P17, P20 to P27, P30 to P37, P40 to P47, P50 to P57, P64 to P67			15	pF
			P60 to P63			20	pF

Remark The characteristics of a dual-function pin and a port pin are the same unless specified otherwise.

Main System Clock Oscillation Circuit Characteristics ($T_A = -40\text{ to }+85\text{ }^\circ\text{C}$, $V_{DD} = 1.8\text{ to }5.5\text{ V}$)

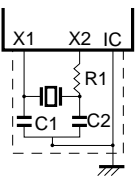
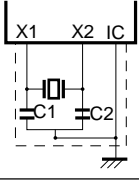
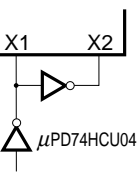
Resonator	Recommended Circuit	Parameter	Test Conditions	MIN.	TYP.	MAX.	Unit
Ceramic resonator		Oscillator frequency (f_x) Note 1	$2.7\text{ V} \leq V_{DD} \leq 5.5\text{ V}$	1		10	MHz
			$1.8\text{ V} \leq V_{DD} < 2.7\text{ V}$	1		5	
		Oscillation stabilization time Note 2	After V_{DD} reaches oscillator voltage range MIN.			4	ms
Crystal resonator		Oscillator frequency (f_x) Note 1	$2.7\text{ V} \leq V_{DD} \leq 5.5\text{ V}$	1		10	MHz
			$1.8\text{ V} \leq V_{DD} < 2.7\text{ V}$	1		5	
		Oscillation stabilization time Note 2	$V_{DD} = 4.5\text{ to }5.5\text{ V}$			10	ms
						30	
External clock		X1 input frequency (f_x) Note 1		1.0		10.0	MHz
		X1 input high/low level width (t_{xH} , t_{xL})		45		500	ns

Notes 1. Indicates only oscillation circuit characteristics. Refer to **AC Characteristics** for instruction execution time.

2. Time required to stabilize oscillation after reset or STOP mode release.

Cautions 1. When using the main system clock oscillator, wiring in the area enclosed with the dotted line should be carried out as follows to avoid an adverse effect from wiring capacitance.

- Wiring should be as short as possible.
- Wiring should not cross other signal lines.
- Wiring should not be placed close to a varying high current.
- The potential of the oscillator capacitor ground should be the same as V_{SS} .
- Do not ground wiring to a ground pattern in which a high current flows.
- Do not fetch a signal from the oscillator.

2. When the main system clock is stopped and the system is operated by the subsystem clock, the subsystem clock should be switched again to the main system clock after the oscillation stabilization time is secured by the program.

Subsystem Clock Oscillation Circuit Characteristics ($T_A = -40$ to $+85$ °C, $V_{DD} = 1.8$ to 5.5 V)

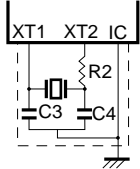
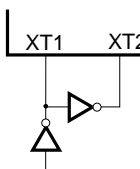
Resonator	Recommended Circuit	Parameter	Test Conditions	MIN.	TYP.	MAX.	Unit
Crystal resonator		Oscillator frequency (f_{XT}) Note 1		32	32.768	35	kHz
		Oscillation stabilization time Note 2	$V_{DD} = 4.5$ to 5.5 V		1.2	2	s
External clock		XT1 input frequency (f_{XT}) Note 1		32		100	
		XT1 input high/low level width (t_{XTH} , t_{XTL})		5		15	μs

Notes 1. Indicates only oscillation circuit characteristics. Refer to **AC Characteristics** for instruction execution time.

2. Time required to stabilize oscillation after V_{DD} reaches oscillator voltage MIN.

Cautions 1. When using the subsystem clock oscillator, wiring in the area enclosed with the dotted line should be carried out as follows to avoid an adverse effect from wiring capacitance.

- Wiring should be as short as possible.
- Wiring should not cross other signal lines.
- Wiring should not be placed close to a varying high current.
- The potential of the oscillator capacitor ground should be the same as V_{SS} .
- Do not ground wiring to a ground pattern in which a high current flows.
- Do not fetch a signal from the oscillator.

2. The subsystem clock oscillation circuit is a circuit with a low amplification level, more prone to misoperation due to noise than the main system clock.

Particular care is therefore required with the wiring method when the subsystem clock is used.

DC Characteristics ($T_A = -40$ to $+85$ °C, $V_{DD} = 1.8$ to 5.5 V)

Parameter	Symbol	Test Conditions	MIN.	TYP.	MAX.	Unit	
Input voltage high	V _{IH1}	P10-P17, P21, P23, P30-P32, P35-P37, P40-P47, P50-P57, P64-67	V _{DD} = 2.7 to 5.5 V	0.7 V _{DD}		V _{DD}	V
				0.8 V _{DD}		V _{DD}	V
	V _{IH2}	P00-P03, P20, P22, P24-P27, P33, P34, $\overline{\text{RESET}}$	V _{DD} = 2.7 to 5.5 V	0.8 V _{DD}		V _{DD}	V
				0.85 V _{DD}		V _{DD}	V
	V _{IH3}	P60-P63 (N-ch open-drain)	V _{DD} = 2.7 to 5.5 V	0.7 V _{DD}		15	V
				0.8 V _{DD}		15	V
	V _{IH4}	X1, X2	V _{DD} = 2.7 to 5.5 V	V _{DD} - 0.5		V _{DD}	V
				V _{DD} - 0.2		V _{DD}	V
	V _{IH5}	XT1/P04, XT2	4.5 V ≤ V _{DD} ≤ 5.5 V	0.8 V _{DD}		V _{DD}	V
			2.7 V ≤ V _{DD} < 4.5 V	0.9 V _{DD}		V _{DD}	V
1.8 V ≤ V _{DD} < 2.7 V Note			0.9 V _{DD}		V _{DD}	V	
Input voltage low	V _{IL1}	P10-P17, P21, P23, P30-P32, P35-P37, P40-P47, P50-P57, P64-67	V _{DD} = 2.7 to 5.5 V	0		0.3 V _{DD}	V
				0		0.2 V _{DD}	V
	V _{IL2}	P00-P03, P20, P22, P24-P27, P33, P34, $\overline{\text{RESET}}$	V _{DD} = 2.7 to 5.5 V	0		0.2 V _{DD}	V
				0		0.15 V _{DD}	V
	V _{IL3}	P60-P63	4.5 V ≤ V _{DD} ≤ 5.5 V	0		0.3 V _{DD}	V
			2.7 V ≤ V _{DD} < 4.5 V	0		0.2 V _{DD}	V
				0		0.1 V _{DD}	V
	V _{IL4}	X1, X2	V _{DD} = 2.7 to 5.5 V	0		0.4	V
				0		0.2	V
	V _{IL5}	XT1/P04, XT2	4.5 V ≤ V _{DD} ≤ 5.5 V	0		0.2 V _{DD}	V
2.7 V ≤ V _{DD} < 4.5 V			0		0.1 V _{DD}	V	
1.8 V ≤ V _{DD} < 2.7 V Note			0		0.1 V _{DD}	V	
Output voltage high	V _{OH1}	V _{DD} = 4.5 to 5.5 V, I _{OH} = -1 mA	V _{DD} - 1.0			V	
		I _{OH} = -100 μA	V _{DD} - 0.5			V	
Output voltage low	V _{OL1}	P50 to P57, P60 to P63	V _{DD} = 4.5 to 5.5 V, I _{OL} = 15 mA		0.4	2.0	V
		P01 to P03, P10 to P17, P20 to P27 P30 to P37, P40 to P47, P64 to P67	V _{DD} = 4.5 to 5.5 V, I _{OL} = 1.6 mA			0.4	V
	V _{OL2}	SB0, SB1, $\overline{\text{SCK0}}$	V _{DD} = 4.5 to 5.5 V, open-drain pulled-up (R = 1 KΩ)			0.2 V _{DD}	V
	V _{OL3}	I _{OL} = 400 μA				0.5	V

Note When using XT1/P04 as P04, input the inverse of P04 to XT2 using an inverter.

Remark The characteristics of a dual-function pin and a port pin are the same unless specified otherwise.

DC Characteristics ($T_A = -40$ to $+85$ °C, $V_{DD} = 1.8$ to 5.5 V)

Parameter	Symbol	Test Conditions	MIN.	TYP.	MAX.	Unit			
Input leakage current high	I _{LIH1}	$V_{IN} = V_{DD}$			3	μA			
	I _{LIH2}						X1, X2, XT1/P04, XT2	20	μA
	I _{LIH3}	$V_{IN} = 15$ V			80	μA			
Input leakage current low	I _{LIL1}	$V_{IN} = 0$ V			-3	μA			
	I _{LIL2}						X1, X2, XT1/P04, XT2	-20	μA
	I _{LIL3}						P60 to P63	-3	Note
Output leakage current high	I _{LOH1}	$V_{OUT} = V_{DD}$			3	μA			
Output leakage current low	I _{LOL}	$V_{OUT} = 0$ V			-3	μA			
Mask option pull-up resistor	R1	$V_{IN} = 0$ V, P60 to P63	20	40	90	kΩ			
Software pull-up resistor	R2	$V_{IN} = 0$ V, P01 to P03, P10 to P17, P20 to P27, P30 to P37, P40 to P47, P50 to P57, P60 to P67	15	40	90	kΩ			

Note For P60-P63, if pull-up resistor is not provided (specifiable by mask option) a low-level input leak current of -200 μA (MAX.) flows only during the 3 clocks (no-wait time) after an instruction has been executed to read out port 6 (P6) or port mode register 6 (PM6). Outside the period of 3 clocks following execution a read-out instruction, the current is -3 μA (MAX.).

Remark The characteristics of a dual-function pin and a port pin are the same unless specified otherwise.

DC Characteristics ($T_A = -40$ to $+85$ °C, $V_{DD} = 1.8$ to 5.5 V)

Parameter	Symbol	Test Conditions	MIN.	TYP.	MAX.	Unit	
Supply current Note 1	I _{DD1}	10.00 MHz crystal oscillation operation mode	$V_{DD} = 5.0\text{ V} \pm 10\%$ Note 2		9.0	18.0	mA
			$V_{DD} = 3.0\text{ V} \pm 10\%$ Note 3		1.3	2.6	mA
	I _{DD2}	10.00 MHz crystal oscillation HALT mode	$V_{DD} = 5.0\text{ V} \pm 10\%$ Note 2		2.0	4.0	mA
			$V_{DD} = 3.0\text{ V} \pm 10\%$ Note 3		1.0	2.0	mA
	I _{DD3}	32.768 kHz crystal oscillation operation mode Note 4	$V_{DD} = 5.0\text{ V} \pm 10\%$ Note 3		60	120	μA
			$V_{DD} = 3.0\text{ V} \pm 10\%$ Note 3		35	70	μA
			$V_{DD} = 2.0\text{ V} \pm 10\%$ Note 4		24	48	μA
	I _{DD4}	32.768 kHz crystal oscillation HALT mode	$V_{DD} = 5.0\text{ V} \pm 10\%$ Note 3		25	50	μA
			$V_{DD} = 3.0\text{ V} \pm 10\%$ Note 3		5	15	μA
			$V_{DD} = 2.0\text{ V} \pm 10\%$ Note 4		2	10	μA
	I _{DD5}	XT1 = V_{DD} STOP mode when using feedback resistor	$V_{DD} = 5.0\text{ V} \pm 10\%$		1	30	μA
			$V_{DD} = 3.0\text{ V} \pm 10\%$		0.5	10	μA
$V_{DD} = 2.0\text{ V} \pm 10\%$ Note 4				0.3	10	μA	
I _{DD6}	XT1 = V_{DD} STOP mode when not using feedback resistor	$V_{DD} = 5.0\text{ V} \pm 10\%$		0.1	30	μA	
		$V_{DD} = 3.0\text{ V} \pm 10\%$		0.05	10	μA	
		$V_{DD} = 2.0\text{ V} \pm 10\%$ Note 4		0.05	10	μA	

Notes 1. Current flowing into the V_{DD} and AV_{DD} pins. However, the current flowing into the A/D converter and internal pull-up resistors is not included.

- 2.** When operating at high-speed mode (when the processor clock control register (PCC) is set to 00H)
- 3.** When operating at low-speed mode (when the PCC is set to 04H)
- 4.** When main system clock stopped.

AC Characteristics

(1) Basic Operation ($T_A = -40$ to $+85$ °C, $V_{DD} = 1.8$ to 5.5 V)

Parameter	Symbol	Test Conditions		MIN.	TYP.	MAX.	Unit
Cycle time (Min. instruction execution time)	T_{CY}	Operating on main system clock	$3.5\text{ V} \leq V_{DD} \leq 5.5\text{ V}$	0.4		64	μs
			$2.7\text{ V} \leq V_{DD} < 3.5\text{ V}$	0.8		64	μs
			$1.8\text{ V} \leq V_{DD} < 2.7\text{ V}$	2.0		64	μs
		Operating on subsystem clock		40	122	125	μs
TI0 input frequency	t_{TIH0}	$3.5\text{ V} \leq V_{DD} \leq 5.5\text{ V}$		$2/f_{sam}+0.1$ Note			μs
	t_{TIL0}	$2.7\text{ V} \leq V_{DD} < 3.5\text{ V}$		$2/f_{sam}+0.2$ Note			μs
		$1.8\text{ V} \leq V_{DD} < 2.7\text{ V}$		$2/f_{sam}+0.5$ Note			μs
TI1, TI2 input frequency	f_{TI1}	$V_{DD} = 4.5$ to 5.5 V		0		4	MHz
				0		275	kHz
TI1, TI2 input high/low-level width	t_{TIH1}	$V_{DD} = 4.5$ to 5.5 V		100			ns
	t_{TIL1}			1.8			μs
Interrupt input high/low-level width	t_{INTH}	INTP0	$3.5\text{ V} \leq V_{DD} \leq 5.5\text{ V}$	$2/f_{sam}+0.1$ Note			μs
			$2.7\text{ V} \leq V_{DD} < 3.5\text{ V}$	$2/f_{sam}+0.2$ Note			μs
			$1.8\text{ V} \leq V_{DD} < 2.7\text{ V}$	$2/f_{sam}+0.5$ Note			μs
	t_{INTL}	INTP1-INTP3, KR0-KR7	$V_{DD} = 2.7$ to 5.5 V	10			μs
				20			μs
RESET low level width	t_{RSL}	$V_{DD} = 2.7$ to 5.5 V		10			μs
				20			μs

Note In combination with bits 0 (SCS0) and 1 (SCS1) of sampling clock select register, selection of f_{sam} is possible between $f_X/2^{N+1}$, $f_X/64$ and $f_X/128$ (when $N=0$ to 4).

T_{CY} vs V_{DD} (At main system clock operation)

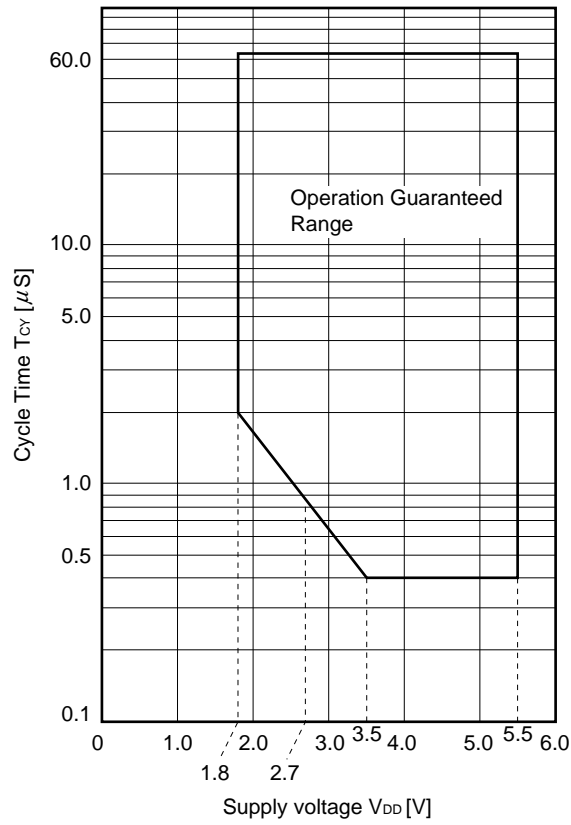

(2) Read/Write Operation ($T_A = -40$ to $+85$ °C, $V_{DD} = 2.7$ to 5.5 V)

Parameter	Symbol	Test Conditions	MIN.	MAX.	Unit
ASTB high-level width	t _{ASTH}		0.5t _{cy}		ns
Address setup time	t _{ADS}		0.5t _{cy} -30		ns
Address hold time	t _{ADH}		50		ns
Data input time from address	t _{ADD1}			(2.5+2n)t _{cy} -50	ns
	t _{ADD2}			(3+2n)t _{cy} -100	ns
Data input time from $\overline{RD}\downarrow$	t _{rDD1}			(1+2n)t _{cy} -25	ns
	t _{rDD2}			(2.5+2n)t _{cy} -100	ns
Read data hold time	t _{RDH}		0		ns
\overline{RD} low-level width	t _{rDL1}		(1.5+2n)t _{cy} -20		ns
	t _{rDL2}		(2.5+2n) t _{cy} -20		ns
$\overline{WAIT}\downarrow$ input time from $\overline{RD}\downarrow$	t _{rDWT1}			0.5t _{cy}	ns
	t _{rDWT2}			1.5t _{cy}	ns
$\overline{WAIT}\downarrow$ input time from $\overline{WR}\downarrow$	t _{rRWT}			0.5t _{cy}	ns
\overline{WAIT} low-level width	t _{WTL}		(0.5+2n)t _{cy} +10	(2+2n)t _{cy}	ns
Write data setup time	t _{WDS}		100		ns
Write data hold time	t _{WDH}	Load resistor ≥ 5 kΩ	20		ns
\overline{WR} low-level width	t _{WRL1}		(2.5+2n) t _{cy} -20		ns
$\overline{RD}\downarrow$ delay time from $\overline{ASTB}\downarrow$	t _{ASTRD}		0.5t _{cy} -30		ns
$\overline{WR}\downarrow$ delay time from $\overline{ASTB}\downarrow$	t _{ASTWR}		1.5t _{cy} -30		ns
ASTB↑ delay time from RD↑ in external fetch	t _{RDAST}		t _{cy} -10	t _{cy} +40	ns
Address hold time from $\overline{RD}\uparrow$ in external fetch	t _{RDADH}		t _{cy}	t _{cy} +50	ns
Write data output time from $\overline{RD}\uparrow$	t _{rDWD}	V _{DD} = 4.5 to 5.5 V	0.5t _{cy} +5	0.5t _{cy} +30	ns
			0.5t _{cy} +15	0.5t _{cy} +90	ns
Write data output time from $\overline{WR}\downarrow$	t _{rRWD}	V _{DD} = 4.5 to 5.5 V	5	30	ns
			15	90	ns
Address hold time from $\overline{WR}\uparrow$	t _{WRADH}	V _{DD} = 4.5 to 5.5 V	t _{cy}	t _{cy} +60	ns
			t _{cy}	t _{cy} +100	ns
$\overline{RD}\uparrow$ delay time from $\overline{WAIT}\uparrow$	t _{WTRD}		0.5t _{cy}	2.5t _{cy} +80	ns
$\overline{WR}\uparrow$ delay time from $\overline{WAIT}\uparrow$	t _{WTWR}		0.5t _{cy}	2.5t _{cy} +80	ns

- Remarks**
1. t_{cy} = T_{cy}/4
 2. n indicates number of waits.

(3) Serial Interface (T_A = -40 to +85 °C, V_{DD} = 1.8 to 5.5 V)

(a) Serial Interface Channel 0

(i) 3-wire serial I/O mode ($\overline{\text{SCK0}}$... Internal clock output)

Parameter	Symbol	Conditions	MIN.	TYP.	MAX.	Unit
$\overline{\text{SCK0}}$ cycle time	t _{KCY1}	4.5 V ≤ V _{DD} ≤ 5.5 V	800			ns
		2.7 V ≤ V _{DD} < 4.5 V	1600			ns
		2.0 V ≤ V _{DD} < 2.7 V	3200			ns
			4800			ns
$\overline{\text{SCK0}}$ high/low-level width	t _{KH1}	V _{DD} = 4.5 to 5.5 V	t _{KCY1} /2-50			ns
	t _{KL1}		t _{KCY1} /2-100			ns
SIO setup time (to $\overline{\text{SCK0}}\uparrow$)	t _{SIK1}	4.5 V ≤ V _{DD} ≤ 5.5 V	100			ns
		2.7 V ≤ V _{DD} < 4.5 V	150			ns
		2.0 V ≤ V _{DD} < 2.7 V	300			ns
			400			ns
SIO hold time (from $\overline{\text{SCK0}}\uparrow$)	t _{KS1}		400			ns
SO0 output delay time from $\overline{\text{SCK0}}\downarrow$	t _{KSO1}	C = 100 pF Note			300	ns

Note C is the load capacitance of $\overline{\text{SCK0}}$ and SO0 output line.

(ii) 3-wire serial I/O mode ($\overline{\text{SCK0}}$... External clock input)

Parameter	Symbol	Test Conditions	MIN.	TYP.	MAX.	Unit
$\overline{\text{SCK0}}$ cycle time	t _{KCY2}	4.5 V ≤ V _{DD} ≤ 5.5 V	800			ns
		2.7 V ≤ V _{DD} < 4.5 V	1600			ns
		2.0 V ≤ V _{DD} < 2.7 V	3200			ns
			4800			ns
$\overline{\text{SCK0}}$ high/low-level width	t _{KH2}	4.5 V ≤ V _{DD} ≤ 5.5 V	400			ns
		2.7 V ≤ V _{DD} < 4.5 V	800			ns
	t _{KL2}	2.0 V ≤ V _{DD} < 2.7 V	1600			ns
			2400			ns
SIO setup time (to $\overline{\text{SCK0}}\uparrow$)	t _{SIK2}	V _{DD} = 2.0 to 5.5 V	100			ns
			150			ns
SIO hold time (from $\overline{\text{SCK0}}\uparrow$)	t _{KS2}		400			ns
SO0 output delay time from $\overline{\text{SCK0}}\downarrow$	t _{KSO2}	C = 100 pF Note	V _{DD} = 2.0 to 5.5 V		300	ns
					500	ns
$\overline{\text{SCK0}}$ rise, fall time	t _{r2} t _{f2}	When external device expansion function is used			160	ns
		When external device expansion function is not used	When 16-bit timer output function is used		700	ns
			When 16-bit timer output function is not used		1000	ns

Note C is the load capacitance of SO0 output line.

(iii) SBI mode ($\overline{\text{SCK0}}$... Internal clock output)

Parameter	Symbol	Test Conditions		MIN.	TYP.	MAX.	Unit
$\overline{\text{SCK0}}$ cycle time	t_{KCY3}	$4.5 \text{ V} \leq V_{\text{DD}} \leq 5.5 \text{ V}$		800			ns
		$2.0 \text{ V} \leq V_{\text{DD}} < 4.5 \text{ V}$		3200			ns
				4800			ns
$\overline{\text{SCK0}}$ high/low-level width	t_{KH3}	$V_{\text{DD}} = 4.5 \text{ to } 6.0 \text{ V}$		$t_{\text{KCY3}}/2-50$			ns
	t_{KL3}			$t_{\text{KCY3}}/2-150$			ns
SB0, SB1 setup time (to $\overline{\text{SCK0}}\uparrow$)	t_{SIK3}	$4.5 \text{ V} \leq V_{\text{DD}} \leq 5.5 \text{ V}$		100			ns
		$2.0 \text{ V} \leq V_{\text{DD}} < 4.5 \text{ V}$		300			ns
				400			ns
SB0, SB1 hold time (from $\overline{\text{SCK0}}\uparrow$)	t_{KS13}			$t_{\text{KCY3}}/2$			ns
SB0, SB1 output delay time from $\overline{\text{SCK0}}\downarrow$	t_{KSO3}	R = 1 kΩ, C = 100 pF Note	$V_{\text{DD}} = 4.5 \text{ to } 5.5 \text{ V}$	0		250	ns
				0		1000	ns
SB0, SB1 \downarrow from $\overline{\text{SCK0}}\uparrow$	t_{KSB}			t_{KCY3}			ns
$\overline{\text{SCK0}}\downarrow$ from SB0, SB1 \downarrow	t_{SBK}			t_{KCY3}			ns
SB0, SB1 high-level width	t_{SBH}			t_{KCY3}			ns
SB0, SB1 low-level width	t_{SBL}			t_{KCY3}			ns

Note R and C are the load resistors and load capacitance of the SB0, SB1 and $\overline{\text{SCK0}}$ output line.

(iv) SBI mode (SCK0... External clock input)

Parameter	Symbol	Test Conditions		MIN.	TYP.	MAX.	Unit
SCK0 cycle time	t _{KCY4}	4.5 V ≤ V _{DD} ≤ 5.5 V		800			ns
		2.0 V ≤ V _{DD} < 4.5 V		3200			ns
				4800			ns
SCK0 high/low-level width	t _{KH4}	4.5 V ≤ V _{DD} ≤ 5.5 V		400			ns
	t _{KL4}	2.0 V ≤ V _{DD} < 4.5 V		1600			ns
				2400			ns
SB0, SB1 setup time (to SCK0↑)	t _{SIK4}	4.5 V ≤ V _{DD} ≤ 5.5 V		100			ns
		2.0 V ≤ V _{DD} < 4.5 V		300			ns
				400			ns
SB0, SB1 hold time (from SCK0↑)	t _{KSI4}			t _{KCY4} /2			ns
SB0, SB1 output delay time from SCK0↓	t _{KSO4}	R = 1 kΩ, C = 100 pF Note	V _{DD} = 4.5 to 5.5 V	0		300	ns
				0		1000	ns
SB0, SB1↓ from SCK0↑	t _{KSB}			t _{KCY4}			ns
SCK0↓ from SB0, SB1↓	t _{SBK}			t _{KCY4}			ns
SB0, SB1 high-level width	t _{SBH}			t _{KCY4}			ns
SB0, SB1 low-level width	t _{SBL}			t _{KCY4}			ns
SCK0 rise, fall time	t _{R4} t _{F4}	When external device expansion function is used				160	ns
		When external device expansion function is not used	When 16-bit timer output function is used			700	ns
			When 16-bit timer output function is not used			1000	ns

Note R and C are the load resistors and load capacitance of the SB0 and SB1 output line.

(v) 2-wire serial I/O mode ($\overline{\text{SCK0}}$... Internal clock output)

Parameter	Symbol	Test Conditions	MIN.	TYP.	MAX.	Unit	
$\overline{\text{SCK0}}$ cycle time	t_{KCY5}	R = 1 kΩ, C = 100 pF Note	$2.7 \text{ V} \leq V_{\text{DD}} \leq 5.5 \text{ V}$	1600			ns
			$2.0 \text{ V} \leq V_{\text{DD}} < 2.7 \text{ V}$	3200			ns
				4800			ns
$\overline{\text{SCK0}}$ high-level width	t_{KH5}		$V_{\text{DD}} = 2.7 \text{ to } 5.5 \text{ V}$	$t_{\text{KCY5}}/2-160$			ns
				$t_{\text{KCY5}}/2-190$			ns
$\overline{\text{SCK0}}$ low-level width	t_{KL5}		$V_{\text{DD}} = 4.5 \text{ to } 5.5 \text{ V}$	$t_{\text{KCY5}}/2-50$			ns
				$t_{\text{KCY5}}/2-100$			ns
SB0, SB1 setup time (to $\overline{\text{SCK0}}\uparrow$)	t_{SIK5}		$4.5 \text{ V} \leq V_{\text{DD}} \leq 5.5 \text{ V}$	300			ns
			$2.7 \text{ V} \leq V_{\text{DD}} < 4.5 \text{ V}$	350			ns
			$2.0 \text{ V} \leq V_{\text{DD}} < 2.7 \text{ V}$	400			ns
				500			ns
SB0, SB1 hold time (from $\overline{\text{SCK0}}\uparrow$)	t_{KSI5}		600			ns	
SB0, SB1 output delay time from $\overline{\text{SCK0}}\downarrow$	t_{KSO5}		0		300	ns	

Note R and C are the load resistors and load capacitance of the $\overline{\text{SCK0}}$, SB0 and SB1 output line.

(vi) 2-wire serial I/O mode ($\overline{\text{SCK0}}$... External clock input)

Parameter	Symbol	Test Conditions		MIN.	TYP.	MAX.	Unit
$\overline{\text{SCK0}}$ cycle time	t_{CY6}	$2.7 \text{ V} \leq V_{\text{DD}} \leq 5.5 \text{ V}$		1600			ns
		$2.0 \text{ V} \leq V_{\text{DD}} < 2.7 \text{ V}$		3200			ns
				4800			ns
$\overline{\text{SCK0}}$ high-level width	t_{KH6}	$2.7 \text{ V} \leq V_{\text{DD}} \leq 5.5 \text{ V}$		650			ns
		$2.0 \text{ V} \leq V_{\text{DD}} < 2.7 \text{ V}$		1300			ns
				2100			ns
$\overline{\text{SCK0}}$ low-level width	t_{KL6}	$2.7 \text{ V} \leq V_{\text{DD}} \leq 5.5 \text{ V}$		800			ns
		$2.0 \text{ V} \leq V_{\text{DD}} < 2.7 \text{ V}$		1600			ns
				2400			ns
SB0, SB1 setup time (to $\overline{\text{SCK0}}\uparrow$)	t_{SIK6}	$V_{\text{DD}} = 2.0 \text{ to } 5.5 \text{ V}$		100			ns
				150			ns
SB0, SB1 hold time (from $\overline{\text{SCK0}}\uparrow$)	t_{KS16}			$t_{\text{CY6}}/2$			ns
SB0, SB1 output delay time from $\overline{\text{SCK0}}\downarrow$	t_{KSO6}	R = 1 kΩ, C = 100 pF Note	$4.5 \text{ V} \leq V_{\text{DD}} \leq 5.5 \text{ V}$	0		300	ns
			$2.0 \text{ V} \leq V_{\text{DD}} < 4.5 \text{ V}$	0		500	ns
				0		800	ns
$\overline{\text{SCK0}}$ rise, fall time	t_{R6} t_{F6}	When external device expansion function is used				160	ns
		When external device expansion function is not used	When 16-bit timer output function is used			700	ns
			When 16-bit timer output function is not used			1000	ns

Note R and C are the load resistors and load capacitance of the SB0 and SB1 output line.

(b) Serial Interface Channel 1

(i) 3-wire serial I/O mode (SCK1... Internal clock output)

Parameter	Symbol	Test Conditions	MIN.	TYP.	MAX.	Unit
SCK1 cycle time	t _{KCY7}	4.5 V ≤ V _{DD} ≤ 5.5 V	800			ns
		2.7 V ≤ V _{DD} < 4.5 V	1600			ns
		2.0 V ≤ V _{DD} < 2.7 V	3200			ns
			4800			ns
SCK1 high/low-level width	t _{KH7}	V _{DD} = 4.5 to 5.5 V	t _{KCY7} /2–50			ns
	t _{KL7}		t _{KCY7} /2–100			ns
SI1 setup time (to SCK1↑)	t _{SIK7}	4.5 V ≤ V _{DD} ≤ 5.5 V	100			ns
		2.7 V ≤ V _{DD} < 4.5 V	150			ns
		2.0 V ≤ V _{DD} < 2.7 V	300			ns
			400			ns
SI1 hold time (from SCK1↑)	t _{SI7}		400			ns
SO1 output delay time from SCK1↓	t _{KSO7}	C = 100 pF Note			300	ns

Note C is the load capacitance of SCK1 and SO1 output line.

(ii) 3-wire serial I/O mode (SCK1... External clock input)

Parameter	Symbol	Test Conditions	MIN.	TYP.	MAX.	Unit
SCK1 cycle time	t _{KCY8}	4.5 V ≤ V _{DD} ≤ 5.5 V	800			ns
		2.7 V ≤ V _{DD} < 4.5 V	1600			ns
		2.0 V ≤ V _{DD} < 2.7 V	3200			ns
			4800			ns
SCK1 high/low-level width	t _{KH8} t _{KL8}	4.5 V ≤ V _{DD} ≤ 5.5 V	400			ns
		2.7 V ≤ V _{DD} < 4.5 V	800			ns
		2.0 V ≤ V _{DD} < 2.7 V	1600			ns
			2400			ns
SI1 setup time (to SCK1↑)	t _{SIK8}	V _{DD} = 2.0 to 5.5 V	100			ns
			150			ns
SI1 hold time (from SCK1↑)	t _{SI8}		400			ns
SO0 output delay time from SCK1↓	t _{KSO8}	C = 100 pF Note V _{DD} = 2.0 to 5.5 V			300	ns
					500	ns
SCK1 rise, fall time	t _{R8} t _{F8}	When external device expansion function is used			160	ns
		When external device expansion function is not used	When 16-bit timer output function is used		700	ns
			When 16-bit timer output function is not used		1000	ns

Note C is the load capacitance of SO1 output line.

(iii) 3-wire serial I/O mode with automatic transmit/receive function ($\overline{\text{SCK1}}$... Internal clock output)

Parameter	Symbol	Test Conditions	MIN.	TYP.	MAX.	Unit
$\overline{\text{SCK1}}$ cycle time	t_{KCY9}	$4.5 \text{ V} \leq V_{\text{DD}} \leq 5.5 \text{ V}$	800			ns
		$2.7 \text{ V} \leq V_{\text{DD}} < 4.5 \text{ V}$	1600			ns
		$2.0 \text{ V} \leq V_{\text{DD}} < 2.7 \text{ V}$	3200			ns
			4800			ns
$\overline{\text{SCK1}}$ high/low-level width	t_{KH9}	$V_{\text{DD}} = 4.5 \text{ to } 5.5 \text{ V}$	$t_{\text{KCY9}}/2-50$			ns
	t_{KL9}		$t_{\text{KCY9}}/2-100$			ns
SI1 setup time (to $\overline{\text{SCK1}}\uparrow$)	t_{SIK9}	$4.5 \text{ V} \leq V_{\text{DD}} \leq 5.5 \text{ V}$	100			ns
		$2.7 \text{ V} \leq V_{\text{DD}} < 4.5 \text{ V}$	150			ns
		$2.0 \text{ V} \leq V_{\text{DD}} < 2.7 \text{ V}$	300			ns
			400			ns
SI1 hold time (from $\overline{\text{SCK1}}\uparrow$)	t_{KS9}		400			ns
SO1 output delay time from $\overline{\text{SCK1}}\downarrow$	t_{KSO9}	$C = 100 \text{ pF}$ Note			300	ns
STB \uparrow from $\overline{\text{SCK1}}\uparrow$	t_{SBD}		$t_{\text{KCY9}}/2-100$		$t_{\text{KCY9}}/2+100$	ns
Strobe signal high-level width	t_{SBW}	$2.7 \text{ V} \leq V_{\text{DD}} \leq 5.5 \text{ V}$	$t_{\text{KCY9}}-30$		$t_{\text{KCY9}}+30$	ns
		$2.0 \text{ V} \leq V_{\text{DD}} < 2.7 \text{ V}$	$t_{\text{KCY9}}-60$		$t_{\text{KCY9}}+60$	ns
			$t_{\text{KCY9}}-90$		$t_{\text{KCY9}}+90$	ns
Busy signal setup time (to busy signal detection timing)	t_{BYS}		100			ns
Busy signal hold time (from busy signal detection timing)	t_{BYH}	$4.5 \text{ V} \leq V_{\text{DD}} \leq 5.5 \text{ V}$	100			ns
		$2.7 \text{ V} \leq V_{\text{DD}} < 4.5 \text{ V}$	150			ns
		$2.0 \text{ V} \leq V_{\text{DD}} < 2.7 \text{ V}$	200			ns
			300			ns
$\overline{\text{SCK1}}\downarrow$ from busy inactive	t_{SPS}				$2t_{\text{KCY9}}$	ns

Note C is the load capacitance of $\overline{\text{SCK1}}$ and SO1 output line.

(iv) 3-wire serial I/O mode with automatic transmit/receive function ($\overline{\text{SCK1}}$... External clock input)

Parameter	Symbol	Test Conditions	MIN.	TYP.	MAX.	Unit
$\overline{\text{SCK1}}$ cycle time	$t_{\text{KC}Y10}$	$4.5 \text{ V} \leq V_{\text{DD}} \leq 5.5 \text{ V}$	800			ns
		$2.7 \text{ V} \leq V_{\text{DD}} < 4.5 \text{ V}$	1600			ns
		$2.0 \text{ V} \leq V_{\text{DD}} < 2.7 \text{ V}$	3200			ns
			4800			ns
$\overline{\text{SCK1}}$ high/low-level width	$t_{\text{KH}10},$ $t_{\text{KL}10}$	$4.5 \text{ V} \leq V_{\text{DD}} \leq 5.5 \text{ V}$	400			ns
		$2.7 \text{ V} \leq V_{\text{DD}} < 4.5 \text{ V}$	800			ns
		$2.0 \text{ V} \leq V_{\text{DD}} < 2.7 \text{ V}$	1600			ns
			2400			ns
SI1 setup time (to $\overline{\text{SCK1}}\uparrow$)	$t_{\text{SIK}10}$	$V_{\text{DD}} = 2.0 \text{ to } 5.5 \text{ V}$	100			ns
			150			ns
SI1 hold time (from $\overline{\text{SCK1}}\uparrow$)	$t_{\text{KSI}10}$		400			ns
SO1 output delay time from $\overline{\text{SCK1}}\downarrow$	$t_{\text{KSO}10}$	C = 100 pF Note $V_{\text{DD}} = 2.0 \text{ to } 5.5 \text{ V}$			300	ns
					500	ns
$\overline{\text{SCK1}}$ rise, fall time	$t_{\text{R}10}, t_{\text{F}10}$	When external device expansion function is used			160	ns
		When external device expansion function is not used			1000	ns

Note C is the load capacitance of the SO1 output line.

AC Timing Test Point (Excluding X1, XT1 Input)

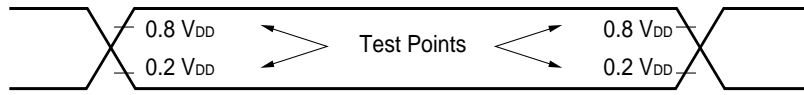

Clock Timing

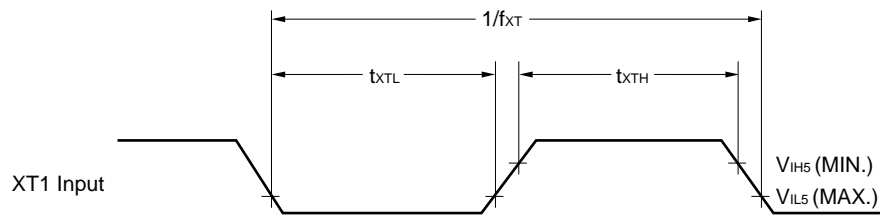
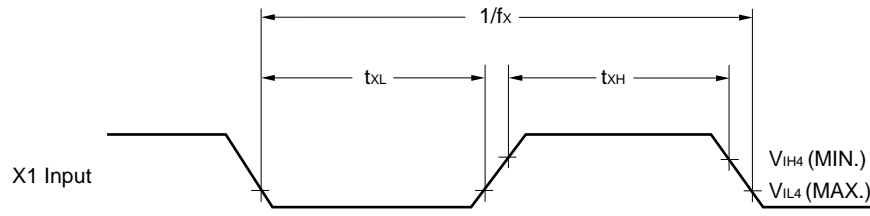

TI Timing

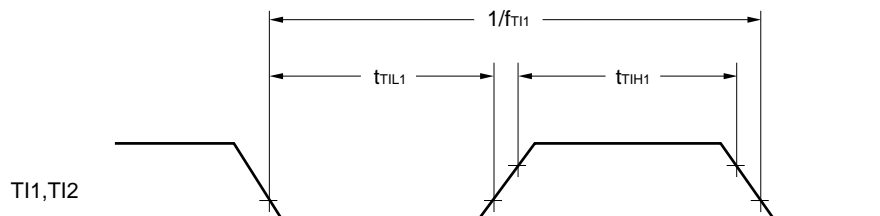
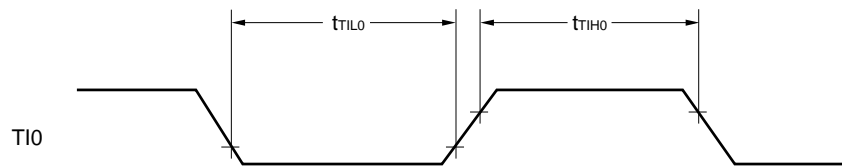

Read/Write Operation

External fetch (No wait):

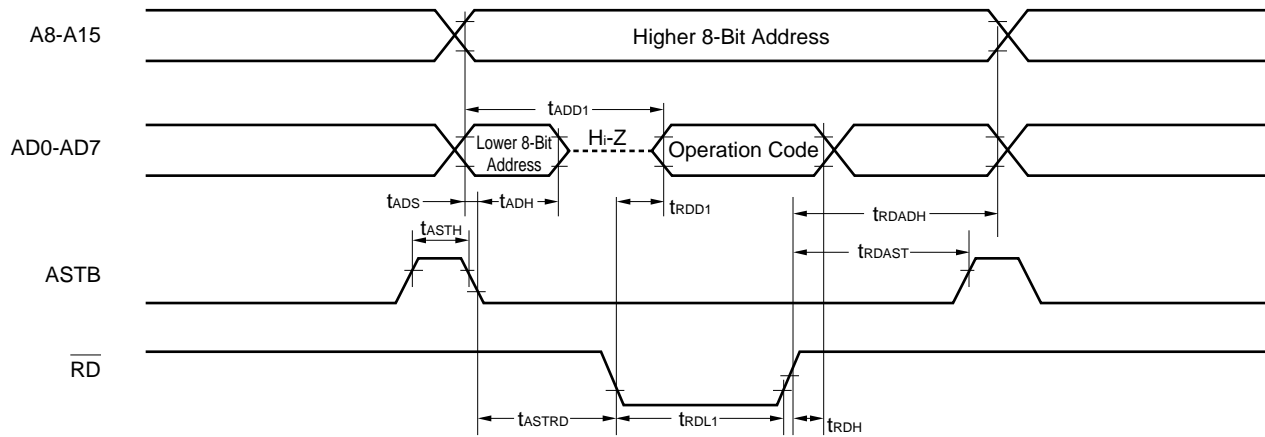

External fetch (Wait insertion):

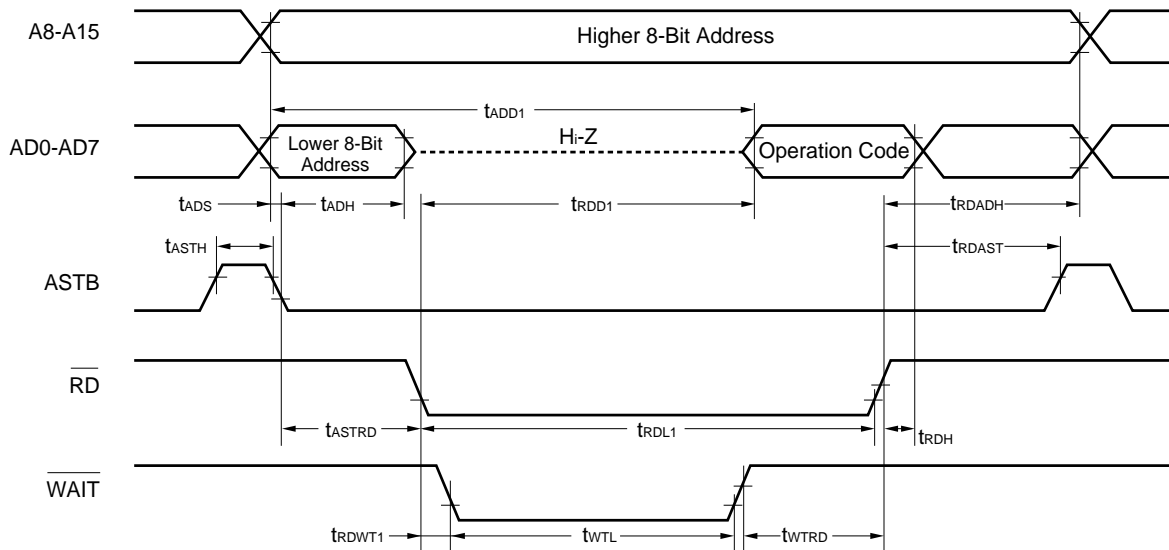

External data access (No wait):

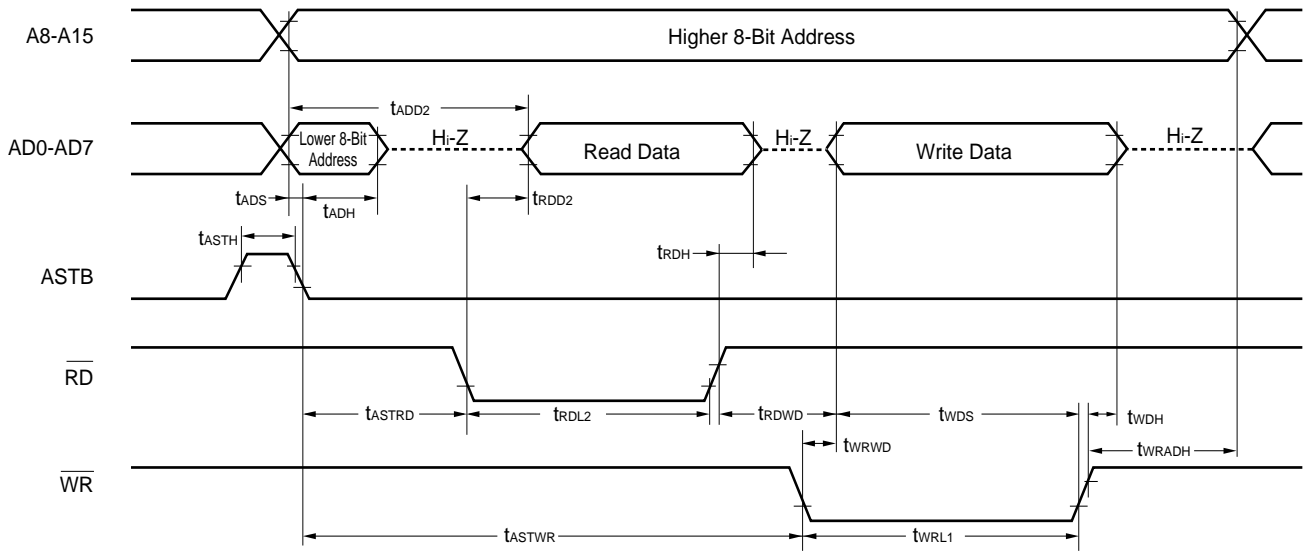

External data access (Wait insertion):

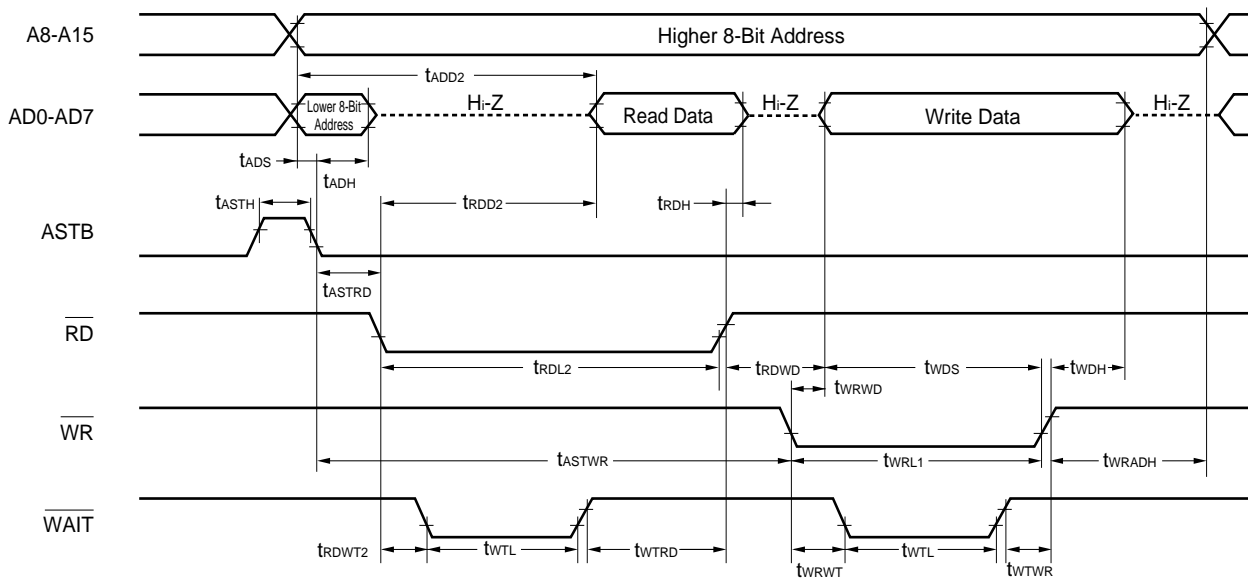

Serial Transfer Timing
3-wire serial I/O mode:

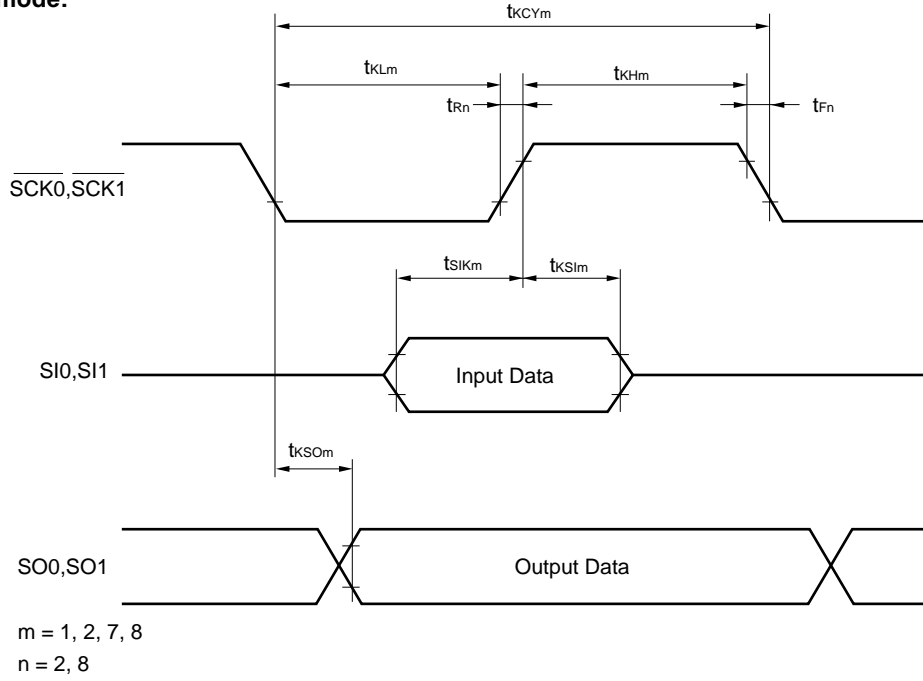

SBI mode (Bus release signal transfer):

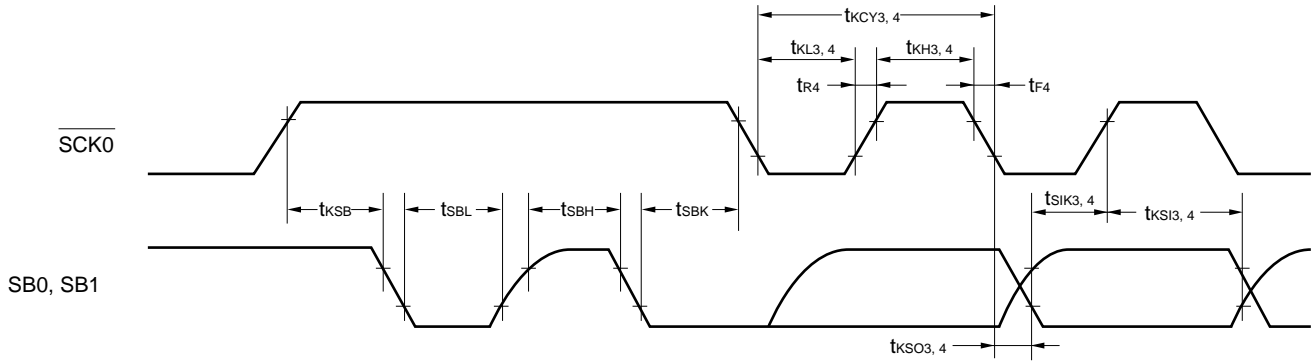

SBI Mode (command signal transfer):

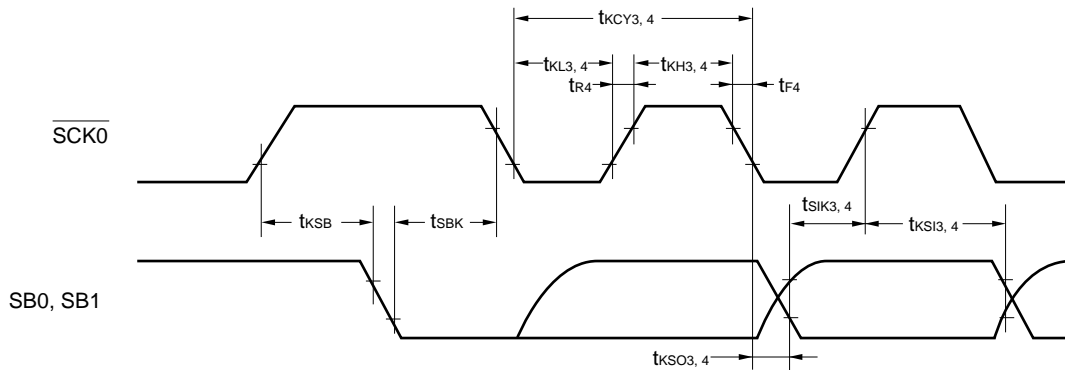

2-wire serial I/O mode:

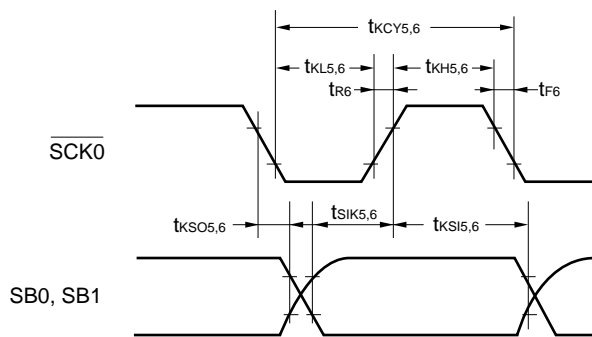

3-wire serial I/O mode with automatic transmit/receive function:

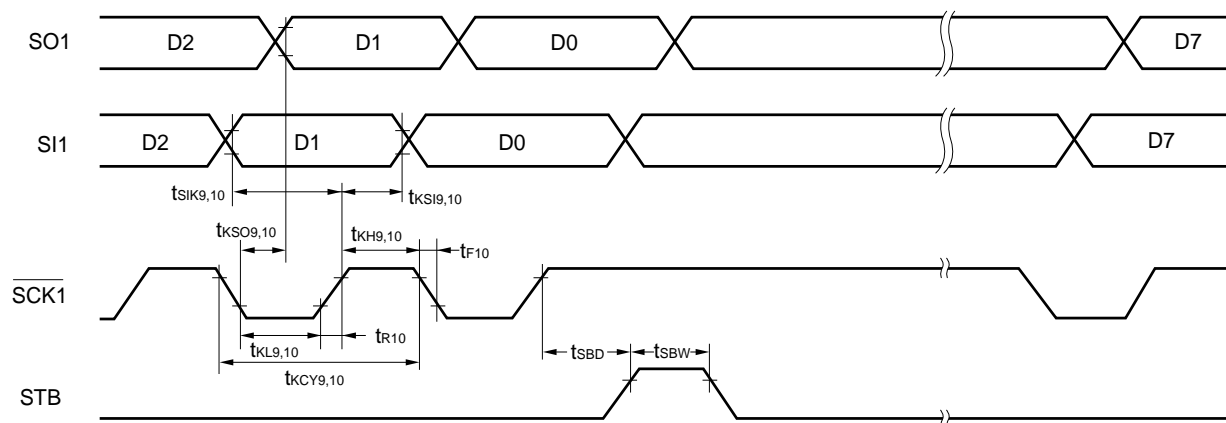

3-wire serial I/O mode with automatic transmit/receive function (busy processing):

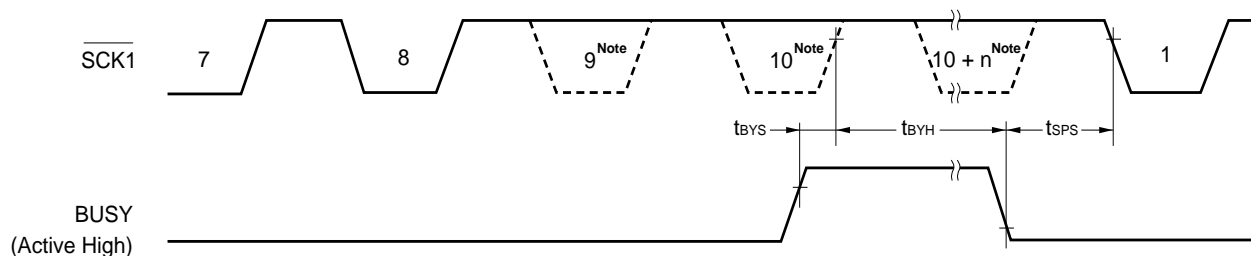

Note The signal is not actually driven low here; it is shown as such to indicate the timing.

A/D converter characteristics ($T_A = -40$ to $+85$ °C, $AV_{DD} = V_{DD} = 1.8$ to 5.5 V, $AV_{SS} = V_{SS} = 0$ V)

Parameter	Symbol	Test Conditions	MIN.	TYP.	MAX.	Unit
Resolution			8	8	8	bit
Overall error Note		$2.7\text{ V} \leq AV_{REF} \leq AV_{DD}$			0.6	%
		$1.8\text{ V} \leq AV_{REF} < 2.7\text{ V}$			1.4	%
Conversion time	t_{CONV}	$2.0\text{ V} \leq AV_{DD} \leq 5.5\text{ V}$	19.1		200	μs
		$1.8\text{ V} \leq AV_{DD} < 2.0\text{ V}$	38.2		200	μs
Sampling time	t_{SAMP}		$24/f_x$			μs
Analog input voltage	V_{IAN}		AV_{SS}		AV_{REF}	V
Reference voltage	AV_{REF}		1.8		AV_{DD}	V
$AV_{REF}-AV_{SS}$ resistance	RA_{IREF}		4	14		kΩ

Note Overall error excluding quantization error ($\pm 1/2$ LSB). It is indicated as a ratio to the full-scale value.

Data Memory STOP Mode Low Supply Voltage Data Retention Characteristics ($T_A = -40$ to $+85$ °C)

Parameter	Symbol	Test Conditions	MIN.	TYP.	MAX.	Unit
Data retention supply voltage	V_{DDDR}		1.8		5.5	V
Data retention supply current	I_{DDDR}	$V_{DDDR} = 1.8\text{ V}$ Subsystem clock stop and feedback resistor disconnected		0.1	10	μA
Release signal set time	t_{SREL}		0			μs
Oscillation stabilization wait time	t_{WAIT}	Release by \overline{RESET}		$2^{18}/f_x$		ms
		Release by interrupt		Note		ms

Note In combination with bit 0 to bit 2 (OSTS0 to OSTS2) of oscillation stabilization time select register, selection of $2^{13}/f_x$ and $2^{15}/f_x$ to $2^{18}/f_x$ is possible.

Data Retention Timing (STOP Mode Release by \overline{RESET})

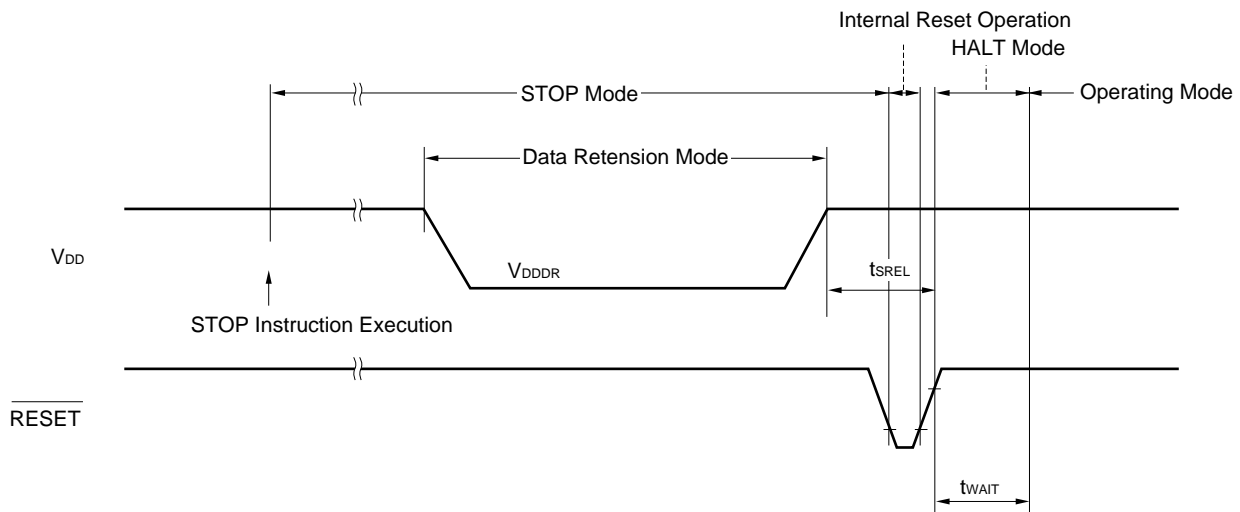

Data Retention Timing (Standby Release Signal : STOP Mode Release by Interrupt Signal)

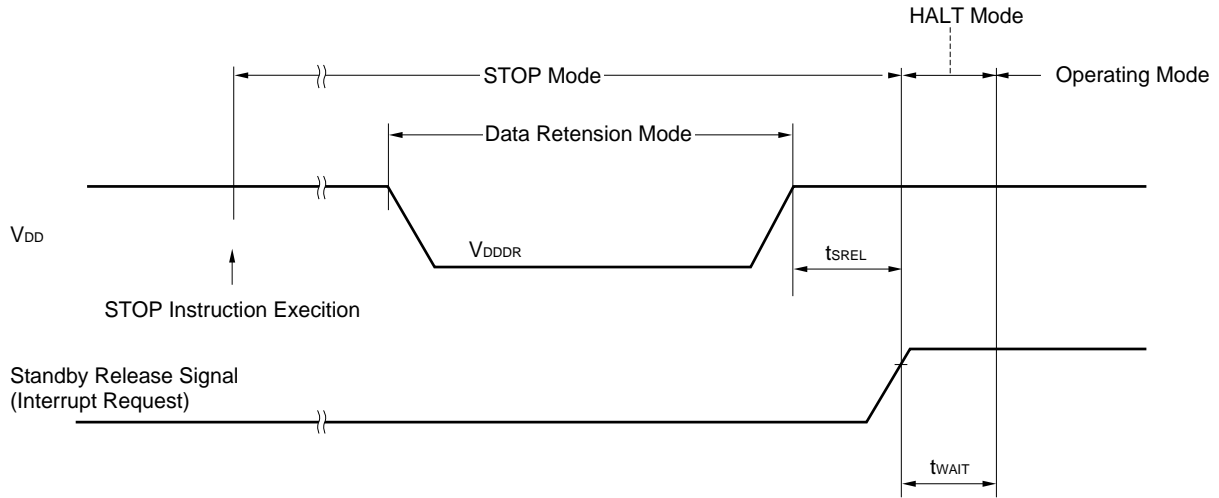

Interrupt Input Timing

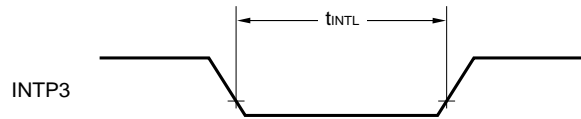
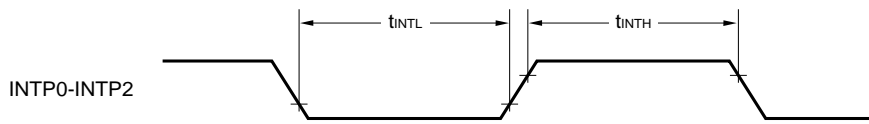

\overline{RESET} Input Timing

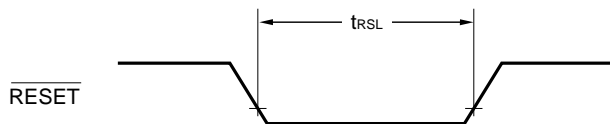

12. PACKAGE DRAWINGS

64 PIN PLASTIC SHRINK DIP (750 mil)

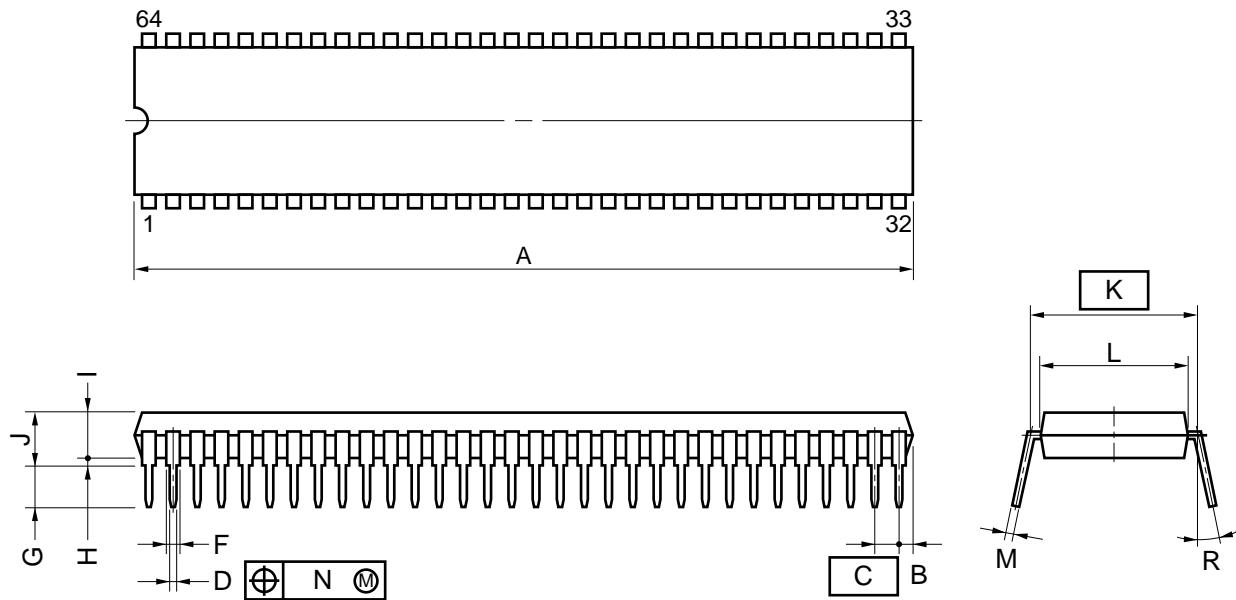

NOTE

- 1) Each lead centerline is located within 0.17 mm (0.007 inch) of its true position (T.P.) at maximum material condition.
- 2) Item "K" to center of leads when formed parallel.

ITEM	MILLIMETERS	INCHES
A	58.68 MAX.	2.311 MAX.
B	1.78 MAX.	0.070 MAX.
C	1.778 (T.P.)	0.070 (T.P.)
D	0.50±0.10	0.020 ^{+0.004} _{-0.005}
F	0.9 MIN.	0.035 MIN.
G	3.2±0.3	0.126±0.012
H	0.51 MIN.	0.020 MIN.
I	4.31 MAX.	0.170 MAX.
J	5.08 MAX.	0.200 MAX.
K	19.05 (T.P.)	0.750 (T.P.)
L	17.0	0.669
M	0.25 ^{+0.10} _{-0.05}	0.010 ^{+0.004} _{-0.003}
N	0.17	0.007
R	0-15°	0-15°

P64C-70-750A,C-1

Remark Dimensions and materials of ES products are the same as those of mass-production products.

64 PIN PLASTIC QFP (□14)

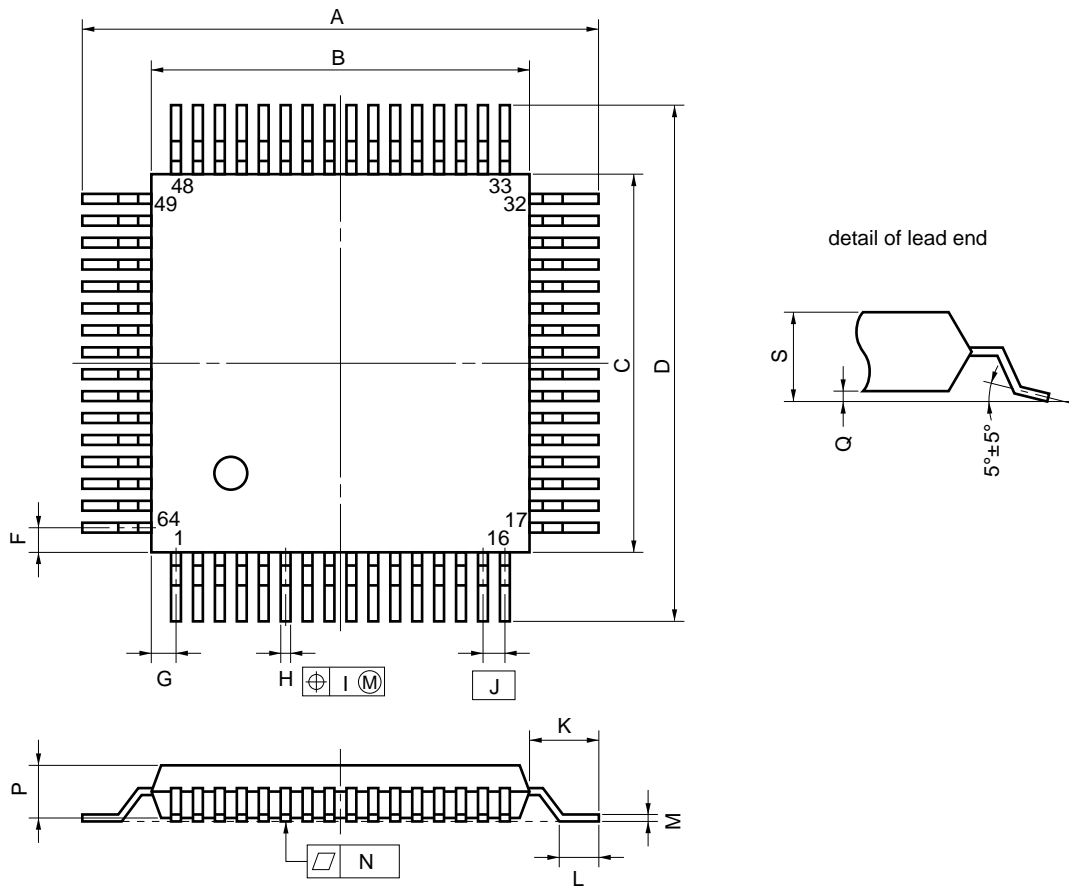

NOTE
 Each lead centerline is located within 0.15 mm (0.006 inch) of its true position (T.P.) at maximum material condition.

P64GC-80-AB8-2

ITEM	MILLIMETERS	INCHES
A	17.6±0.4	0.693±0.016
B	14.0±0.2	0.551 ^{+0.009} _{-0.008}
C	14.0±0.2	0.551 ^{+0.009} _{-0.008}
D	17.6±0.4	0.693±0.016
F	1.0	0.039
G	1.0	0.039
H	0.35±0.10	0.014 ^{+0.004} _{-0.005}
I	0.15	0.006
J	0.8 (T.P.)	0.031 (T.P.)
K	1.8±0.2	0.071±0.008
L	0.8±0.2	0.031 ^{+0.009} _{-0.008}
M	0.15 ^{+0.10} _{-0.05}	0.006 ^{+0.004} _{-0.003}
N	0.10	0.004
P	2.55	0.100
Q	0.1±0.1	0.004±0.004
S	2.85 MAX.	0.112 MAX.

Remark Dimensions and materials of ES products are the same as those of mass-production products.

13. RECOMMENDED SOLDERING CONDITIONS

These products should be soldered and mounted under the conditions recommended in the table below.

For detail of recommended soldering conditions, refer to the information document **Semiconductor Device Mounting Technology Manual (C10535E)**.

For soldering methods and conditions other than those recommended below, contact our salespersonnel.

Table 13-1. Surface Mounting Type Soldering Conditions

μPD78011HGC(A)-xxx-AB8 : 64-Pin Plastic QFP (14 × 14 mm)

μPD78012HGC(A)-xxx-AB8 : 64-Pin Plastic QFP (14 × 14 mm)

μPD78013HGC(A)-xxx-AB8 : 64-Pin Plastic QFP (14 × 14 mm)

μPD78014HGC(A)-xxx-AB8 : 64-Pin Plastic QFP (14 × 14 mm)

Soldering Method	Soldering Conditions	Recommended Condition Symbol
Infrared reflow	Package peak temperature: 235 °C, Duration: 30 sec. max. (at 210 °C or above), Number of times: Thrice max.	IR35-00-3
VPS	Package peak temperature: 215 °C, Duration: 40 sec. max. (at 200 °C or above), Number of times: Thrice max.	VP15-00-3
Wave soldering	Solder bath temperature: 260 °C max. Duration: 10 sec. max. Number of times: Once Preliminary heat temperature: 120 °C max. (Package surface temperature)	WS60-00-1
Partial heating	Pin temperature: 300 °C max., Duration: 3 sec. max. (per device side)	—

Caution Use more than one soldering method should be avoided (except in the case of partial heating).

Table 13-2. Insertion Type Soldering Conditions

μPD78011HCW(A)-xxx : 64-Pin Plastic Shrink DIP (750 mil)

μPD78012HCW(A)-xxx : 64-Pin Plastic Shrink DIP (750 mil)

μPD78013HCW(A)-xxx : 64-Pin Plastic Shrink DIP (750 mil)

μPD78014HCW(A)-xxx : 64-Pin Plastic Shrink DIP (750 mil)

Soldering Method	Soldering Conditions
Wave soldering (pin only)	Solder bath temperature: 260°C max., Duration: 10 sec. max.
Partial heating	Pin temperature: 300°C max., Duration: 3 sec. max. (per pin)

Caution Wave soldering is only for the lead part in order that jet solder can not contact with the chip directly.

APPENDIX A. DEVELOPMENT TOOLS

The following development tools are available for the development of systems using the μ PD78014H subseries.

Language processor software

RA78K/0 Notes 1, 2, 3, 4	Assembler package common to 78K/0 series
CC78K0 Notes 1, 2, 3, 4	C compiler package common to 78K/0 series
DF78014 Notes 1, 2, 3, 4, 6	Device file common to μ PD78014 subseries
CC78K0-L Notes 1, 2, 3, 4	C compiler library source file common to 78K/0 series

Debugging tools

IE-78000-R	In-circuit emulator common to 78K/0 series
IE-78000R-A	In-circuit emulator common to 78K/0 series (for integrated debugger)
IE-78000-R-BK	Break board common to 78K/0 series
IE-78014-R-EM-A	Emulation board common to μ PD78018F and 78018FY subseries ($V_{DD} = 3.0$ to 6.0 V)
EP-78240CW-R	Emulation probe common to μ PD78244 subseries
EV-9200GC-64	Socket mounted on printed wiring board of target system created for 64-pin plastic QFP (GC-AB8 type)
SM78K0 Notes 5, 6, 7	System emulator common to 78K/0 series
ID78K0 Notes 4, 5, 6, 7	Integrated debugger common to 78K/0 series
SD78K/0 Notes 1, 2	Screen debugger for IE-78000-R
DF78014 Notes 1, 2, 3, 4, 5, 6, 7	Device file common to μ PD78014 subseries

Real-Time OS

RX78K/0 Notes 1, 2	Real-time OS for 78K/0 series
MX78K0 Notes 1, 2	OS for 78K/0 series

Fuzzy Inference Development Support System

FE9000 Note 1 /FE9200 Note 6	Fuzzy knowledge data creation tool
FT9080 Note 1 /FT9085 Note 2	Translator
FI78K0 Notes 1, 2	Fuzzy inference module
FD78K0 Notes 1, 2	Fuzzy inference debugger

Notes 1. PC-9800 series (MS-DOS™) based

2. IBM PC/AT™ and compatible machine (PC DOS™/IBM DOS™/MS-DOS) based
3. HP9000 series 300™ (HP-UX™) based
4. HP9000 series 700™ (HP-UX) based, SPARCstation™ (SunOS™) based, EWS-4800 series (EWS-UX/V) based
5. PC-9800 series (MS-DOS + Windows™) based
6. IBM PC/AT and compatible machine (PC DOS/IBM DOS/MS-DOS + Windows) based
7. NEWS™ (NEWS-OS™) based

Remarks 1. For development tools manufactured by a third party, refer to the **78K/0 Series Selection Guide (U11126E)**.

2. RA78K/0, CC78K/0, SM78K0, ID78K0, SD78K/0, and RX78K/0 are used in combination with DF78014.

APPENDIX B. RELATED DOCUMENTS

Device Related Documents

Document Name	Document No.	
	Japanese	English
μPD78014H Subseries User's Manual	Planned to publish	Planned to publish
μPD78011H(A), 78012H(A), 78013H(A), 78014H(A) Data Sheet	U12174J	This document
78K/0 Series User's Manual - Instruction	IEU-849	IEU-1372
78K/0 Series Instruction List	U10903J	—
78K/0 Series Instruction Set	U10904J	—
μPD78014H Subseries Special Function Register List	Planned to publish	—

Development Tools Documents (User's Manual)

Document Name		Document No.	
		Japanese	English
RA78K Series Assembler Package	Operation	EEU-809	EEU-1399
	Language	EEU-815	EEU-1404
RA78K Series Structured Assembler Preprocessor		EEU-817	EEU-1402
RA78K0 Assembler Package	Operation	U11802J	U11802E
	Assembly Language	U11801J	U11081E
	Structural Assembly Language	U11789J	U11789E
CC78K Series C Compiler	Operation	EEU-656	EEU-1280
	Language	EEU-655	EEU-1284
CC78K/0 C Compiler	Operation	11517J	—
	Language	11518J	—
CC78K/0 C Compiler Application Note	Programming Know-how	EEA-618	EEA-1208
CC78K Series Library Source File		EEU-777	—
IE-78000-R		EEU-810	U11376E
IE-78000-R-A		U10057J	U10057E
IE-78000-R-BK		EEU-867	EEU-1427
IE-78014-R-EM-A		EEU-962	U10418E
EP-78240		EEU-986	U10332E
SM78K0 System Simulator Windows Based	Reference	U10181J	U10181E
SM78K Series System Simulator	External Components User Open Interface	U10092J	U10092E
ID78K0 Integrated Debugger EWS Based	Reference	U11151J	—
ID78K0 Integrated Debugger PC Based	Reference	U11539J	U11539E
ID78K0 Integrated Debugger Windows Based	Guide	U11649J	U11649E
SD78K/0 Screen Debugger	Introduction	EEU-852	—
PC-9800 Series (MS-DOS) Based	Reference	U10952J	—
SD78K/0 Screen Deb	Introduction	EEU-5024	EEU-1414
IBM PC/AT (PC DOS) Based	Reference	U11279J	U11279E

Caution The contents of the above related documents are subject to change without notice. The latest documents should be used for design, etc.

Embedded Software Documents (User's Manual)

Document Name		Document No.	
		Japanese	English
78K/0 Series Real-Time OS	Fundamental	U11537J	—
	Installation	U11536J	—
	Technical	U11538J	—
78K/0 Series OS MX78K0	Fundamental	EEU-5010	—
Fuzzy Knowledge Data Creation Tool		EEU-829	EEU-1438
78K/0, 78K/II, 87AD Series Fuzzy Inference Development Support System - Translator		EEU-862	EEU-1444
78K/0 Series Fuzzy Inference Development Support System - Fuzzy Inference Module		EEU-858	EEU-1441
78K/0 Series Fuzzy Inference Development Support System - Fuzzy Inference Debugger		EEU-921	EEU-1458

Other Documents

Document Name		Document No.	
		Japanese	English
IC Package Manual		C10943X	
Semiconductor Device Mounting Technology Manual		C10535J	C10535E
Quality Grades on NEC Semiconductor Device		C11531J	C11531E
NEC Semiconductor Device Reliability/Quality Control System		C10983J	C10983E
Electrostatic Discharge (ESD) Test		MEM-539	—
Guide to Quality Assurance for Semiconductor Device		C11893J	MEI-1202
Guide for Products Related to Micro-Computer: Other Companies		U11416J	—

Caution The contents of the above related documents are subject to change without notice. The latest documents should be used for design, etc.

NOTES FOR CMOS DEVICES

① PRECAUTION AGAINST ESD FOR SEMICONDUCTORS

Note: Strong electric field, when exposed to a MOS device, can cause destruction of the gate oxide and ultimately degrade the device operation. Steps must be taken to stop generation of static electricity as much as possible, and quickly dissipate it once, when it has occurred. Environmental control must be adequate. When it is dry, humidifier should be used. It is recommended to avoid using insulators that easily build static electricity. Semiconductor devices must be stored and transported in an anti-static container, static shielding bag or conductive material. All test and measurement tools including work bench and floor should be grounded. The operator should be grounded using wrist strap. Semiconductor devices must not be touched with bare hands. Similar precautions need to be taken for PW boards with semiconductor devices on it.

② HANDLING OF UNUSED INPUT PINS FOR CMOS

Note: No connection for CMOS device inputs can be cause of malfunction. If no connection is provided to the input pins, it is possible that an internal input level may be generated due to noise, etc., hence causing malfunction. CMOS device behave differently than Bipolar or NMOS devices. Input levels of CMOS devices must be fixed high or low by using a pull-up or pull-down circuitry. Each unused pin should be connected to V_{DD} or GND with a resistor, if it is considered to have a possibility of being an output pin. All handling related to the unused pins must be judged device by device and related specifications governing the devices.

③ STATUS BEFORE INITIALIZATION OF MOS DEVICES

Note: Power-on does not necessarily define initial status of MOS device. Production process of MOS does not define the initial operation status of the device. Immediately after the power source is turned ON, the devices with reset function have not yet been initialized. Hence, power-on does not guarantee out-pin levels, I/O settings or contents of registers. Device is not initialized until the reset signal is received. Reset operation must be executed immediately after power-on for devices having reset function.

Regional Information

Some information contained in this document may vary from country to country. Before using any NEC product in your application, please contact the NEC office in your country to obtain a list of authorized representatives and distributors. They will verify:

- Device availability
- Ordering information
- Product release schedule
- Availability of related technical literature
- Development environment specifications (for example, specifications for third-party tools and components, host computers, power plugs, AC supply voltages, and so forth)
- Network requirements

In addition, trademarks, registered trademarks, export restrictions, and other legal issues may also vary from country to country.

NEC Electronics Inc. (U.S.)

Santa Clara, California
Tel: 800-366-9782
Fax: 800-729-9288

NEC Electronics (Germany) GmbH

Duesseldorf, Germany
Tel: 0211-65 03 02
Fax: 0211-65 03 490

NEC Electronics (UK) Ltd.

Milton Keynes, UK
Tel: 01908-691-133
Fax: 01908-670-290

NEC Electronics Italiana s.r.l.

Milano, Italy
Tel: 02-66 75 41
Fax: 02-66 75 42 99

NEC Electronics (Germany) GmbH

Benelux Office
Eindhoven, The Netherlands
Tel: 040-2445845
Fax: 040-2444580

NEC Electronics (France) S.A.

Velizy-Villacoublay, France
Tel: 01-30-67 58 00
Fax: 01-30-67 58 99

NEC Electronics (France) S.A.

Spain Office
Madrid, Spain
Tel: 01-504-2787
Fax: 01-504-2860

NEC Electronics (Germany) GmbH

Scandinavia Office
Taebly, Sweden
Tel: 08-63 80 820
Fax: 08-63 80 388

NEC Electronics Hong Kong Ltd.

Hong Kong
Tel: 2886-9318
Fax: 2886-9022/9044

NEC Electronics Hong Kong Ltd.

Seoul Branch
Seoul, Korea
Tel: 02-528-0303
Fax: 02-528-4411

NEC Electronics Singapore Pte. Ltd.

United Square, Singapore 1130
Tel: 253-8311
Fax: 250-3583

NEC Electronics Taiwan Ltd.

Taipei, Taiwan
Tel: 02-719-2377
Fax: 02-719-5951

NEC do Brasil S.A.

Sao Paulo-SP, Brasil
Tel: 011-889-1680
Fax: 011-889-1689

FIP and IEBus are trademarks of NEC Corporation.

MS-DOS and Windows are trademarks of Microsoft Corporation.

IBM-DOS, PC/AT, and PC DOS are trademarks of IBM Corporation.

HP9000 Series 300, HP9000 series 700, and HP-UX are trademarks of Hewlett-Packard Company.

SPARCstation is a trademark of SPARC International, Inc.

SunOS is a trademark of Sun Microsystems, Inc.

NEWS and NEWS-OS are trademarks of Sony Corporation.

Some related documents are preliminary versions. This document, however, is not indicated as preliminary.

The export of this product from Japan is regulated by the Japanese government. To export this product may be prohibited without governmental license, the need for which must be judged by the customer. The export or re-export of this product from a country other than Japan may also be prohibited without a license from that country. Please call an NEC sales representative.

No part of this document may be copied or reproduced in any form or by any means without the prior written consent of NEC Corporation. NEC Corporation assumes no responsibility for any errors which may appear in this document.

NEC Corporation does not assume any liability for infringement of patents, copyrights or other intellectual property rights of third parties by or arising from use of a device described herein or any other liability arising from use of such device. No license, either express, implied or otherwise, is granted under any patents, copyrights or other intellectual property rights of NEC Corporation or others.

While NEC Corporation has been making continuous effort to enhance the reliability of its semiconductor devices, the possibility of defects cannot be eliminated entirely. To minimize risks of damage or injury to persons or property arising from a defect in an NEC semiconductor device, customers must incorporate sufficient safety measures in its design, such as redundancy, fire-containment, and anti-failure features.

NEC devices are classified into the following three quality grades:

"Standard", "Special", and "Specific". The Specific quality grade applies only to devices developed based on a customer designated "quality assurance program" for a specific application. The recommended applications of a device depend on its quality grade, as indicated below. Customers must check the quality grade of each device before using it in a particular application.

Standard: Computers, office equipment, communications equipment, test and measurement equipment, audio and visual equipment, home electronic appliances, machine tools, personal electronic equipment and industrial robots

Special: Transportation equipment (automobiles, trains, ships, etc.), traffic control systems, anti-disaster systems, anti-crime systems, safety equipment and medical equipment (not specifically designed for life support)

Specific: Aircrafts, aerospace equipment, submersible repeaters, nuclear reactor control systems, life support systems or medical equipment for life support, etc.

The quality grade of NEC devices is "Standard" unless otherwise specified in NEC's Data Sheets or Data Books. If customers intend to use NEC devices for applications other than those specified for Standard quality grade, they should contact an NEC sales representative in advance.

Anti-radioactive design is not implemented in this product.