



HYB25D256400/800T/AT 256-MBit Double Data Rate SDRAM

Features

CAS Latency and Frequency

CAS Latency	Maximum Operating Frequency (MHz)		
	DDR266A -7	DDR266B -7.5	DDR200 -8
2	133	125	100
2.5	143	133	125

- Double data rate architecture: two data transfers per clock cycle
- Bidirectional data strobe (DQS) is transmitted and received with data, to be used in capturing data at the receiver
- DQS is edge-aligned with data for reads and is center-aligned with data for writes
- Differential clock inputs (CK and $\overline{\text{CK}}$)
- Four internal banks for concurrent operation

- Data mask (DM) for write data
- DLL aligns DQ and DQS transitions with CK transitions.
- Commands entered on each positive CK edge; data and data mask referenced to both edges of DQS
- Burst lengths: 2, 4, or 8
- CAS Latency: 2, 2.5
- Auto Precharge option for each burst access
- Auto Refresh and Self Refresh Modes
- 7.8 μs Maximum Average Periodic Refresh Interval
- 2.5V (SSTL_2 compatible) I/O
- $V_{\text{DDQ}} = 2.5\text{V} \pm 0.2\text{V} / V_{\text{DD}} = 2.5\text{V} \pm 0.2\text{V}$
- TSOP66 package

Description

The 256Mb DDR SDRAM is a high-speed CMOS, dynamic random-access memory containing 268,435,456 bits. It is internally configured as a quad-bank DRAM.

The 256Mb DDR SDRAM uses a double-data-rate architecture to achieve high-speed operation. The double data rate architecture is essentially a $2n$ prefetch architecture with an interface designed to transfer two data words per clock cycle at the I/O pins. A single read or write access for the 256Mb DDR SDRAM effectively consists of a single $2n$ -bit wide, one clock cycle data transfer at the internal DRAM core and two corresponding n -bit wide, one-half-clock-cycle data transfers at the I/O pins.

A bidirectional data strobe (DQS) is transmitted externally, along with data, for use in data capture at the receiver. DQS is a strobe transmitted by the DDR SDRAM during Reads and by the memory controller during Writes. DQS is edge-aligned with data for Reads and center-aligned with data for Writes.

The 256Mb DDR SDRAM operates from a differential clock (CK and $\overline{\text{CK}}$; the crossing of CK going HIGH and $\overline{\text{CK}}$ going LOW is referred to as the positive edge of CK). Commands (address and control signals) are registered at every positive edge of CK. Input data is registered on both edges of DQS, and output data is referenced to both edges of DQS, as well as to both edges of CK.

Read and write accesses to the DDR SDRAM are burst oriented; accesses start at a selected location and continue for a programmed number of locations in a programmed sequence. Accesses begin with the registration of an Active command, which is then followed by a Read or Write command. The address bits registered coincident with the Active command are used to select the bank and row to be accessed. The address bits registered coincident with the Read or Write command are used to select the bank and the starting column location for the burst access.

The DDR SDRAM provides for programmable Read or Write burst lengths of 2, 4 or 8 locations. An Auto Precharge function may be enabled to provide a self-timed row precharge that is initiated at the end of the burst access.

As with standard SDRAMs, the pipelined, multibank architecture of DDR SDRAMs allows for concurrent operation, thereby providing high effective bandwidth by hiding row precharge and activation time.

An auto refresh mode is provided along with a power-saving power-down mode. All inputs are compatible with the JEDEC Standard for SSTL_2. All outputs are SSTL_2, Class II compatible.

Note: The functionality described and the timing specifications included in this data sheet are for the DLL Enabled mode of operation.

Pin Configuration

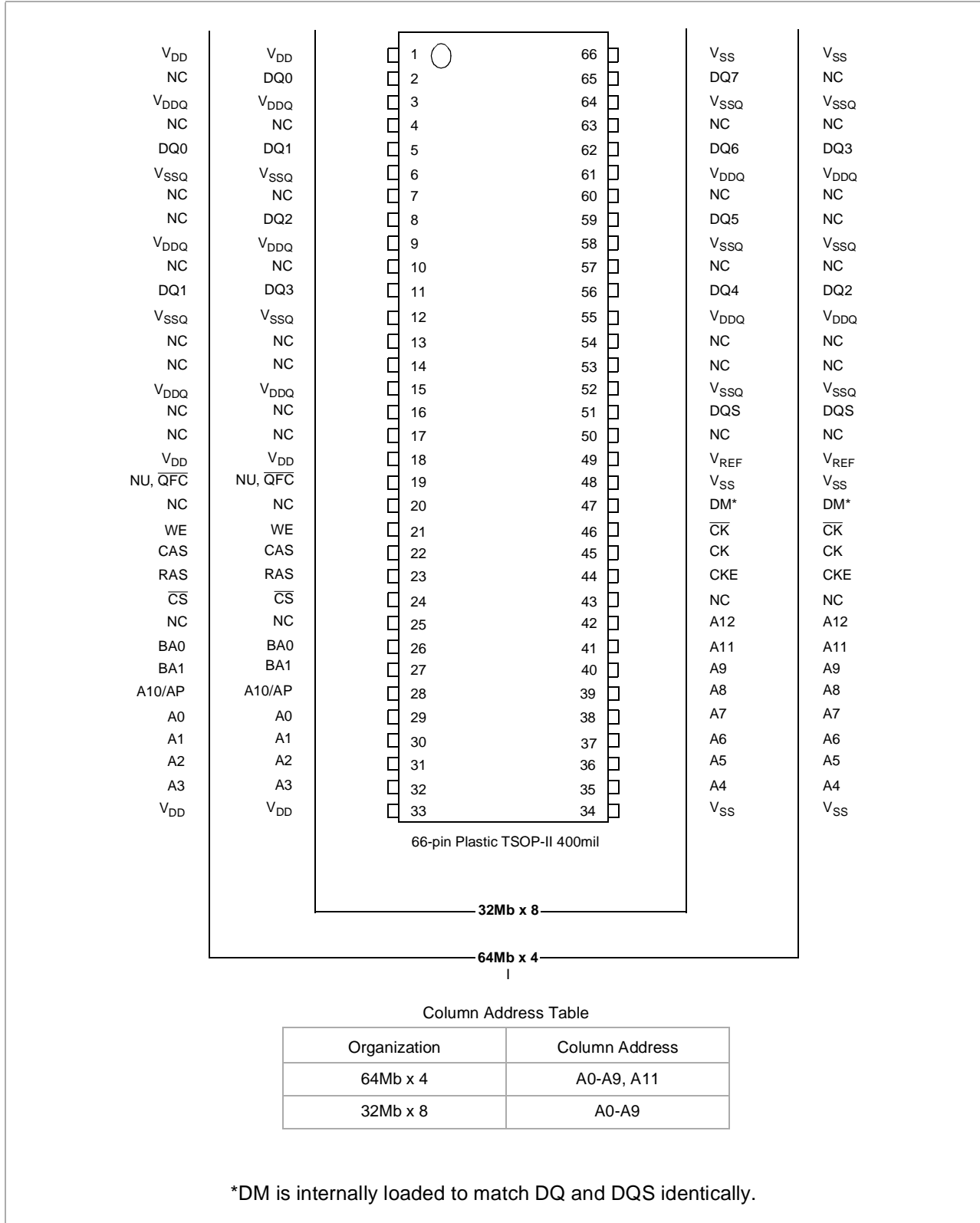

Input/Output Functional Description

Symbol	Type	Function
CK, \overline{CK}	Input	Clock: CK and \overline{CK} are differential clock inputs. All address and control input signals are sampled on the crossing of the positive edge of CK and negative edge of \overline{CK} . Output (read) data is referenced to the crossings of CK and \overline{CK} (both directions of crossing).
CKE	Input	Clock Enable: CKE HIGH activates, and CKE Low deactivates, internal clock signals and device input buffers and output drivers. Taking CKE Low provides Precharge Power-Down and Self Refresh operation (all banks idle), or Active Power-Down (row Active in any bank). CKE is synchronous for power down entry and exit, and for self refresh entry. CKE is asynchronous for self refresh exit. CKE must be maintained high throughout read and write accesses. Input buffers, excluding CK, \overline{CK} and CKE are disabled during power-down. Input buffers, excluding CKE, are disabled during self refresh.
\overline{CS}	Input	Chip Select: All commands are masked when \overline{CS} is registered HIGH. \overline{CS} provides for external bank selection on systems with multiple banks. \overline{CS} is considered part of the command code. The standard pinout includes one \overline{CS} pin.
\overline{RAS} , \overline{CAS} , \overline{WE}	Input	Command Inputs: RAS, CAS and WE (along with \overline{CS}) define the command being entered.
DM	Input	Input Data Mask: DM is an input mask signal for write data. Input data is masked when DM is sampled HIGH coincident with that input data during a Write access. DM is sampled on both edges of DQS. Although DM pins are input only, the DM loading matches the DQ and DQS loading.
BA0, BA1	Input	Bank Address Inputs: BA0 and BA1 define to which bank an Active, Read, Write or Precharge command is being applied. BA0 and BA1 also determines if the mode register or extended mode register is to be accessed during a MRS or EMRS cycle.
A0 - A12	Input	Address Inputs: Provide the row address for Active commands, and the column address and Auto Precharge bit for Read/Write commands, to select one location out of the memory array in the respective bank. A10 is sampled during a Precharge command to determine whether the Precharge applies to one bank (A10 LOW) or all banks (A10 HIGH). If only one bank is to be precharged, the bank is selected by BA0, BA1. The address inputs also provide the op-code during a Mode Register Set command.
DQ	Input/Output	Data Input/Output: Data bus.
DQS	Input/Output	Data Strobe: Output with read data, input with write data. Edge-aligned with read data, centered in write data. Used to capture write data.
\overline{QFC}	Output	FET control: Optional. Output during every Read and Write access. Is provided to control isolation switches on modules. Open drain output. Pullup resistor must be tied to V_{DDQ} at second level of assembly. The \overline{QFC} pin is present on this product version, but all timings parameters related to this pin are not tested on the final product and are only guaranteed by design.
NC		No Connect: No internal electrical connection is present.
V_{DDQ}	Supply	DQ Power Supply: 2.5V \pm 0.2V.
V_{SSQ}	Supply	DQ Ground
V_{DD}	Supply	Power Supply: 2.5V \pm 0.2V.
V_{SS}	Supply	Ground
V_{REF}	Supply	SSTL_2 reference voltage: ($V_{DDQ} / 2$)

Ordering Information

Part Number (ASTC)	CAS Latency	Clock (MHz)	CAS Latency	Clock (MHz)	Speed	Org.	Package
HYB25D256400T-7	2.5	143	2	133	DDR266A	x 4	66 pin TSOP-II
HYB25D256800T-7						x 8	
HYB25D256400T-7.5		133		125	DDR266B	x 4	
HYB25D256800T-7.5						x 8	
HYB25D256400T-8		125		100	DDR200	x 4	
HYB25D256800T-8						x 8	

Part Number (WOS)	CAS Latency	Clock (MHz)	CAS Latency	Clock (MHz)	Speed	Org.	Package
HYB25D256400AT-7	2.5	143	2	133	DDR266A	x 4	66 pin TSOP-II
HYB25D256800AT-7						x 8	
HYB25D256400AT-7.5		133		125	DDR266B	x 4	
HYB25D256800AT-7.5						x 8	
HYB25D256400AT-8		125		100	DDR200	x 4	
HYB25D256800AT-8						x 8	

Block Diagram (64Mb x 4)

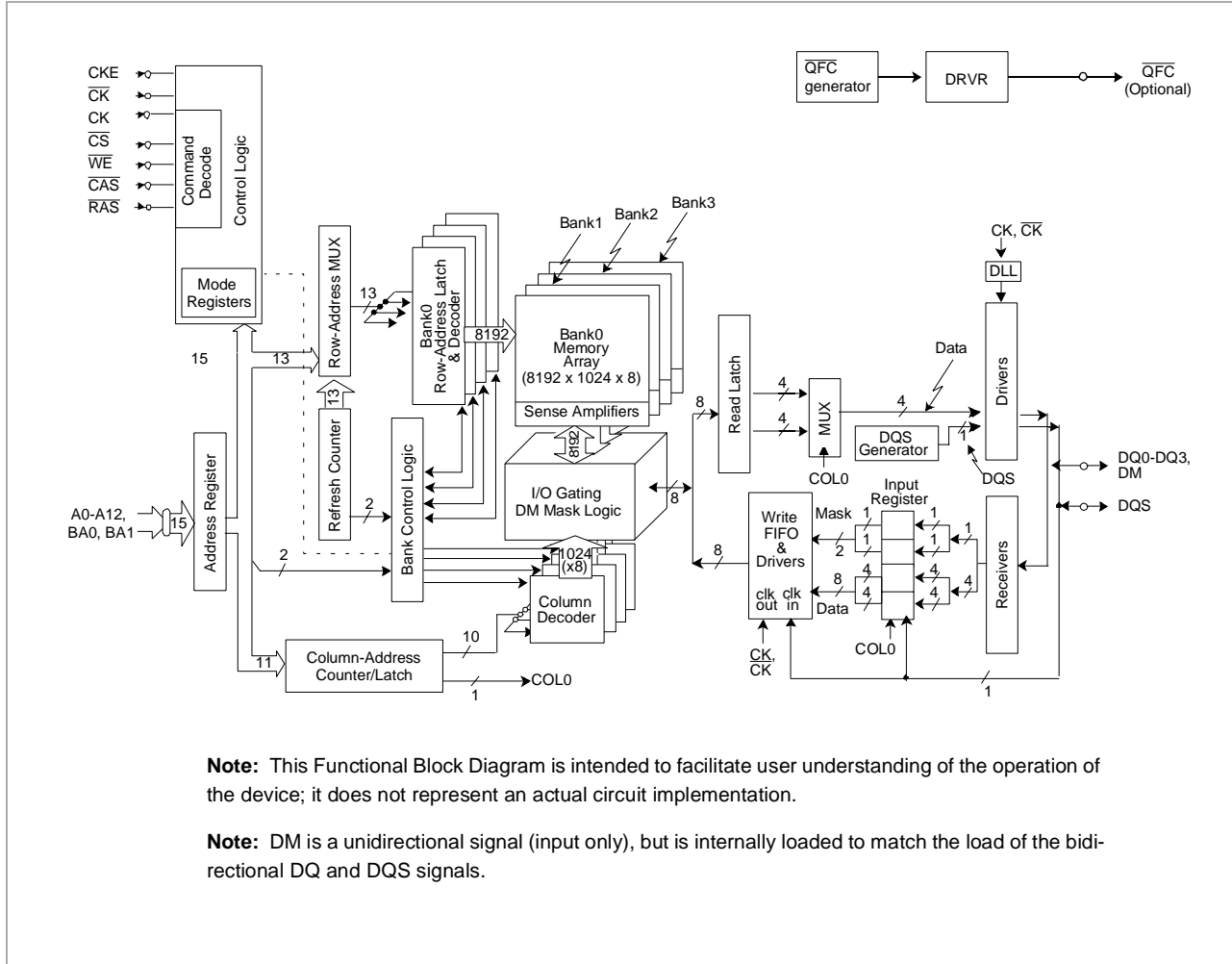

Functional Description

The 256Mb DDR SDRAM is a high-speed CMOS, dynamic random-access memory containing 268, 435, 456 bits. The 256Mb DDR SDRAM is internally configured as a quad-bank DRAM.

The 256Mb DDR SDRAM uses a double-data-rate architecture to achieve high-speed operation. The double-data-rate architecture is essentially a $2n$ prefetch architecture, with an interface designed to transfer two data words per clock cycle at the I/O pins. A single read or write access for the 256Mb DDR SDRAM consists of a single $2n$ -bit wide, one clock cycle data transfer at the internal DRAM core and two corresponding n -bit wide, one-half clock cycle data transfers at the I/O pins.

Read and write accesses to the DDR SDRAM are burst oriented; accesses start at a selected location and continue for a programmed number of locations in a programmed sequence. Accesses begin with the registration of an Active command, which is then followed by a Read or Write command. The address bits registered coincident with the Active command are used to select the bank and row to be accessed (BA0, BA1 select the bank; A0-A12 select the row). The address bits registered coincident with the Read or Write command are used to select the starting column location for the burst access.

Prior to normal operation, the DDR SDRAM must be initialized. The following sections provide detailed information covering device initialization, register definition, command descriptions and device operation.

Initialization

DDR SDRAMs must be powered up and initialized in a predefined manner. Operational procedures other than those specified may result in undefined operation. The following two conditions must be met:

- No power sequencing is specified during power up or power down given the following criteria
- V_{DD} and V_{DDQ} are driven from a single power converter output
- V_{TT} meets the specification
- A minimum resistance of 42 ohms limits the input current from the V_{TT} supply into any pin and V_{REF} tracks $V_{DDQ}/2$
- or
- The following relationship must be followed
- V_{DDQ} is driven after or with V_{DD} such that $V_{DDQ} < V_{DD} + 0.3 V$
- V_{TT} is driven after or with V_{DDQ} such that $V_{TT} < V_{DDQ} + 0.3V$
- V_{REF} is driven after or with V_{DDQ} such that $V_{REF} < V_{DDQ} + 0.3V$

The DQ and DQS outputs are in the High-Z state, where they remain until driven in normal operation (by a read access). After all power supply and reference voltages are stable, and the clock is stable, the DDR SDRAM requires a 200 μ s delay prior to applying an executable command.

Once the 200 μ s delay has been satisfied, a Deselect or NOP command should be applied, and CKE must be brought HIGH. Following the NOP command, a Precharge ALL command must be applied. Next a Mode Register Set command must be issued for the Extended Mode Register, to enable the DLL, then a Mode Register Set command must be issued for the Mode Register, to reset the DLL, and to program the operating parameters. 200 clock cycles are required between the DLL reset and any read command. A Precharge ALL command should be applied, placing the device in the "all banks idle" state

Once in the idle state, two AUTO REFRESH cycles must be performed. Additionally, a Mode Register Set command for the Mode Register, with the reset DLL bit deactivated (i.e. to program operating parameters without resetting the DLL) must be performed. Following these cycles, the DDR SDRAM is ready for normal operation.

Register Definition

Mode Register

The Mode Register is used to define the specific mode of operation of the DDR SDRAM. This definition includes the selection of a burst length, a burst type, a CAS latency, and an operating mode. The Mode Register is programmed via the Mode Register Set command (with BA0 = 0 and BA1 = 0) and retains the stored information until it is programmed again or the device loses power (except for bit A8, which is self-clearing).

Mode Register bits A0-A2 specify the burst length, A3 specifies the type of burst (sequential or interleaved), A4-A6 specify the CAS latency, and A7-A12 specify the operating mode.

The Mode Register must be loaded when all banks are idle, and the controller must wait the specified time before initiating the subsequent operation. Violating either of these requirements results in unspecified operation.

Burst Length

Read and write accesses to the DDR SDRAM are burst oriented, with the burst length being programmable. The burst length determines the maximum number of column locations that can be accessed for a given Read or Write command. Burst lengths of 2, 4, or 8 locations are available for both the sequential and the interleaved burst types.

Reserved states should not be used, as unknown operation or incompatibility with future versions may result.

When a Read or Write command is issued, a block of columns equal to the burst length is effectively selected. All accesses for that burst take place within this block, meaning that the burst wraps within the block if a boundary is reached. The block is uniquely selected by A1-A_i when the burst length is set to two, by A2-A_i when the burst length is set to four and by A3-A_i when the burst length is set to eight (where A_i is the most significant column address bit for a given configuration). The remaining (least significant) address bit(s) is (are) used to select the starting location within the block. The programmed burst length applies to both Read and Write bursts.

Mode Register Operation

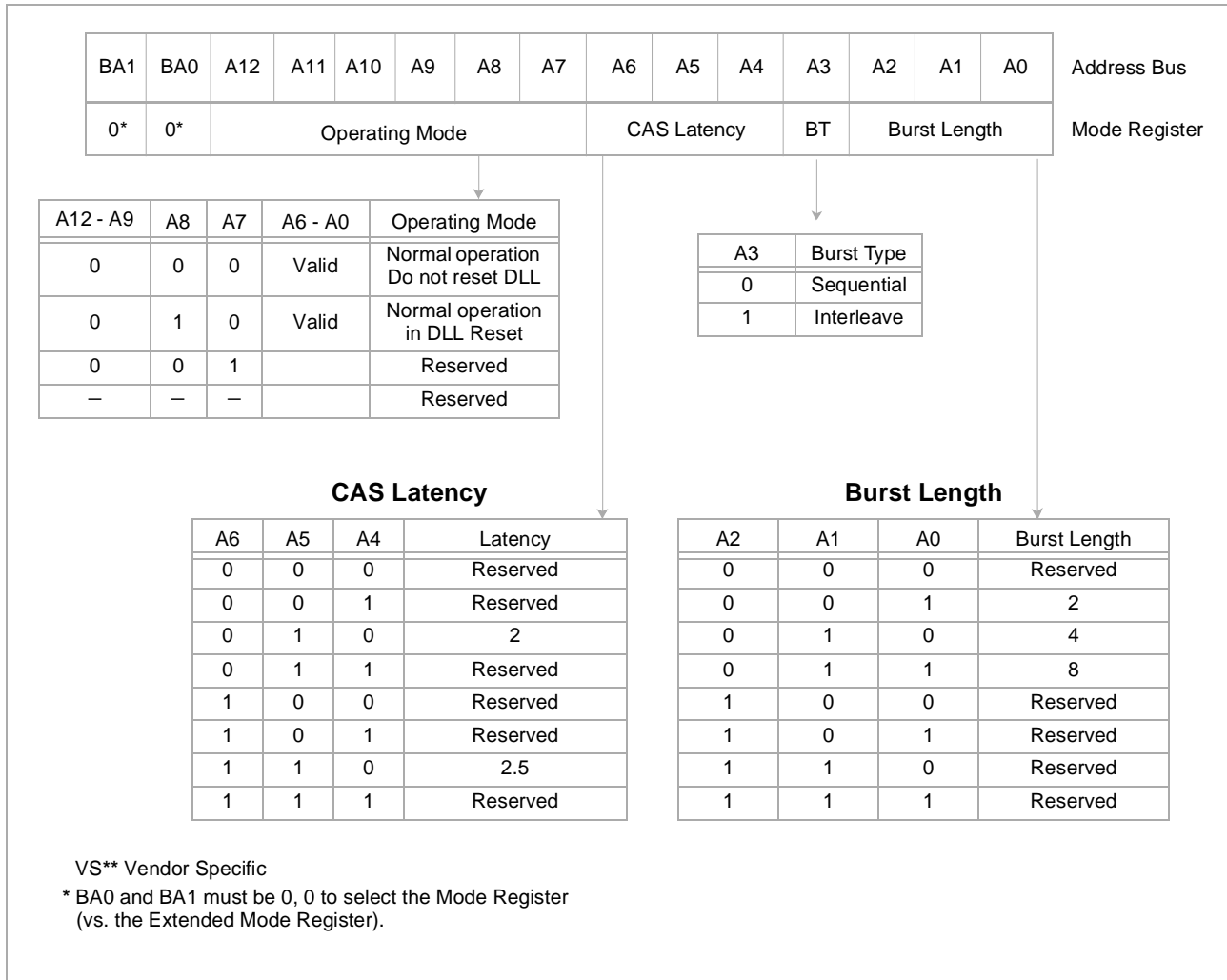

Burst Definition

Burst Length	Starting Column Address			Order of Accesses Within a Burst	
	A2	A1	A0	Type = Sequential	Type = Interleaved
2			0	0-1	0-1
			1	1-0	1-0
4		0	0	0-1-2-3	0-1-2-3
		0	1	1-2-3-0	1-0-3-2
		1	0	2-3-0-1	2-3-0-1
		1	1	3-0-1-2	3-2-1-0
8	0	0	0	0-1-2-3-4-5-6-7	0-1-2-3-4-5-6-7
	0	0	1	1-2-3-4-5-6-7-0	1-0-3-2-5-4-7-6
	0	1	0	2-3-4-5-6-7-0-1	2-3-0-1-6-7-4-5
	0	1	1	3-4-5-6-7-0-1-2	3-2-1-0-7-6-5-4
	1	0	0	4-5-6-7-0-1-2-3	4-5-6-7-0-1-2-3
	1	0	1	5-6-7-0-1-2-3-4	5-4-7-6-1-0-3-2
	1	1	0	6-7-0-1-2-3-4-5	6-7-4-5-2-3-0-1
	1	1	1	7-0-1-2-3-4-5-6	7-6-5-4-3-2-1-0

Notes:

1. For a burst length of two, A1-Ai selects the two-data-element block; A0 selects the first access within the block.
2. For a burst length of four, A2-Ai selects the four-data-element block; A0-A1 selects the first access within the block.
3. For a burst length of eight, A3-Ai selects the eight-data-element block; A0-A2 selects the first access within the block.
4. Whenever a boundary of the block is reached within a given sequence above, the following access wraps within the block.

Burst Type

Accesses within a given burst may be programmed to be either sequential or interleaved; this is referred to as the burst type and is selected via bit A3. The ordering of accesses within a burst is determined by the burst length, the burst type and the starting column address, as shown in *Burst Definition* on page 10.

Read Latency

The Read latency, or CAS latency, is the delay, in clock cycles, between the registration of a Read command and the availability of the first burst of output data. The latency can be programmed 2 or 2.5 clocks.

If a Read command is registered at clock edge n , and the latency is m clocks, the data is available nominally coincident with clock edge $n + m$.

Reserved states should not be used as unknown operation or incompatibility with future versions may result.

Operating Mode

The normal operating mode is selected by issuing a Mode Register Set Command with bits A7-A12 to zero, and bits A0-A6 set to the desired values. A DLL reset is initiated by issuing a Mode Register Set command with bits A7 and A9-A12 each set to zero, bit A8 set to one, and bits A0-A6 set to the desired values. A Mode Register Set command issued to reset the DLL should always be followed by a Mode Register Set command to select normal operating mode.

All other combinations of values for A7-A12 are reserved for future use and/or test modes. Test modes and reserved states should not be used as unknown operation or incompatibility with future versions may result.

Required CAS Latencies

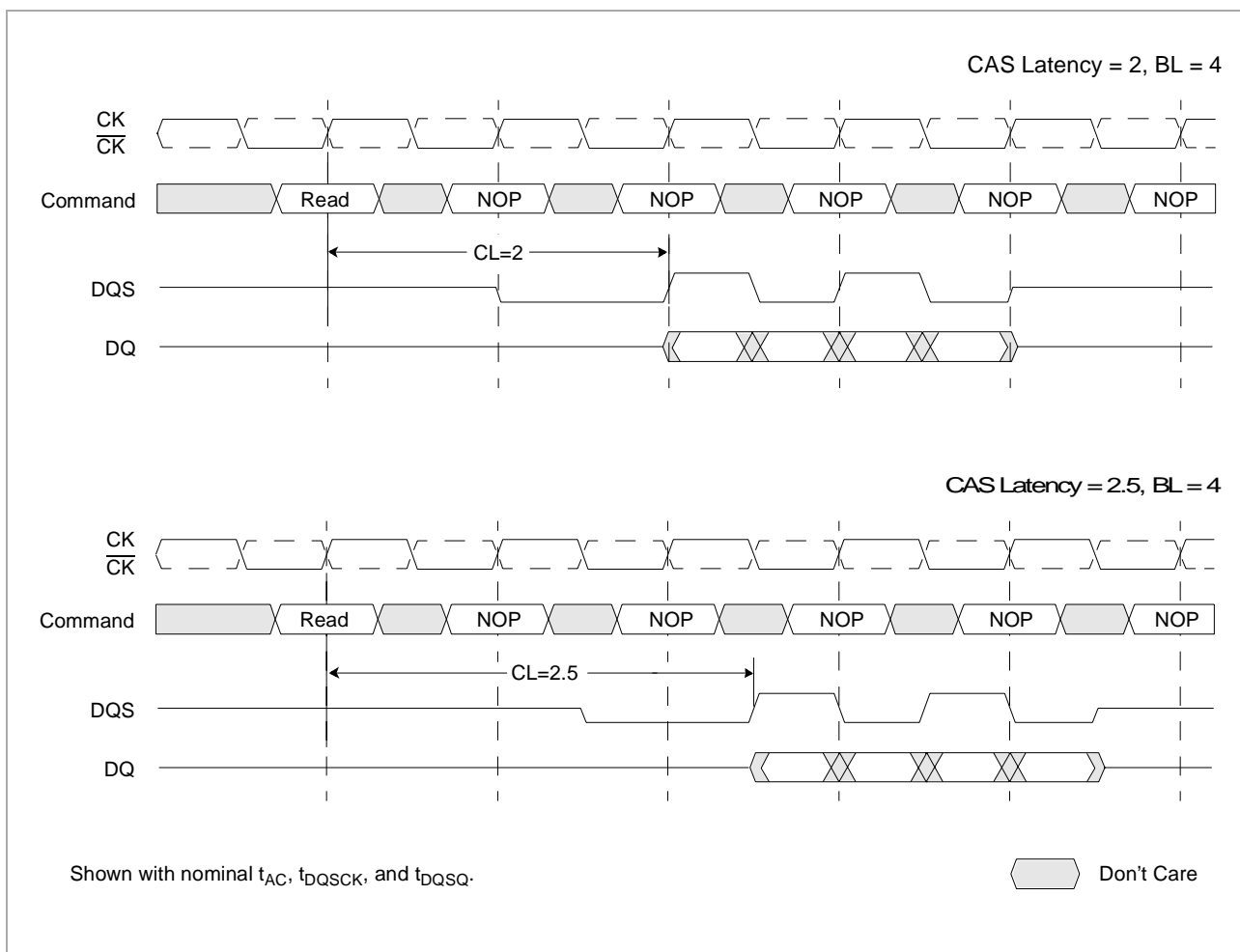

Extended Mode Register

The Extended Mode Register controls functions beyond those controlled by the Mode Register; these additional functions include DLL enable/disable, output drive strength selection (optional), and \overline{QFC} output enable/disable (optional). These functions are controlled via the bits shown in the Extended Mode Register Definition. The Extended Mode Register is programmed via the Mode Register Set command (with BA0 = 1 and BA1 = 0) and retains the stored information until it is programmed again or the device loses power. The Extended Mode Register must be loaded when all banks are idle, and the controller must wait the specified time before initiating any subsequent operation. Violating either of these requirements result in unspecified operation.

DLL Enable/Disable

The DLL must be enabled for normal operation. DLL enable is required during power up initialization, and upon returning to normal operation after having disabled the DLL for the purpose of debug or evaluation. The DLL is automatically disabled when entering self refresh operation and is automatically re-enabled upon exit of self refresh operation. Any time the DLL is enabled, 200 clock cycles must occur before a Read command can be issued. This is the reason 200 clock cycles must occur before issuing a Read or Write command upon exit of self refresh operation.

Output Drive Strength

The normal drive strength for all outputs is specified to be SSTL_2, Class II. I-V curves for the normal drive strength are included in this document.

An option for weak driver support intended for lighter load and/or point-to-point environments is under consideration for future versions of this design. Selection of the weak driver option will reduce the output drive strength by ~ 55% of that of the normal strength.

\overline{QFC} Enable/Disable (optional)

The \overline{QFC} signal is an optional DRAM output control used to isolate module loads (DIMMs) from the system memory bus by means of FET switches when the given module is not being accessed. The \overline{QFC} pin is present on this product version, but all timings parameters related to this pin are not tested on the final product and are only guaranteed by design.

Extended Mode Register Definition

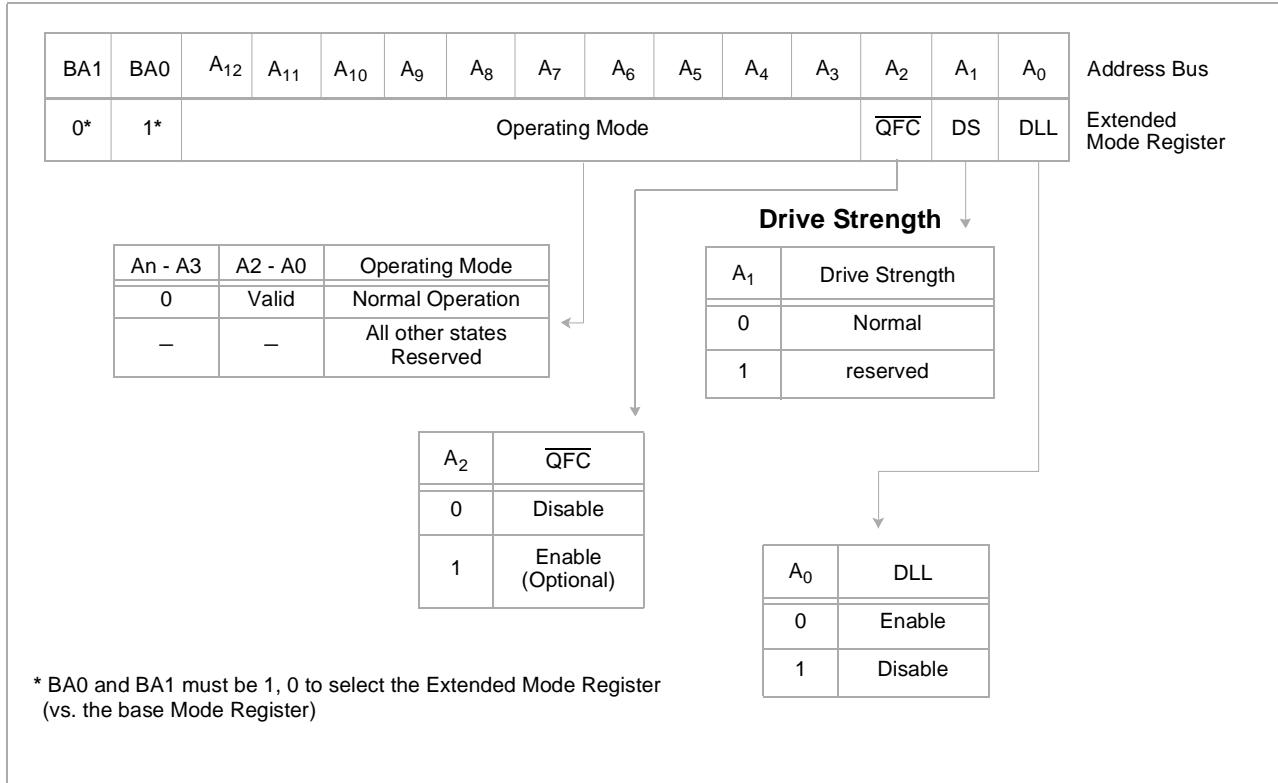

Truth Table 1a: Commands

Name (Function)	\overline{CS}	\overline{RAS}	\overline{CAS}	\overline{WE}	Address	MNE	Notes
Deselect (Nop)	H	X	X	X	X	NOP	1, 9
No Operation (Nop)	L	H	H	H	X	NOP	1, 9
Active (Select Bank And Activate Row)	L	L	H	H	Bank/Row	ACT	1, 3
Read (Select Bank And Column, And Start Read Burst)	L	H	L	H	Bank/Col	Read	1, 4
Write (Select Bank And Column, And Start Write Burst)	L	H	L	L	Bank/Col	Write	1, 4
Burst Terminate	L	H	H	L	X	BST	1, 8
Precharge (Deactivate Row In Bank Or Banks)	L	L	H	L	Code	PRE	1, 5
Auto Refresh Or Self Refresh (Enter Self Refresh Mode)	L	L	L	H	X	AR / SR	1, 6, 7
Mode Register Set	L	L	L	L	Op-Code	MRS	1, 2

1. CKE is HIGH for all commands shown except Self Refresh.
2. BA0, BA1 select either the Base or the Extended Mode Register (BA0 = 0, BA1 = 0 selects Mode Register; BA0 = 1, BA1 = 0 selects Extended Mode Register; other combinations of BA0-BA1 are reserved; A0-A12 provide the op-code to be written to the selected Mode Register.)
3. BA0-BA1 provide bank address and A0-A12 provide row address.
4. BA0, BA1 provide bank address; A0-A_i provide column address (where $i = 9$ for x8 and 9, 11 for x4); A10 HIGH enables the Auto Precharge feature (nonpersistent), A10 LOW disables the Auto Precharge feature.
5. A10 LOW: BA0, BA1 determine which bank is precharged.
A10 HIGH: all banks are precharged and BA0, BA1 are "Don't Care."
6. This command is AUTO REFRESH if CKE is HIGH; Self Refresh if CKE is LOW.
7. Internal refresh counter controls row and bank addressing; all inputs and I/Os are "Don't Care" except for CKE.
8. Applies only to read bursts with Auto Precharge disabled; this command is undefined (and should not be used) for read bursts with Auto Precharge enabled or for write bursts
9. Deselect and NOP are functionally interchangeable.

Truth Table 1b: DM Operation

Name (Function)	DM	DQs	Notes
Write Enable	L	Valid	1
Write Inhibit	H	X	1

1. Used to mask write data; provided coincident with the corresponding data.

Deselect

The Deselect function prevents new commands from being executed by the DDR SDRAM. The DDR SDRAM is effectively deselected. Operations already in progress are not affected.

No Operation (NOP)

The No Operation (NOP) command is used to perform a NOP to a DDR SDRAM. This prevents unwanted commands from being registered during idle or wait states. Operations already in progress are not affected.

Mode Register Set

The mode registers are loaded via inputs A0-A12, BA0 and BA1. See mode register descriptions in the Register Definition section. The Mode Register Set command can only be issued when all banks are idle and no bursts are in progress. A subsequent executable command cannot be issued until t_{MRD} is met.

Active

The Active command is used to open (or activate) a row in a particular bank for a subsequent access. The value on the BA0, BA1 inputs selects the bank, and the address provided on inputs A0-A12 selects the row. This row remains active (or open) for accesses until a Precharge (or Read or Write with Auto Precharge) is issued to that bank. A Precharge (or Read or Write with Auto Precharge) command must be issued and completed before opening a different row in the same bank.

Read

The Read command is used to initiate a burst read access to an active (open) row. The value on the BA0, BA1 inputs selects the bank, and the address provided on inputs A0-A_i, A_j (where [i = 9, j = don't care] for x8; where [i = 9, j = 11] for x4) selects the starting column location. The value on input A10 determines whether or not Auto Precharge is used. If Auto Precharge is selected, the row being accessed is precharged at the end of the Read burst; if Auto Precharge is not selected, the row remains open for subsequent accesses.

Write

The Write command is used to initiate a burst write access to an active (open) row. The value on the BA0, BA1 inputs selects the bank, and the address provided on inputs A0-A_i, A_j (where [i = 9, j = don't care] for x8; where [i = 9, j = 11] for x4) selects the starting column location. The value on input A10 determines whether or not Auto Precharge is used. If Auto Precharge is selected, the row being accessed is precharged at the end of the Write burst; if Auto Precharge is not selected, the row remains open for subsequent accesses. Input data appearing on the DQs is written to the memory array subject to the DM input logic level appearing coincident with the data. If a given DM signal is registered low, the corresponding data is written to memory; if the DM signal is registered high, the corresponding data inputs are ignored, and a Write is not executed to that byte/column location.

Precharge

The Precharge command is used to deactivate (close) the open row in a particular bank or the open row(s) in all banks. The bank(s) will be available for a subsequent row access a specified time (t_{RP}) after the Precharge command is issued. Input A10 determines whether one or all banks are to be precharged, and in the case where only one bank is to be precharged, inputs BA0, BA1 select the bank. Otherwise BA0, BA1 are treated as "Don't Care." Once a bank has been precharged, it is in the idle state and must be activated prior to any Read or Write commands being issued to that bank. A precharge command is treated as a NOP if there is no open row in that bank, or if the previously open row is already in the process of precharging.

Auto Precharge

Auto Precharge is a feature which performs the same individual-bank precharge function described above, but without requiring an explicit command. This is accomplished by using A10 to enable Auto Precharge in conjunction with a specific Read or Write command. A precharge of the bank/row that is addressed with the Read or Write command is automatically performed upon completion of the Read or Write burst. Auto Precharge is nonpersistent in that it is either enabled or disabled for each individual Read or Write command. Auto Precharge ensures that the precharge is initiated at the earliest valid stage within a burst. The user must not issue another command to the same bank until the precharge (t_{RP}) is completed. This is determined as if an explicit Precharge command was issued at the earliest possible time, as described for each burst type in the Operation section of this data sheet.

Burst Terminate

The Burst Terminate command is used to truncate read bursts (with Auto Precharge disabled). The most recently registered Read command prior to the Burst Terminate command is truncated, as shown in the Operation section of this data sheet.

Auto Refresh

Auto Refresh is used during normal operation of the DDR SDRAM and is analogous to CAS Before RAS (CBR) Refresh in previous DRAM types. This command is nonpersistent, so it must be issued each time a refresh is required.

The refresh addressing is generated by the internal refresh controller. This makes the address bits “Don’t Care” during an Auto Refresh command. The 256Mb DDR SDRAM requires Auto Refresh cycles at an average periodic interval of 7.8 μ s (maximum).

To allow for improved efficiency in scheduling and switching between tasks, some flexibility in the absolute refresh interval is provided. A maximum of eight Auto Refresh commands can be posted in the system, meaning that the maximum absolute interval between any Auto Refresh command and the next Auto Refresh command is $9 * 7.8 \mu\text{s}$ (70.2 μ s). This maximum absolute interval is short enough to allow for DLL updates internal to the DDR SDRAM to be restricted to Auto Refresh cycles, without allowing too much drift in t_{AC} between updates.

Self Refresh

The Self Refresh command can be used to retain data in the DDR SDRAM, even if the rest of the system is powered down. When in the self refresh mode, the DDR SDRAM retains data without external clocking. The Self Refresh command is initiated as an Auto Refresh command coincident with CKE transitioning low. The DLL is automatically disabled upon entering Self Refresh, and is automatically enabled upon exiting Self Refresh (200 clock cycles must then occur before a Read command can be issued). Input signals except CKE (low) are “Don’t Care” during Self Refresh operation.

The procedure for exiting self refresh requires a sequence of commands. CK (and \overline{CK}) must be stable prior to CKE returning high. Once CKE is high, the SDRAM must have NOP commands issued for t_{XSNR} because time is required for the completion of any internal refresh in progress. A simple algorithm for meeting both refresh and DLL requirements is to apply NOPs for 200 clock cycles before applying any other command.

Operations

Bank/Row Activation

Before any Read or Write commands can be issued to a bank within the DDR SDRAM, a row in that bank must be "opened" (activated). This is accomplished via the Active command and addresses A0-A12, BA0 and BA1 (see Activating a Specific Row in a Specific Bank), which decode and select both the bank and the row to be activated. After opening a row (issuing an Active command), a Read or Write command may be issued to that row, subject to the t_{RCD} specification. A subsequent Active command to a different row in the same bank can only be issued after the previous active row has been "closed" (precharged). The minimum time interval between successive Active commands to the same bank is defined by t_{RC} . A subsequent Active command to another bank can be issued while the first bank is being accessed, which results in a reduction of total row-access overhead. The minimum time interval between successive Active commands to different banks is defined by t_{RRD} .

Activating a Specific Row in a Specific Bank

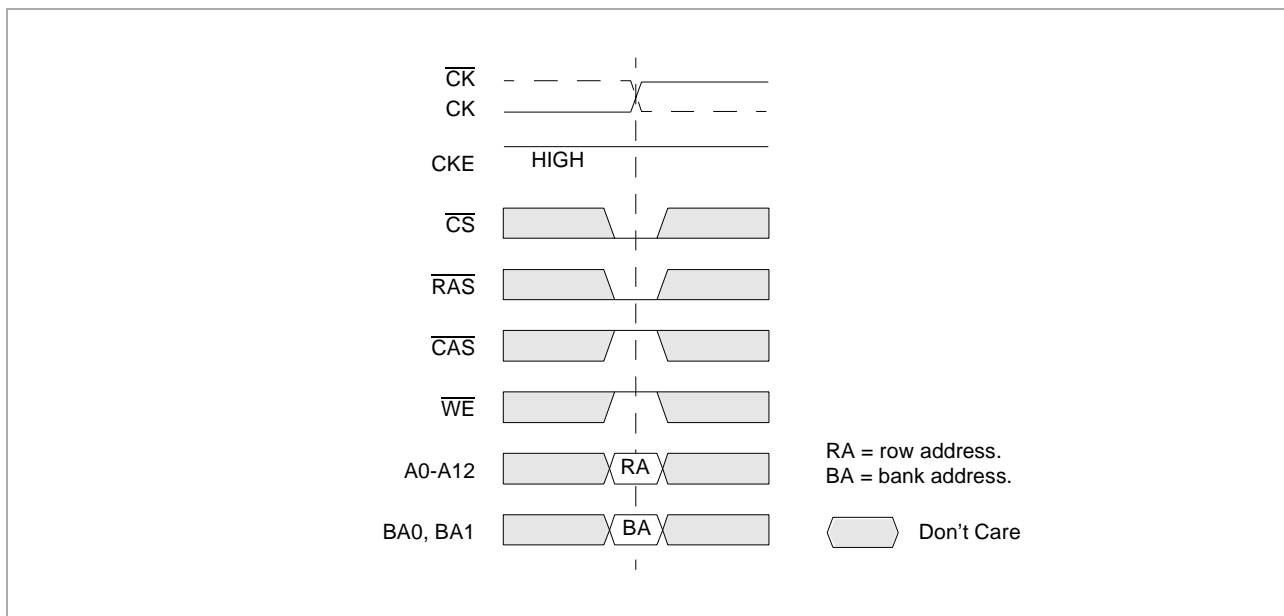

t_{RCD} and t_{RRD} Definition

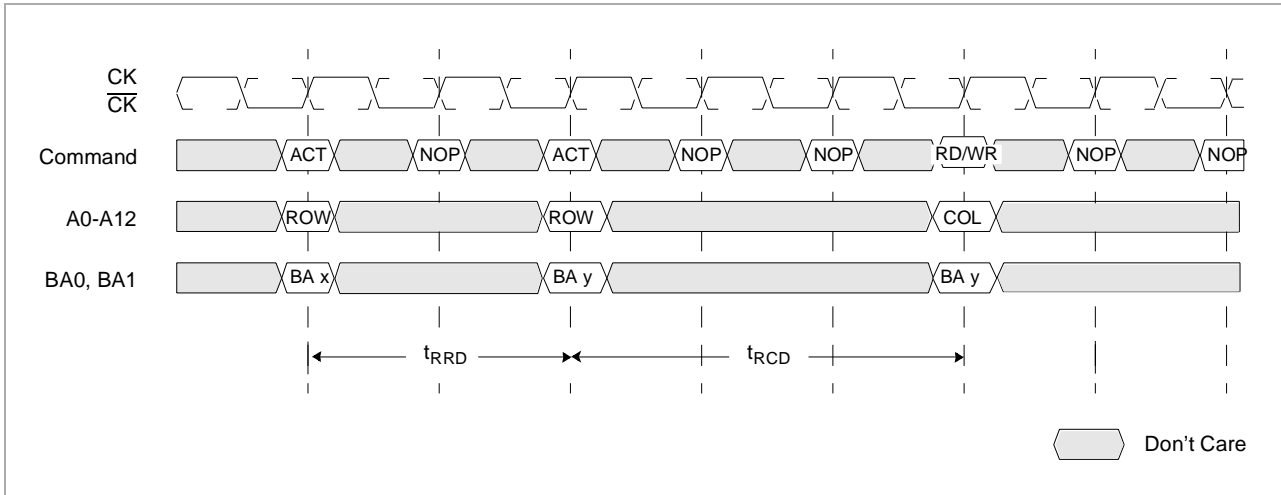

Reads

Subsequent to programming the mode register with CAS latency, burst type, and burst length, Read bursts are initiated with a Read command, as shown on *Read Command* on page 19.

The starting column and bank addresses are provided with the Read command and Auto Precharge is either enabled or disabled for that burst access. If Auto Precharge is enabled, the row that is accessed starts pre-charge at the completion of the burst, provided t_{RAS} has been satisfied. For the generic Read commands used in the following illustrations, Auto Precharge is disabled.

During Read bursts, the valid data-out element from the starting column address is available following the CAS latency after the Read command. Each subsequent data-out element is valid nominally at the next positive or negative clock edge (i.e. at the next crossing of CK and \overline{CK}). *Read Burst: CAS Latencies (Burst Length = 4)* on page 20 shows general timing for each supported CAS latency setting. DQS is driven by the DDR SDRAM along with output data. The initial low state on DQS is known as the read preamble; the low state coincident with the last data-out element is known as the read postamble. Upon completion of a burst, assuming no other commands have been initiated, the DQs goes High-Z. Data from any Read burst may be concatenated with or truncated with data from a subsequent Read command. In either case, a continuous flow of data can be maintained. The first data element from the new burst follows either the last element of a completed burst or the last desired data element of a longer burst which is being truncated. The new Read command should be issued x cycles after the first Read command, where x equals the number of desired data element pairs (pairs are required by the $2n$ prefetch architecture). This is shown on *Consecutive Read Bursts: CAS Latencies (Burst Length = 4 or 8)* on page 21. A Read command can be initiated on any clock cycle following a previous Read command. Nonconsecutive Read data is illustrated on *Non-Consecutive Read Bursts: CAS Latencies (Burst Length = 4)* on page 22. Full-speed Random Read Accesses: CAS Latencies (Burst Length = 2, 4 or 8) within a page (or pages) can be performed as shown on page 23.

Read Command

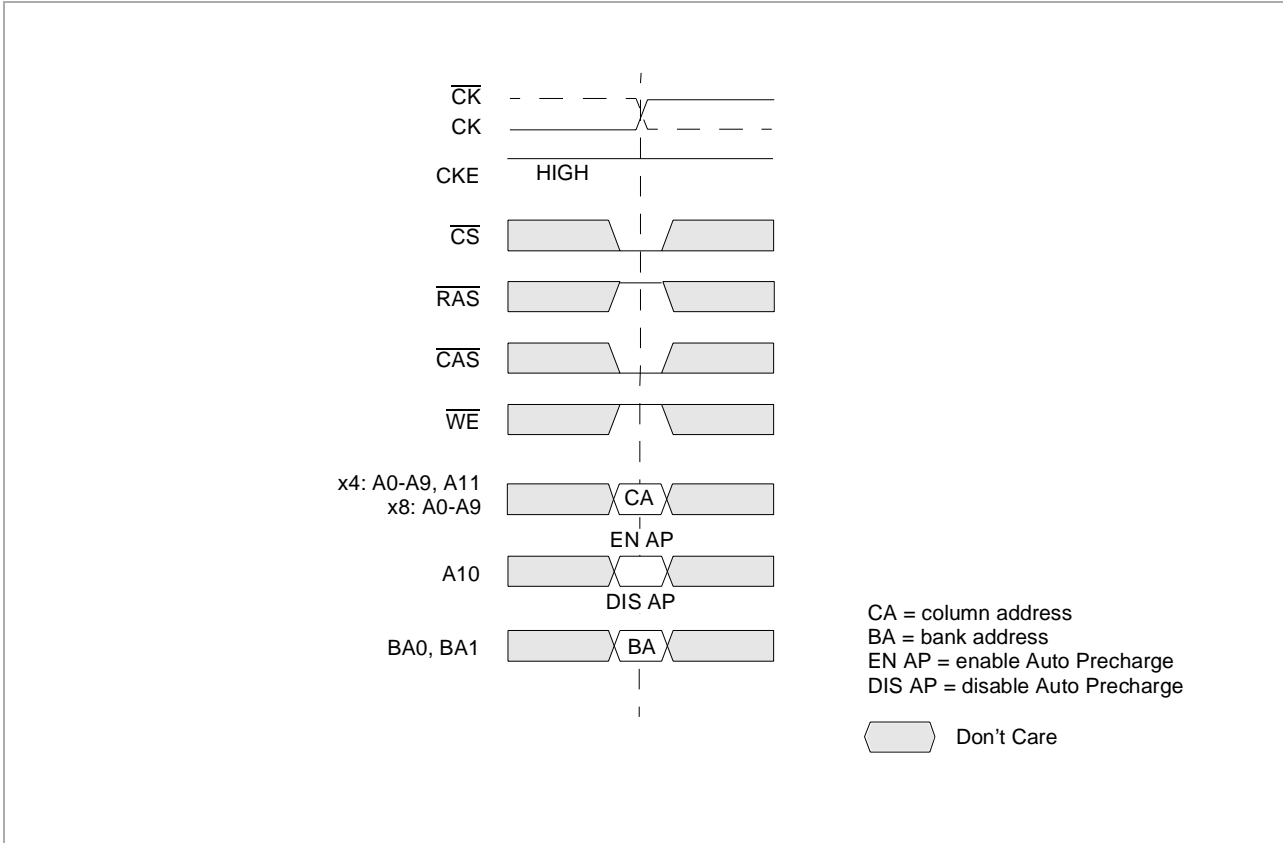

Read Burst: CAS Latencies (Burst Length = 4)

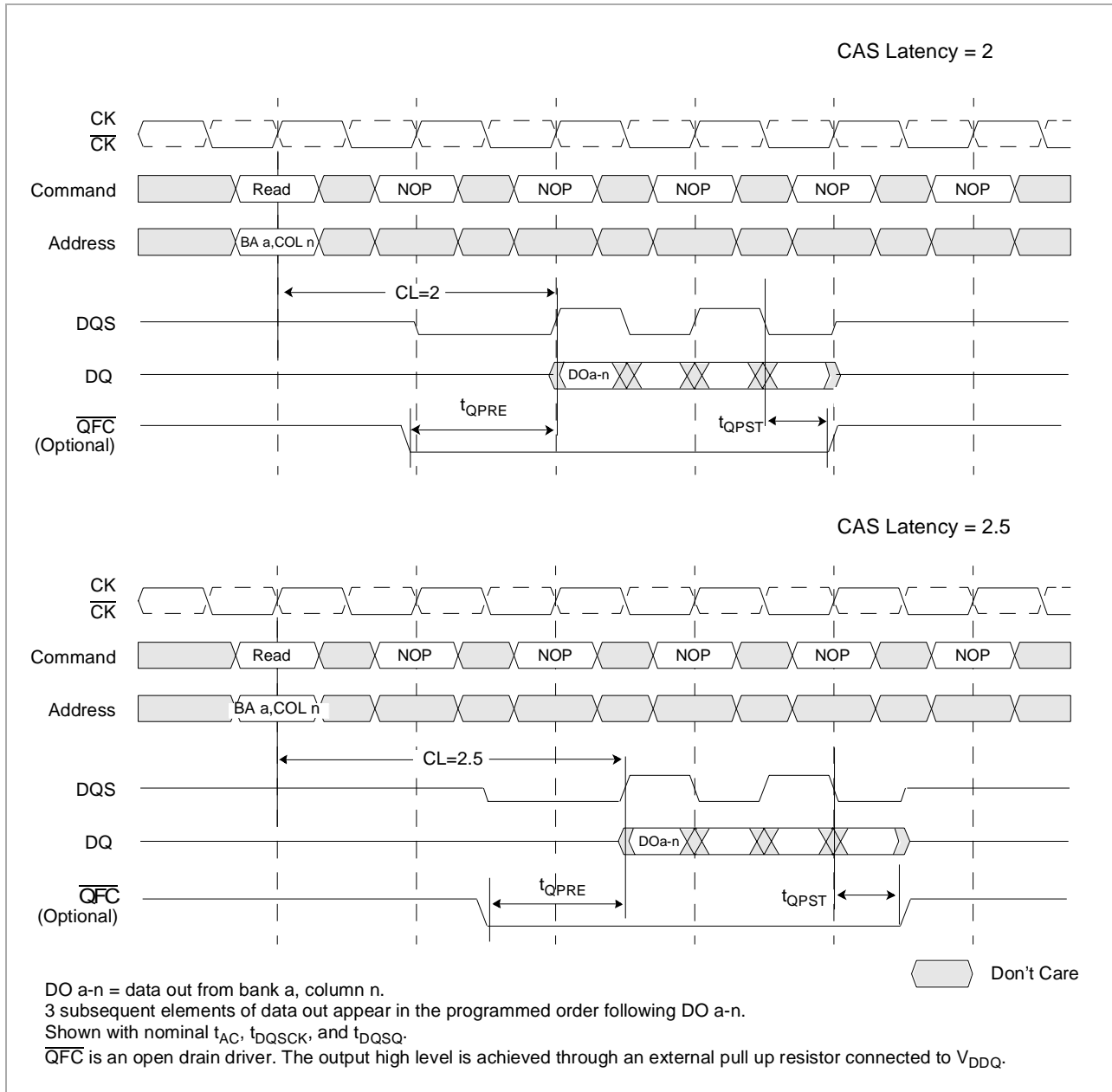

Consecutive Read Bursts: CAS Latencies (Burst Length = 4 or 8)

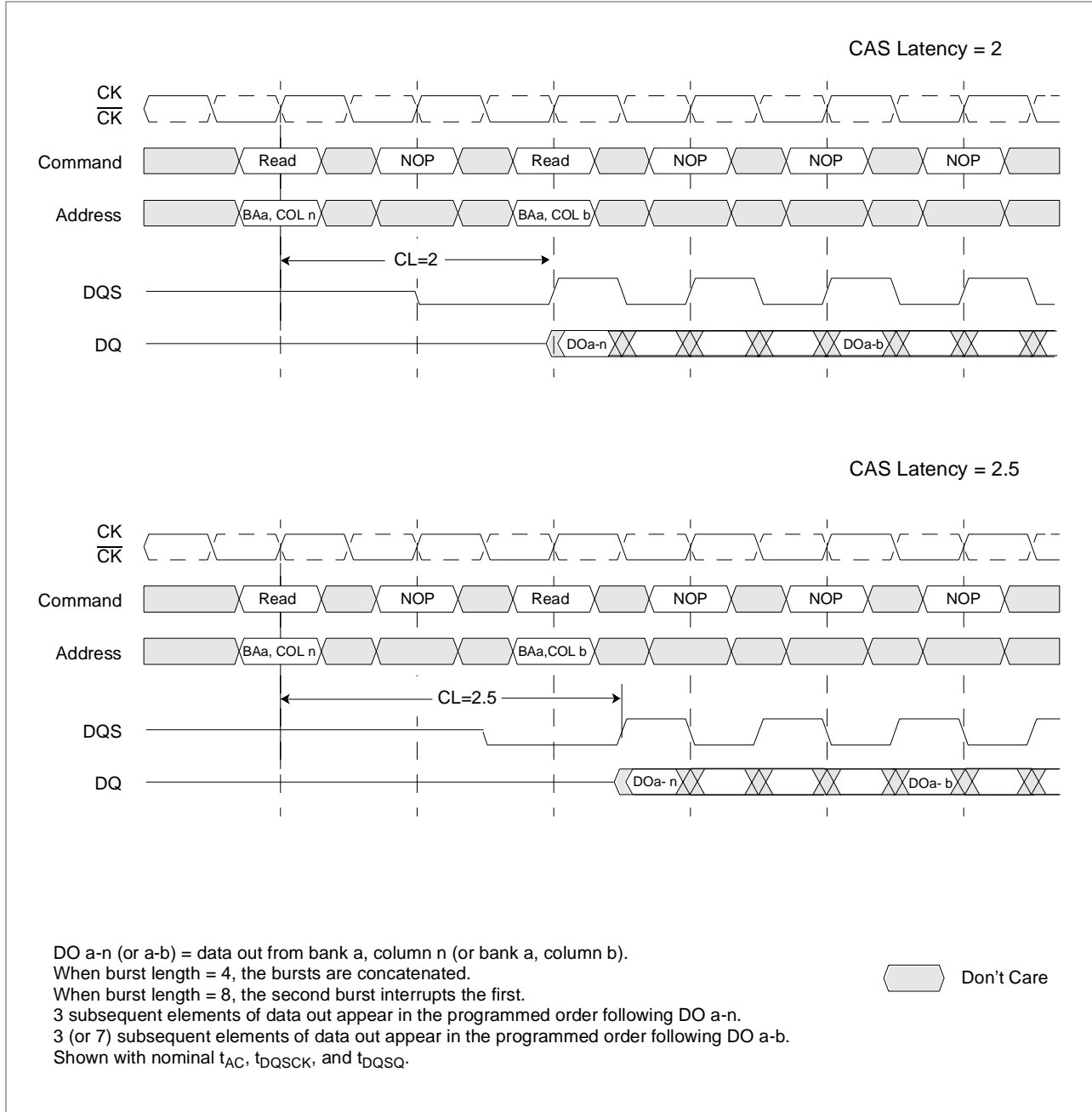

Non-Consecutive Read Bursts: CAS Latencies (Burst Length = 4)

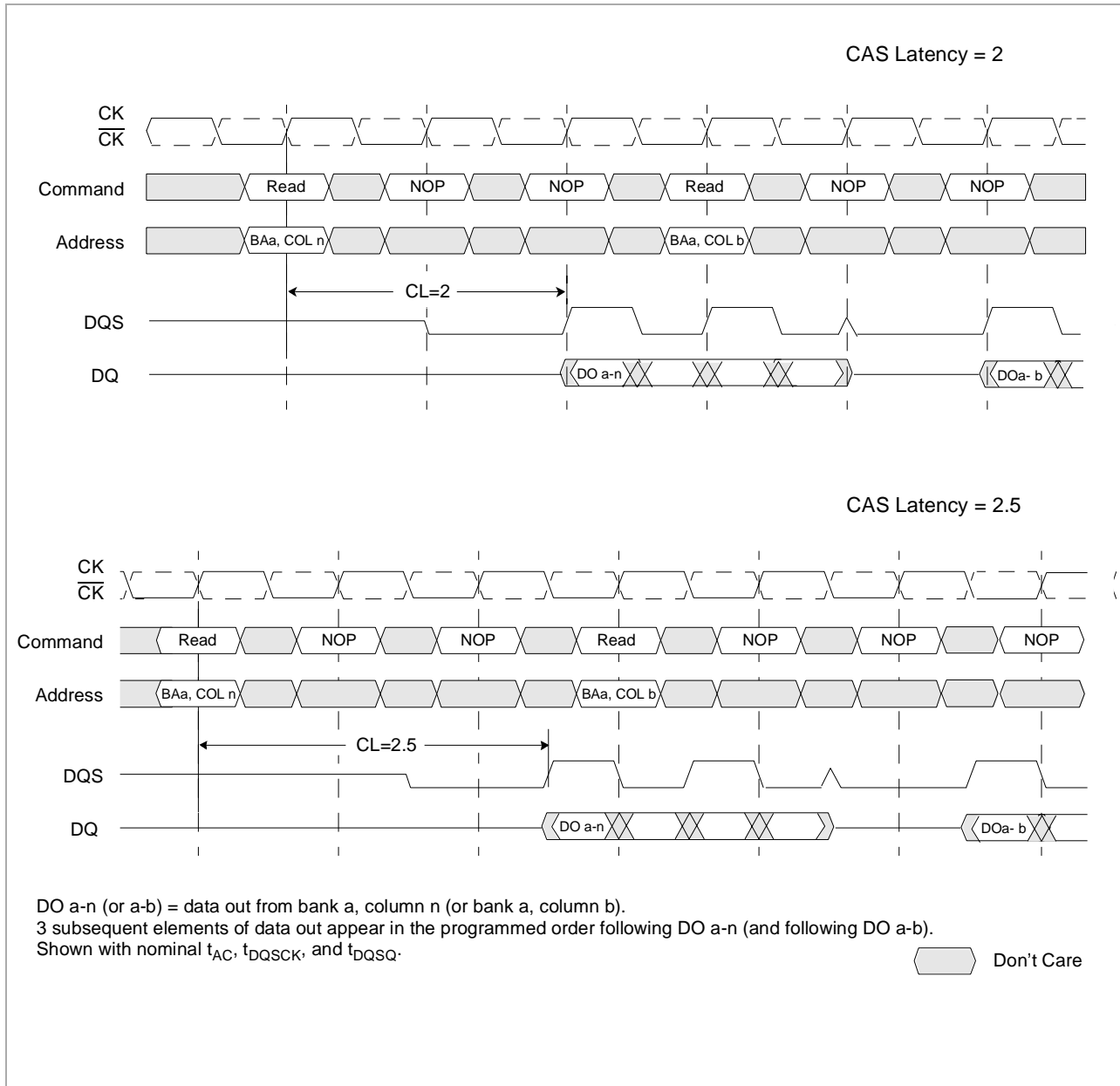

Random Read Accesses: CAS Latencies (Burst Length = 2, 4 or 8)

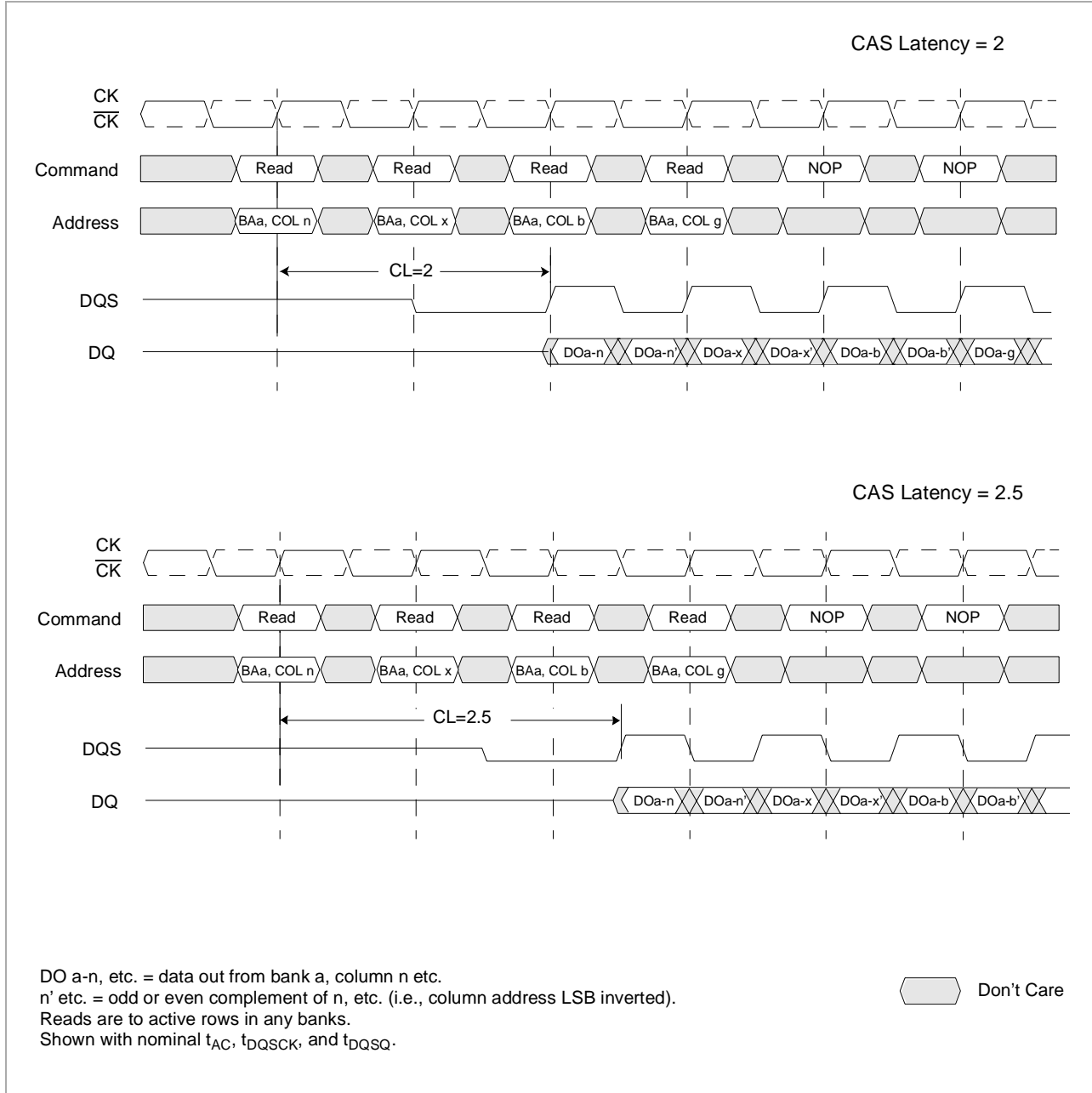

Data from any Read burst may be truncated with a Burst Terminate command, as shown on *Terminating a Read Burst: CAS Latencies (Burst Length = 8)* on page 25. The Burst Terminate latency is equal to the read (CAS) latency, i.e. the Burst Terminate command should be issued x cycles after the Read command, where x equals the number of desired data element pairs.

Data from any Read burst must be completed or truncated before a subsequent Write command can be issued. If truncation is necessary, the Burst Terminate command must be used, as shown on *Read to Write: CAS Latencies (Burst Length = 4 or 8)* on page 26. The example is shown for $t_{DQSS}(\text{min})$. The $t_{DQSS}(\text{max})$ case, not shown here, has a longer bus idle time. $t_{DQSS}(\text{min})$ and $t_{DQSS}(\text{max})$ are defined in the section on Writes.

A Read burst may be followed by, or truncated with, a Precharge command to the same bank (provided that Auto Precharge was not activated). The Precharge command should be issued x cycles after the Read command, where x equals the number of desired data element pairs (pairs are required by the $2n$ prefetch architecture). This is shown on *Read to Precharge: CAS Latencies (Burst Length = 4 or 8)* on page 27 for Read latencies of 2 and 2.5. Following the Precharge command, a subsequent command to the same bank cannot be issued until t_{RP} is met. Note that part of the row precharge time is hidden during the access of the last data elements.

In the case of a Read being executed to completion, a Precharge command issued at the optimum time (as described above) provides the same operation that would result from the same Read burst with Auto Precharge enabled. The disadvantage of the Precharge command is that it requires that the command and address busses be available at the appropriate time to issue the command. The advantage of the Precharge command is that it can be used to truncate bursts.

Terminating a Read Burst: CAS Latencies (Burst Length = 8)

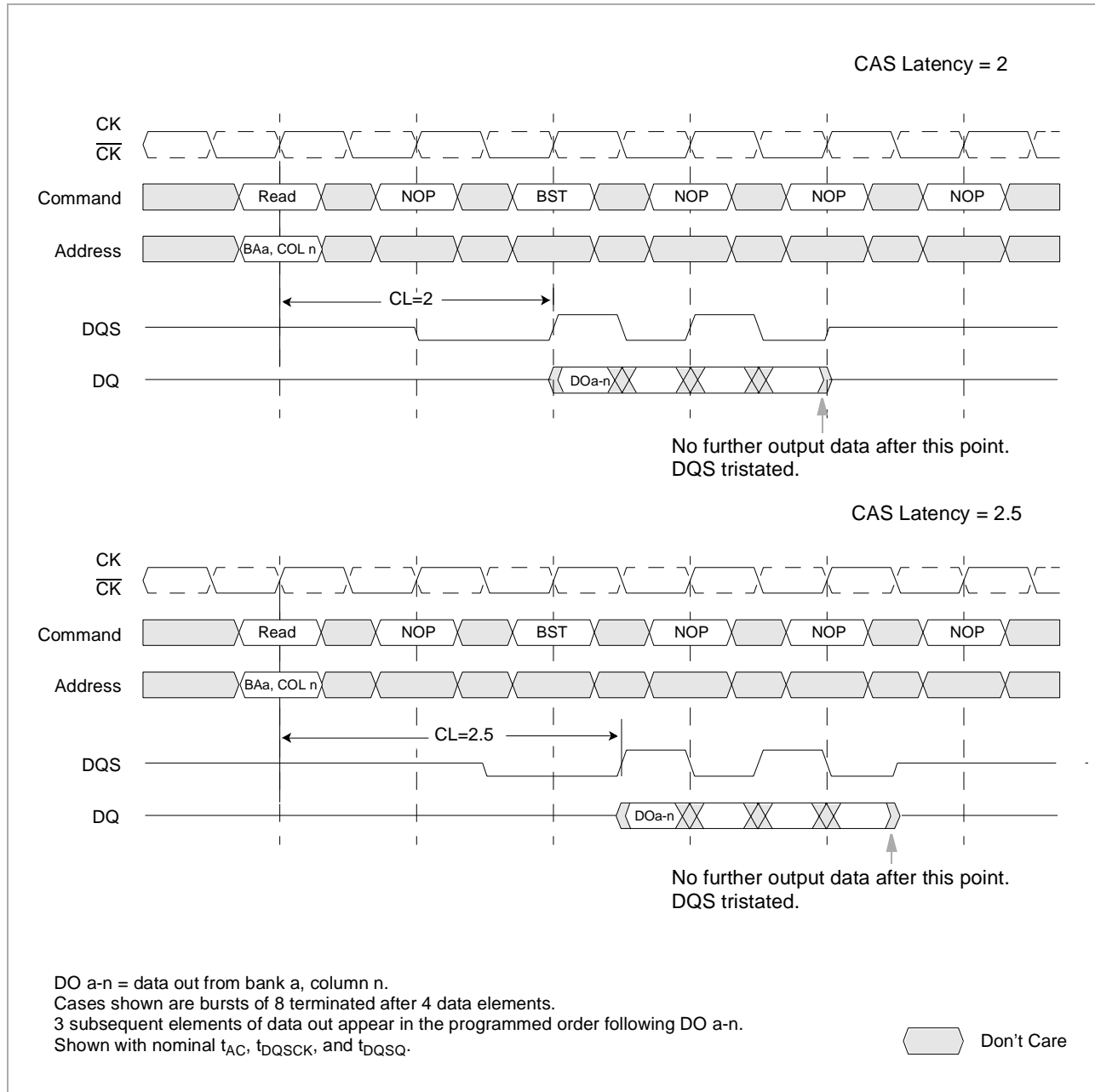

Read to Write: CAS Latencies (Burst Length = 4 or 8)

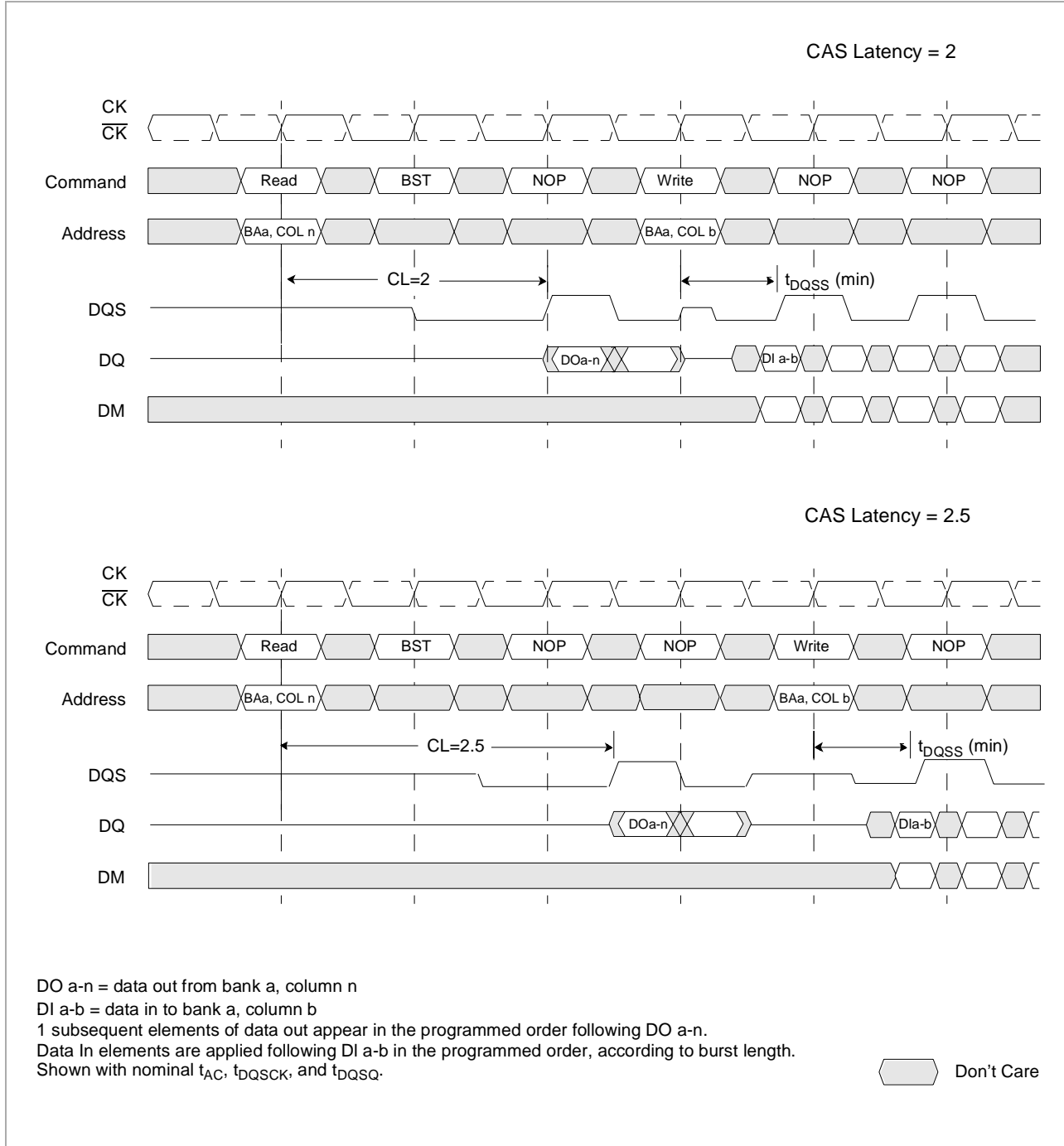

Read to Precharge: CAS Latencies (Burst Length = 4 or 8)

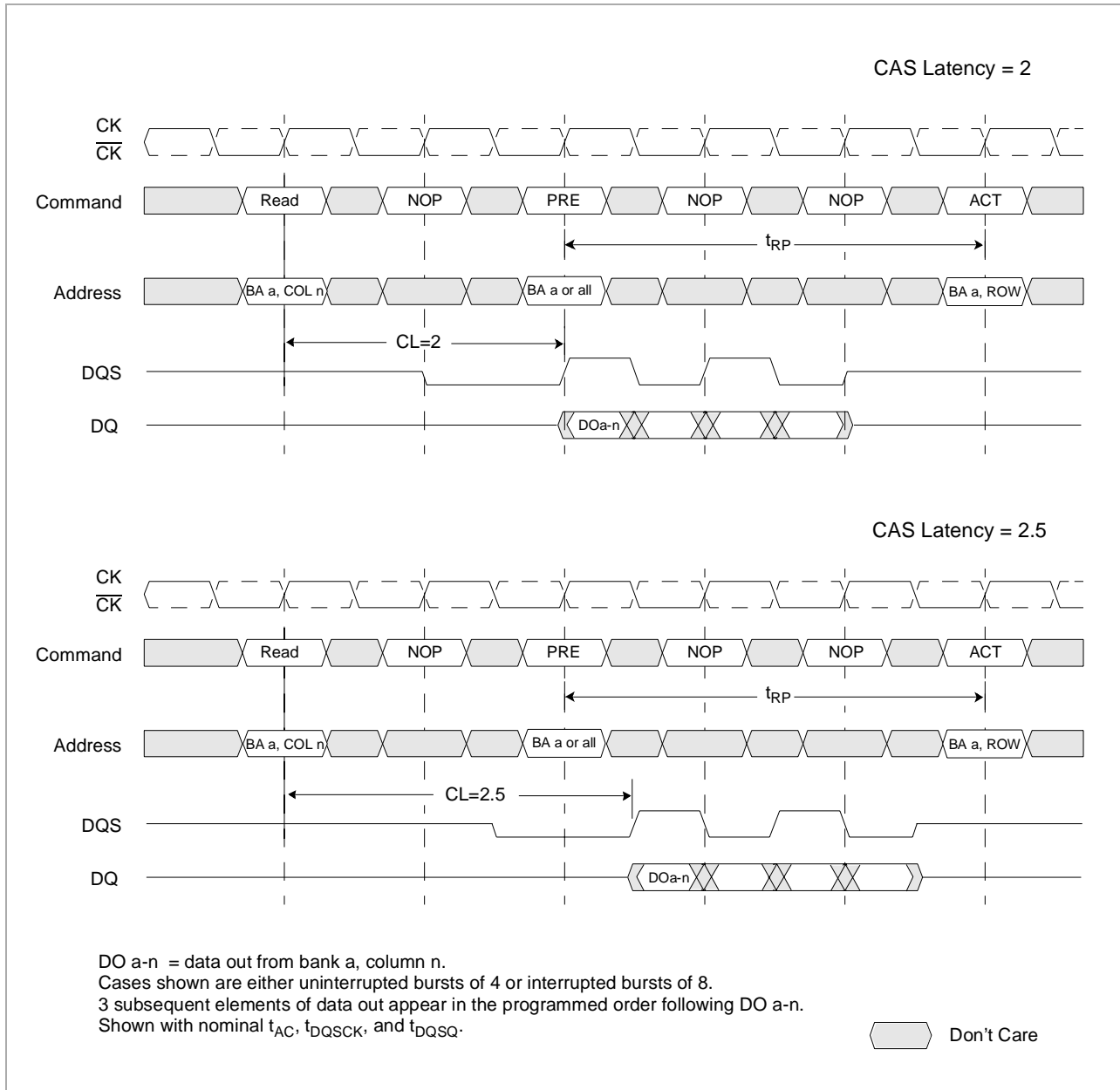

Writes

Write bursts are initiated with a Write command, as shown on *Write Command* on page 29.

The starting column and bank addresses are provided with the Write command, and Auto Precharge is either enabled or disabled for that access. If Auto Precharge is enabled, the row being accessed is precharged at the completion of the burst. For the generic Write commands used in the following illustrations, Auto Precharge is disabled.

During Write bursts, the first valid data-in element is registered on the first rising edge of DQS following the write command, and subsequent data elements are registered on successive edges of DQS. The Low state on DQS between the Write command and the first rising edge is known as the write preamble; the Low state on DQS following the last data-in element is known as the write postamble. The time between the Write command and the first corresponding rising edge of DQS (t_{DQSS}) is specified with a relatively wide range (from 75% to 125% of one clock cycle), so most of the Write diagrams that follow are drawn for the two extreme cases (i.e. $t_{DQSS}(\min)$ and $t_{DQSS}(\max)$). *Write Burst (Burst Length = 4)* on page 30 shows the two extremes of t_{DQSS} for a burst of four. Upon completion of a burst, assuming no other commands have been initiated, the DQs and DQS enters High-Z and any additional input data is ignored.

Data for any Write burst may be concatenated with or truncated with a subsequent Write command. In either case, a continuous flow of input data can be maintained. The new Write command can be issued on any positive edge of clock following the previous Write command. The first data element from the new burst is applied after either the last element of a completed burst or the last desired data element of a longer burst which is being truncated. The new Write command should be issued x cycles after the first Write command, where x equals the number of desired data element pairs (pairs are required by the $2n$ prefetch architecture). *Write to Write (Burst Length = 4)* on page 31 shows concatenated bursts of 4. An example of non-consecutive Writes is shown on *Write to Write: Max DQSS, Non-Consecutive (Burst Length = 4)* on page 32. Full-speed random write accesses within a page or pages can be performed as shown on *Random Write Cycles (Burst Length = 2, 4 or 8)* on page 33. Data for any Write burst may be followed by a subsequent Read command. To follow a Write without truncating the write burst, t_{WTR} (Write to Read) should be met as shown on *Write to Read: Non-Interrupting (CAS Latency = 2; Burst Length = 4)* on page 34.

Data for any Write burst may be truncated by a subsequent Read command, as shown in the figures on *Write to Read: Interrupting (CAS Latency = 2; Burst Length = 8)* on page 35 to *Write to Read: Nominal DQSS, Interrupting (CAS Latency = 2; Burst Length = 8)* on page 37. Note that only the data-in pairs that are registered prior to the t_{WTR} period are written to the internal array, and any subsequent data-in must be masked with DM, as shown in the diagrams noted previously.

Data for any Write burst may be followed by a subsequent Precharge command. To follow a Write without truncating the write burst, t_{WR} should be met as shown on *Write to Precharge: Non-Interrupting (Burst Length = 4)* on page 38.

Data for any Write burst may be truncated by a subsequent Precharge command, as shown in the figures on *Write to Precharge: Interrupting (Burst Length = 4 or 8)* on page 39 to *Write to Precharge: Nominal DQSS (2 bit Write), Interrupting (Burst Length = 4 or 8)* on page 41. Note that only the data-in pairs that are registered prior to the t_{WR} period are written to the internal array, and any subsequent data in should be masked with DM. Following the Precharge command, a subsequent command to the same bank cannot be issued until t_{RP} is met.

In the case of a Write burst being executed to completion, a Precharge command issued at the optimum time (as described above) provides the same operation that would result from the same burst with Auto Precharge. The disadvantage of the Precharge command is that it requires that the command and address buses be available at the appropriate time to issue the command. The advantage of the Precharge command is that it can be used to truncate bursts.

Write Command

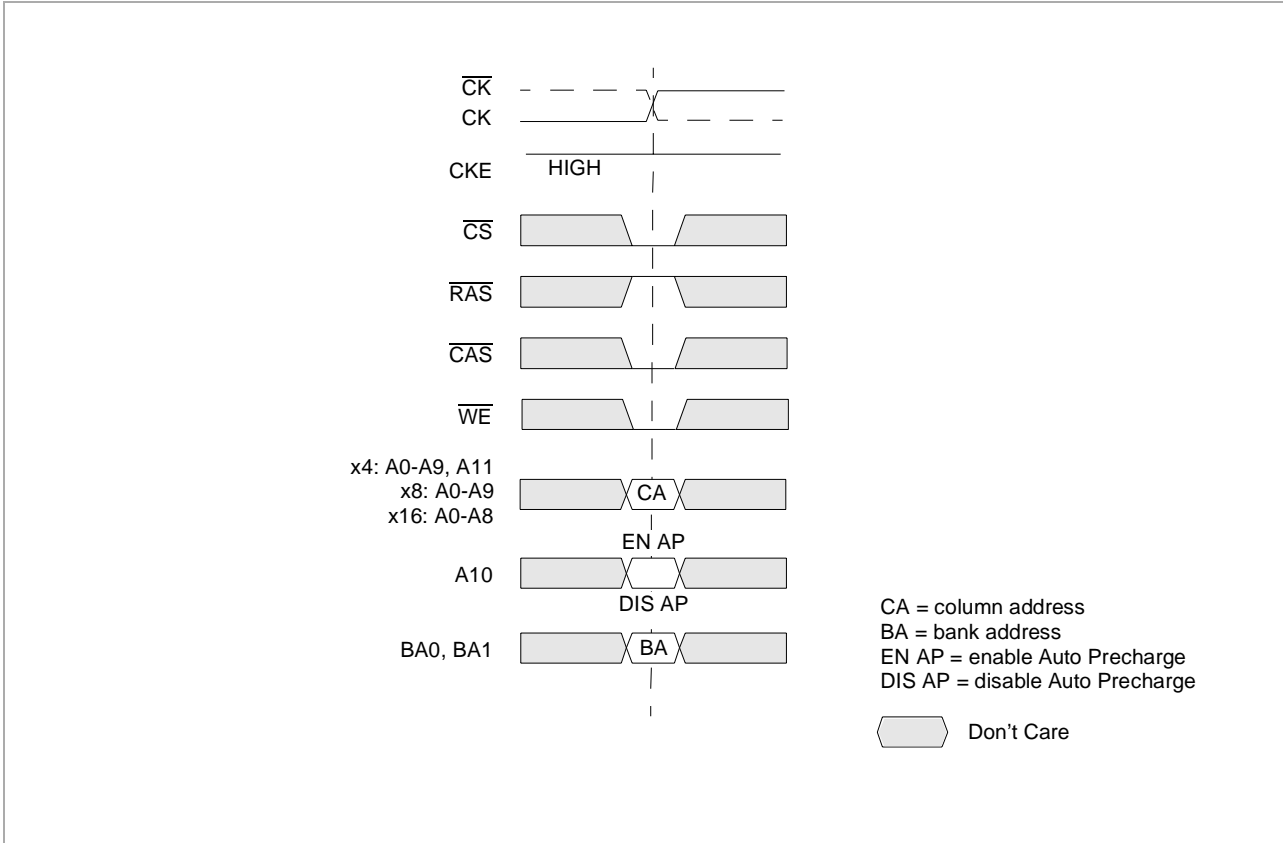

Write Burst (Burst Length = 4)

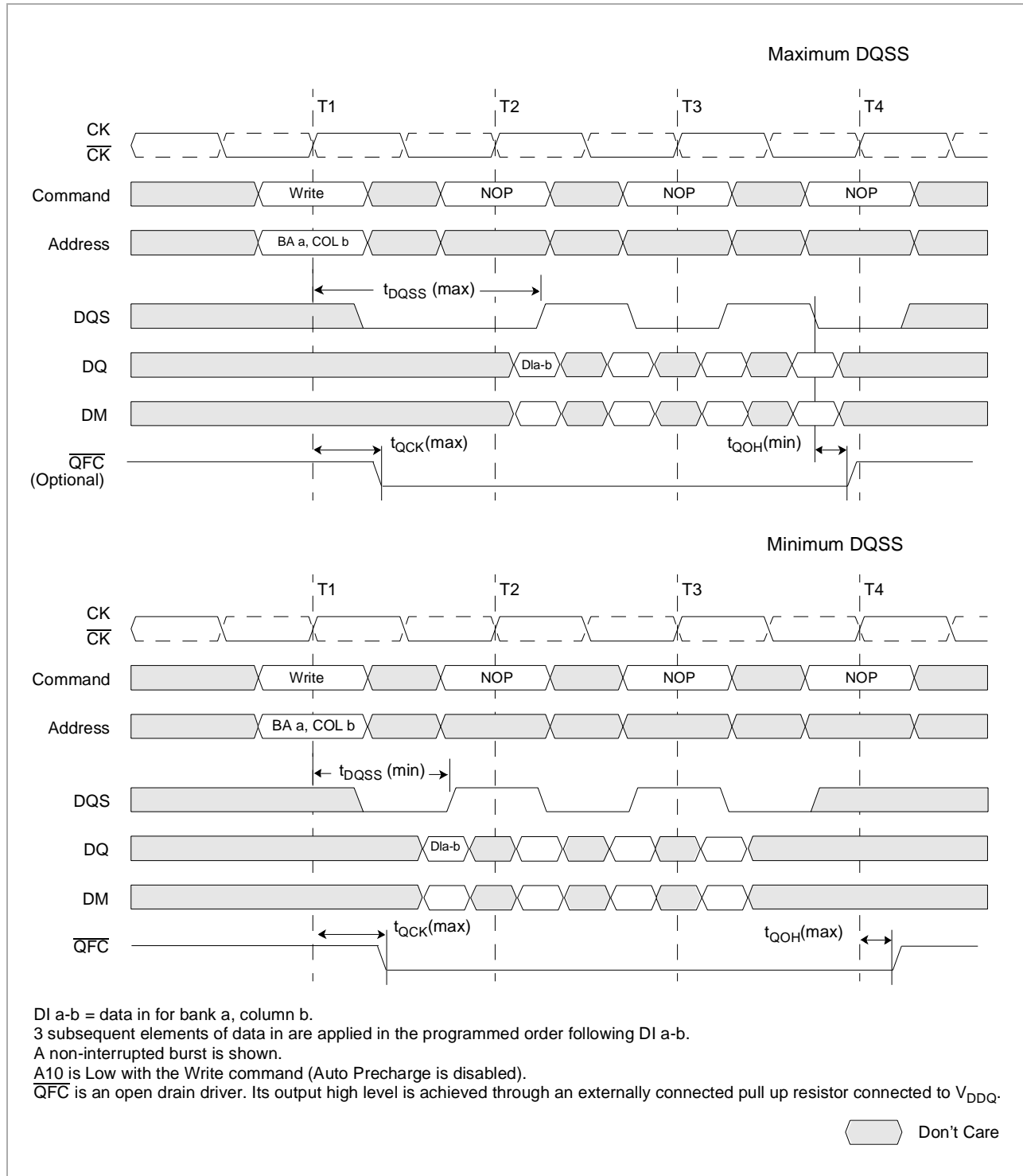

Write to Write (Burst Length = 4)

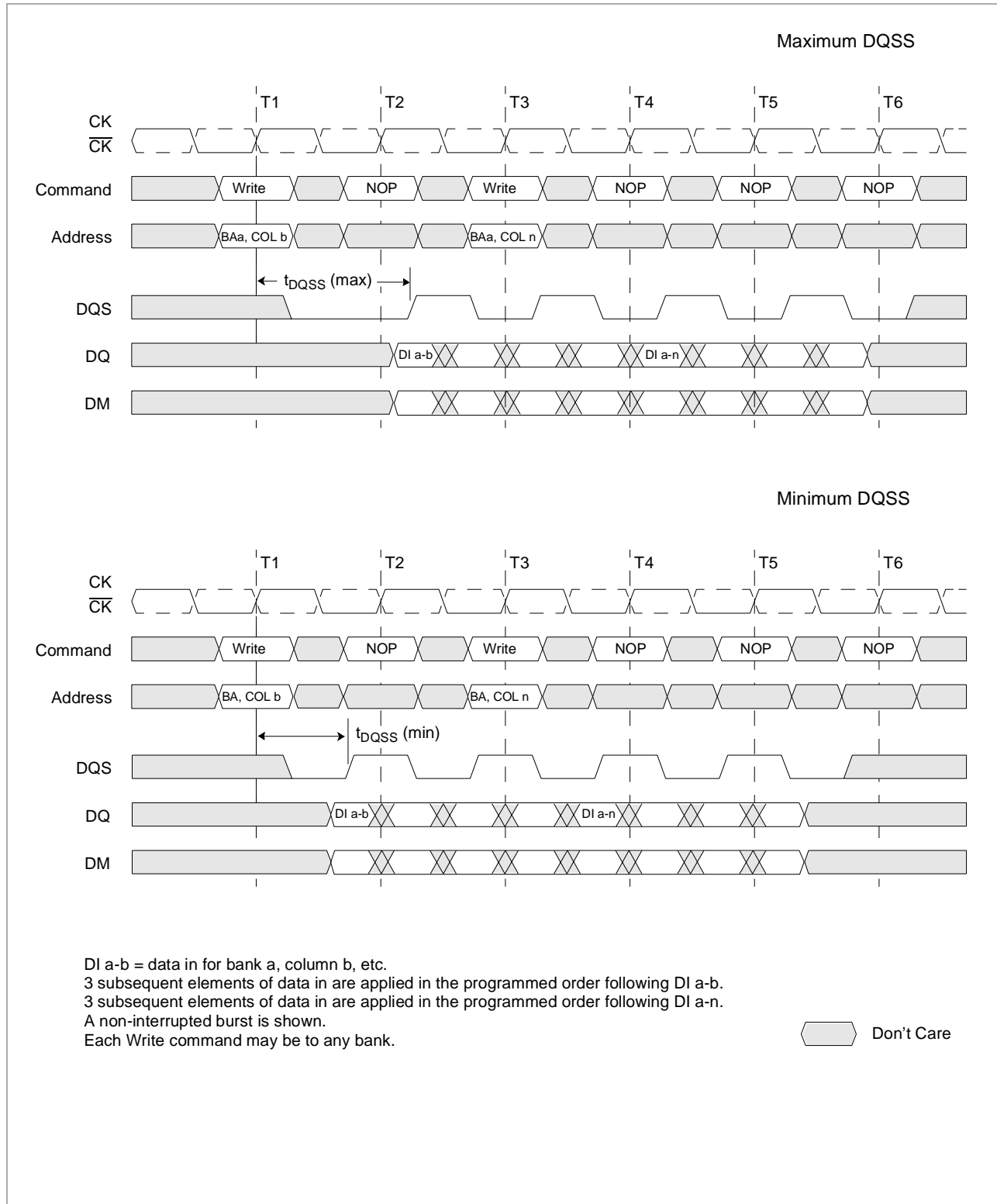

Write to Write: Max DQSS, Non-Consecutive (Burst Length = 4)

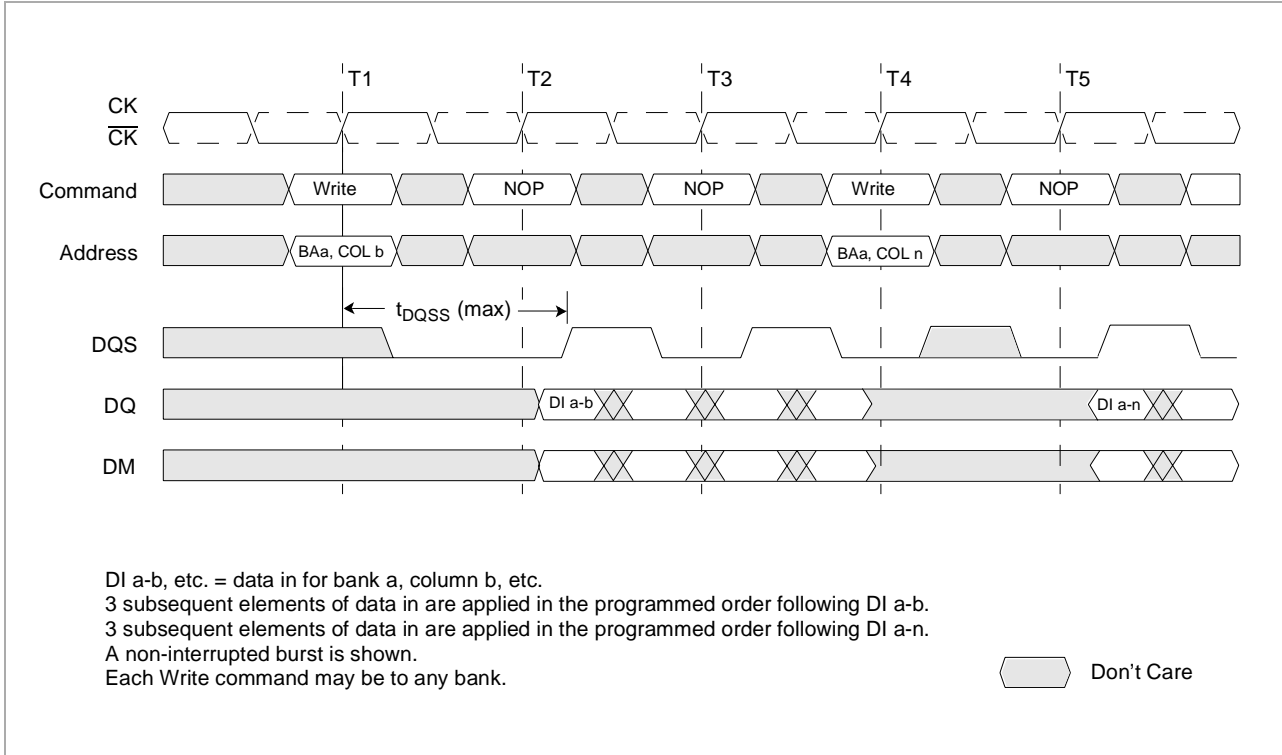

Random Write Cycles (Burst Length = 2, 4 or 8)

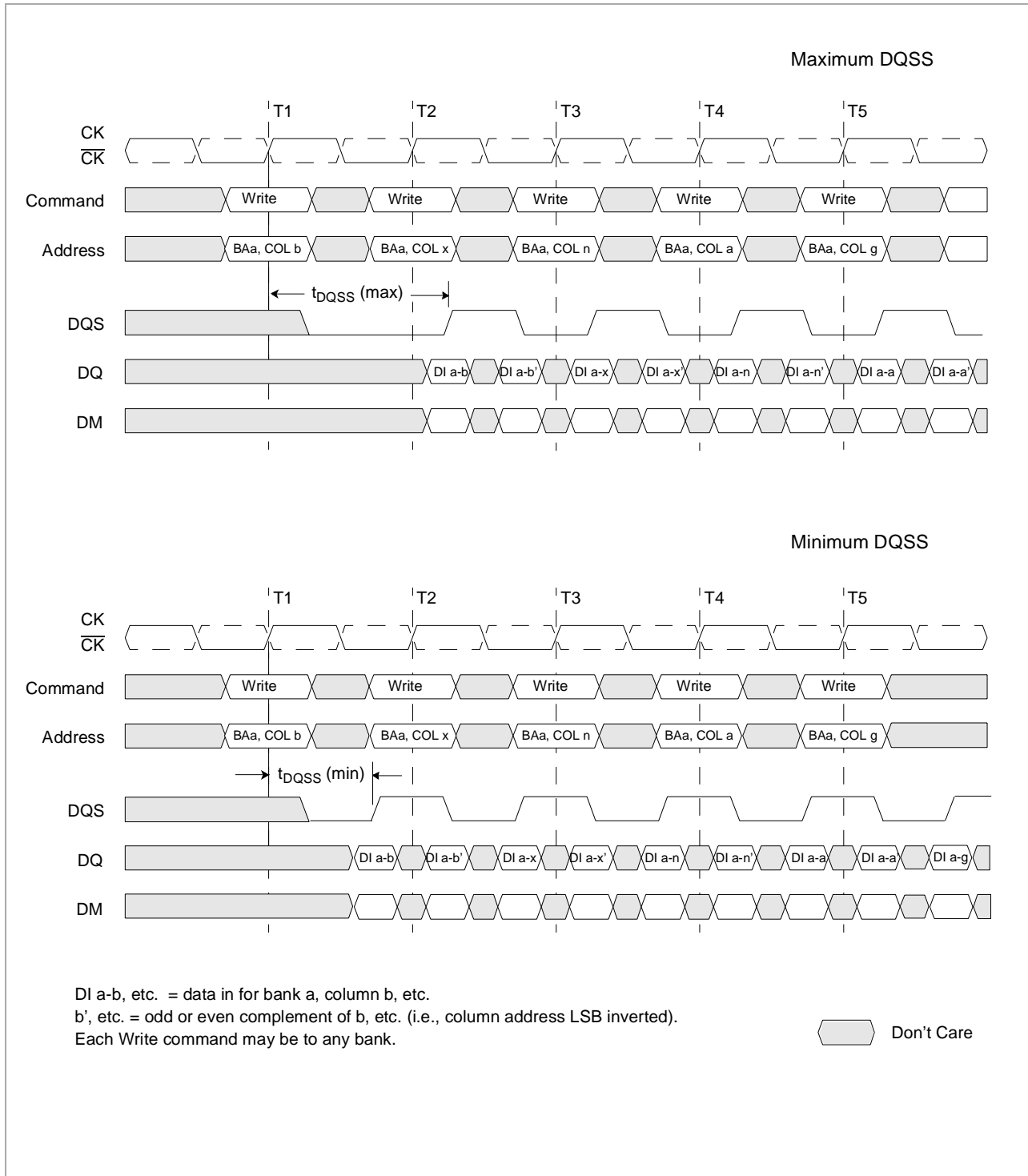

Write to Read: Non-Interrupting (CAS Latency = 2; Burst Length = 4)

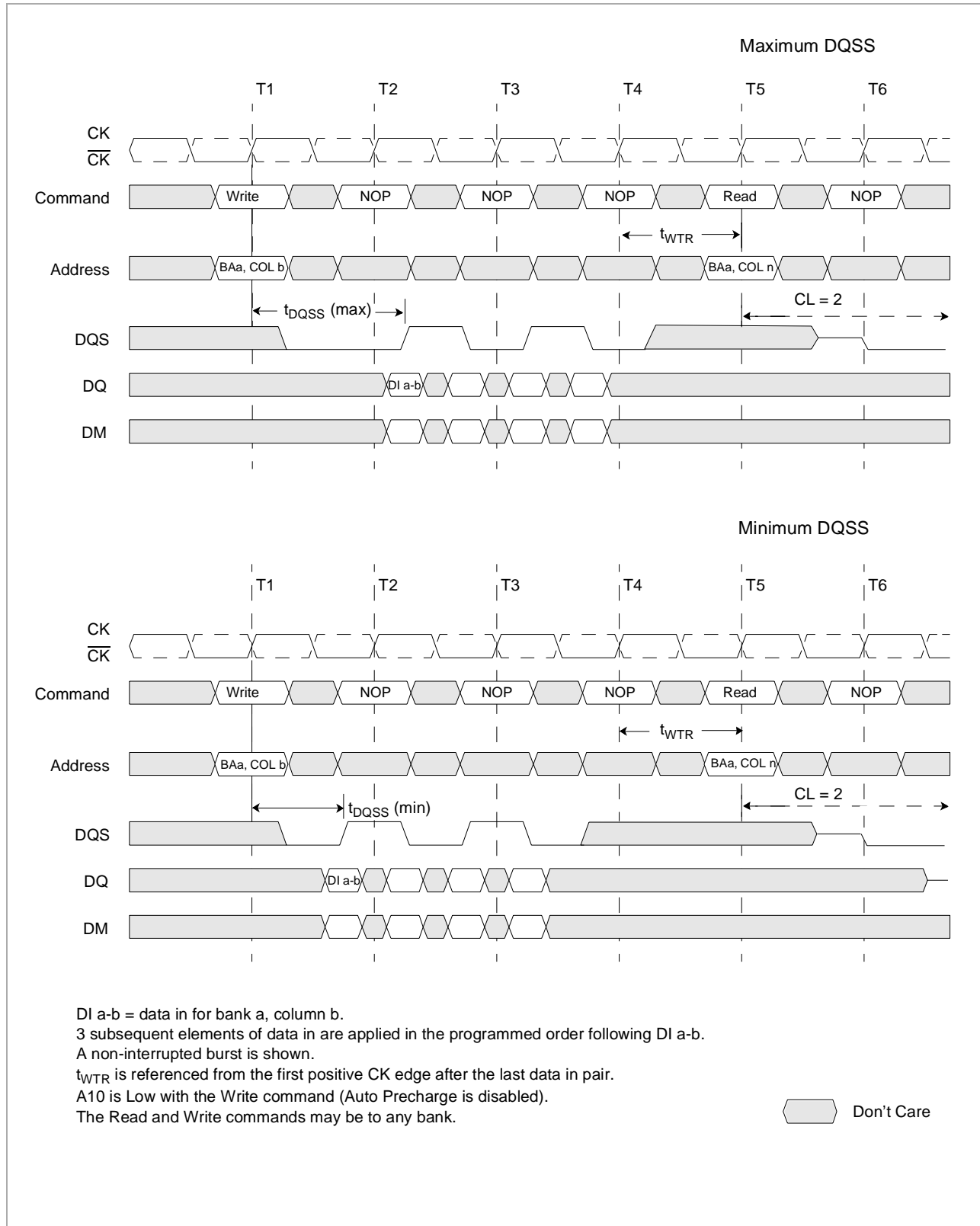

Write to Read: Interrupting (CAS Latency = 2; Burst Length = 8)

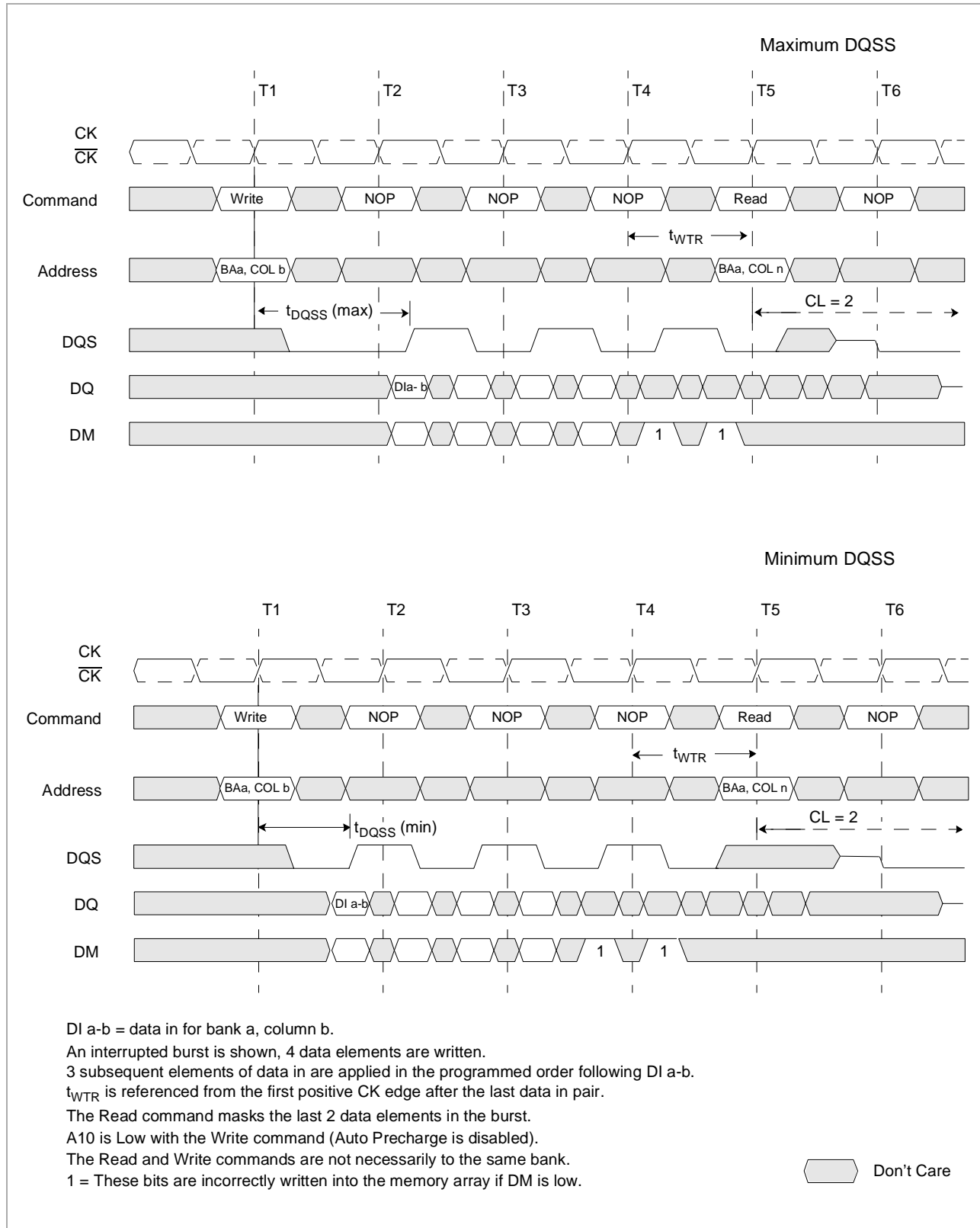

Write to Read: Minimum DQSS, Odd Number of Data (3 bit Write), Interrupting (CAS Latency = 2; Burst Length = 8)

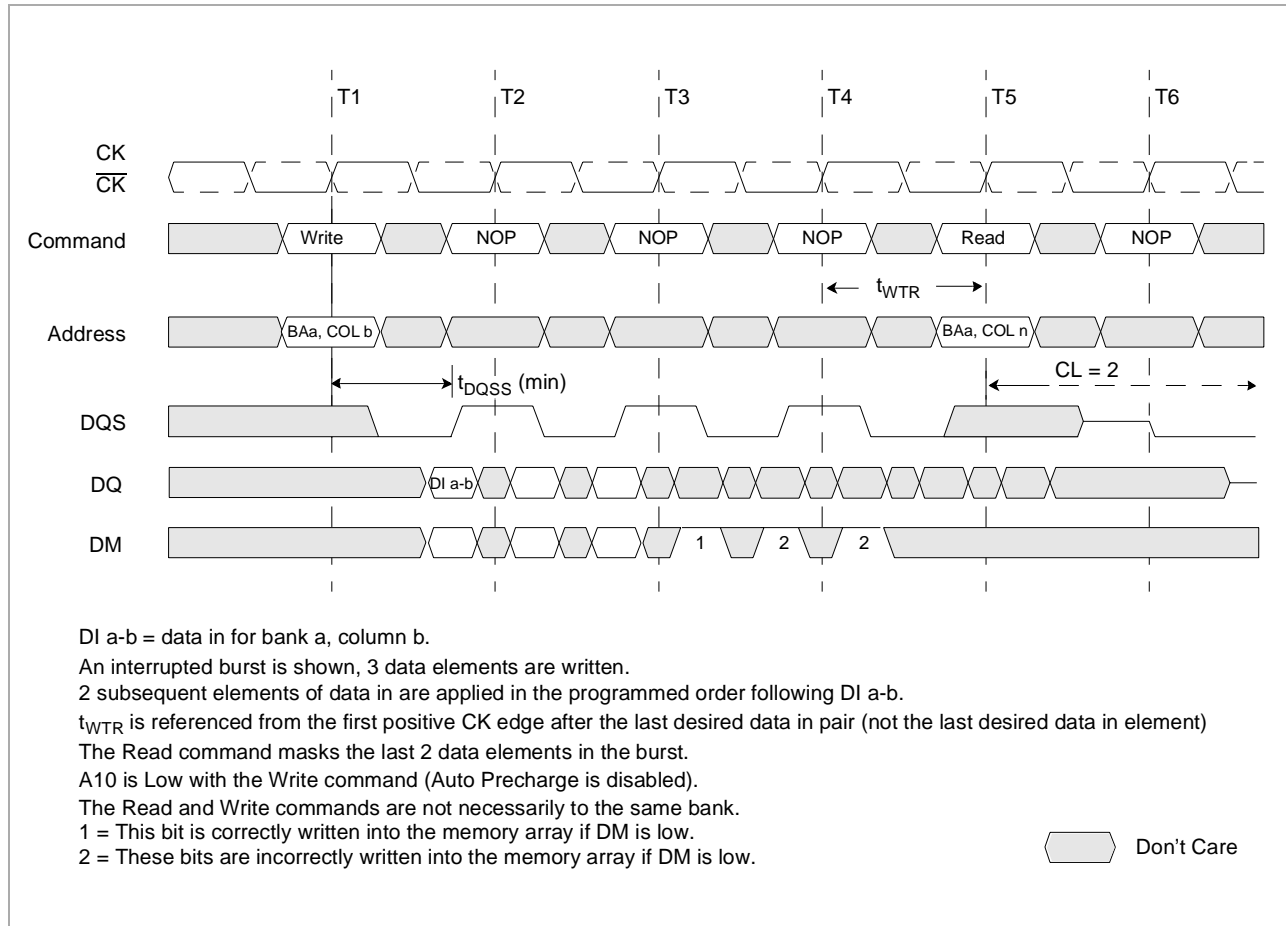

Write to Read: Nominal DQSS, Interrupting (CAS Latency = 2; Burst Length = 8)

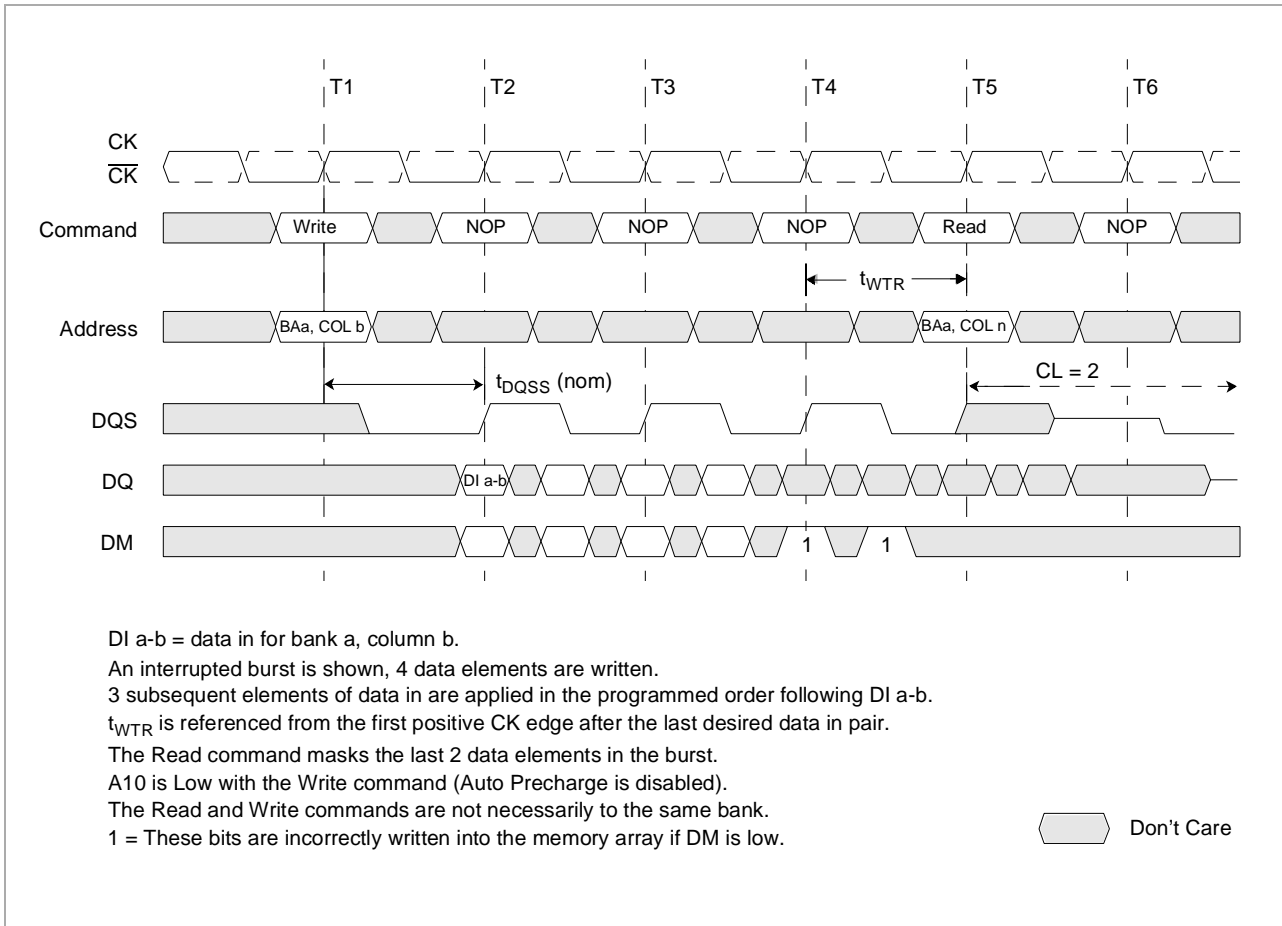

Write to Precharge: Non-Interrupting (Burst Length = 4)

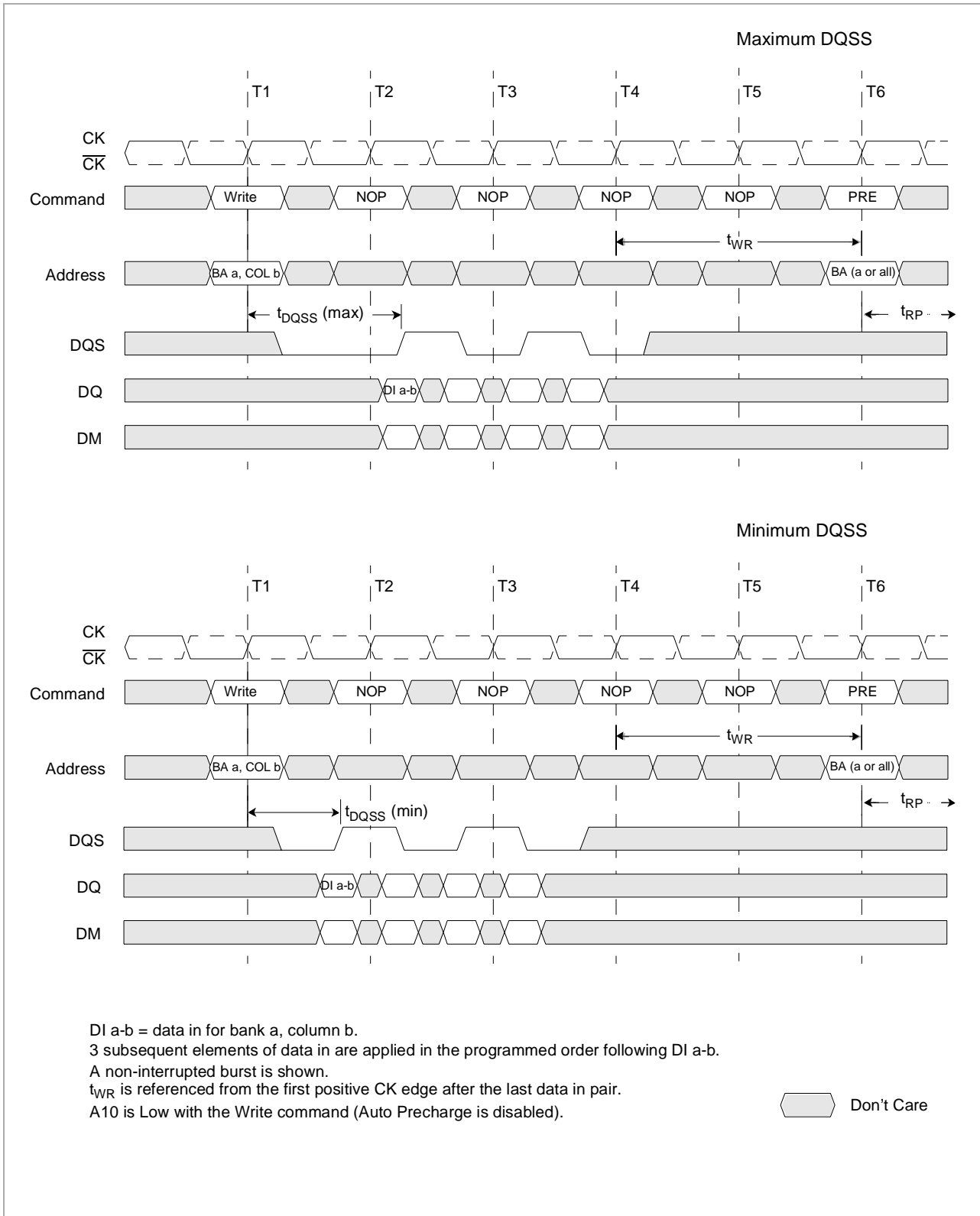

Write to Precharge: Interrupting (Burst Length = 4 or 8)

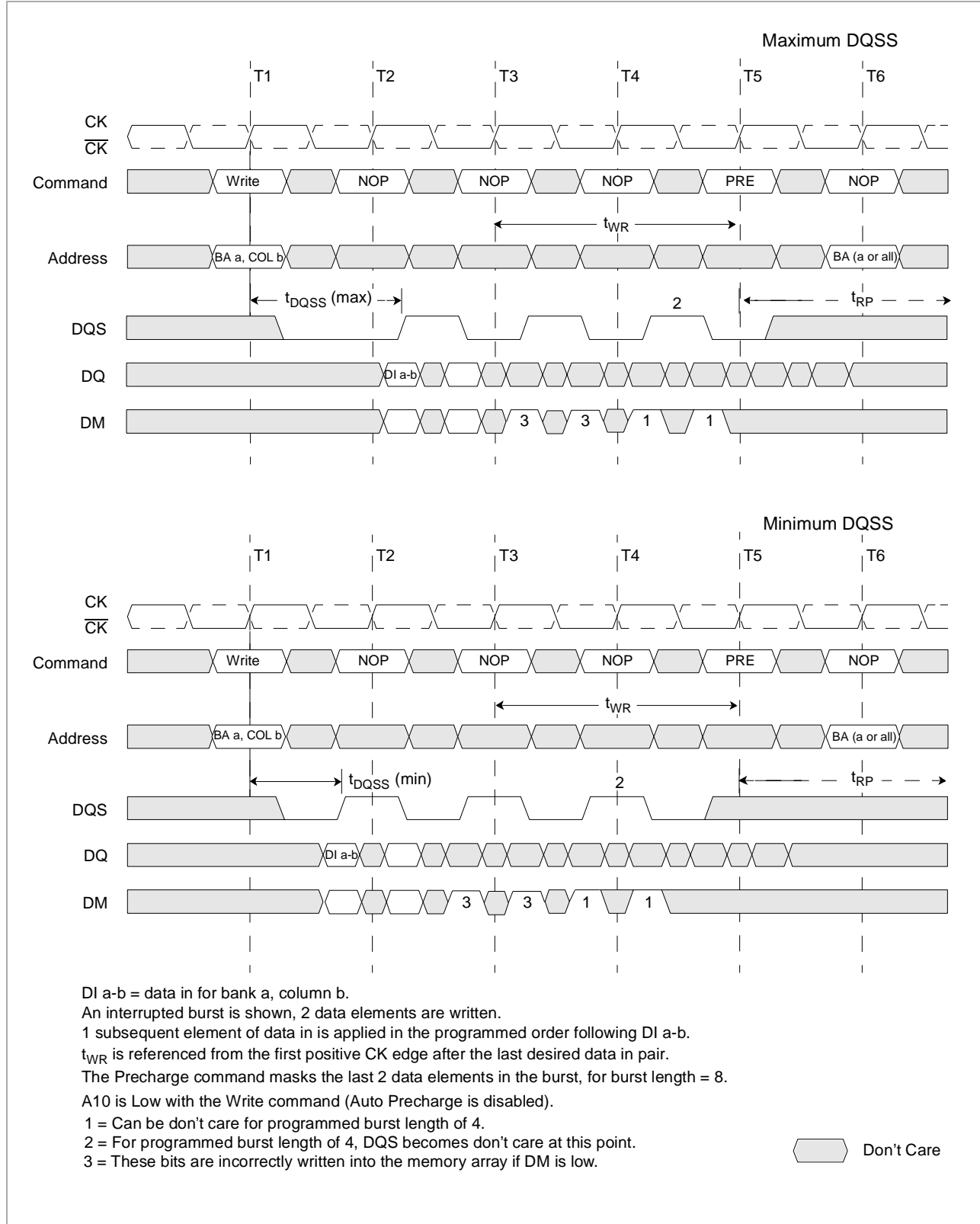

Write to Precharge: Minimum DQSS, Odd Number of Data (1 bit Write), Interrupting (Burst Length = 4 or 8)

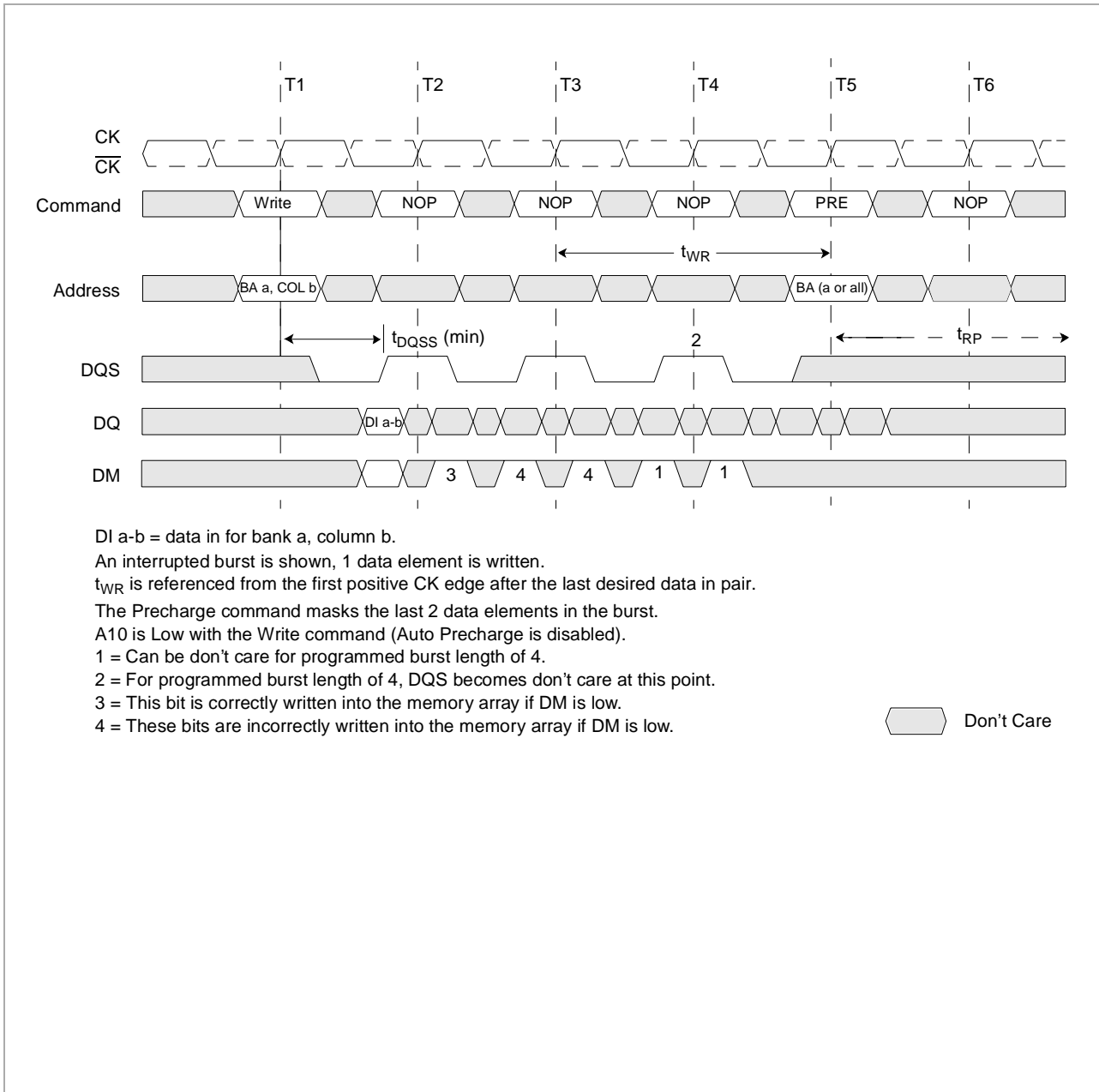

Write to Precharge: Nominal DQSS (2 bit Write), Interrupting (Burst Length = 4 or 8)

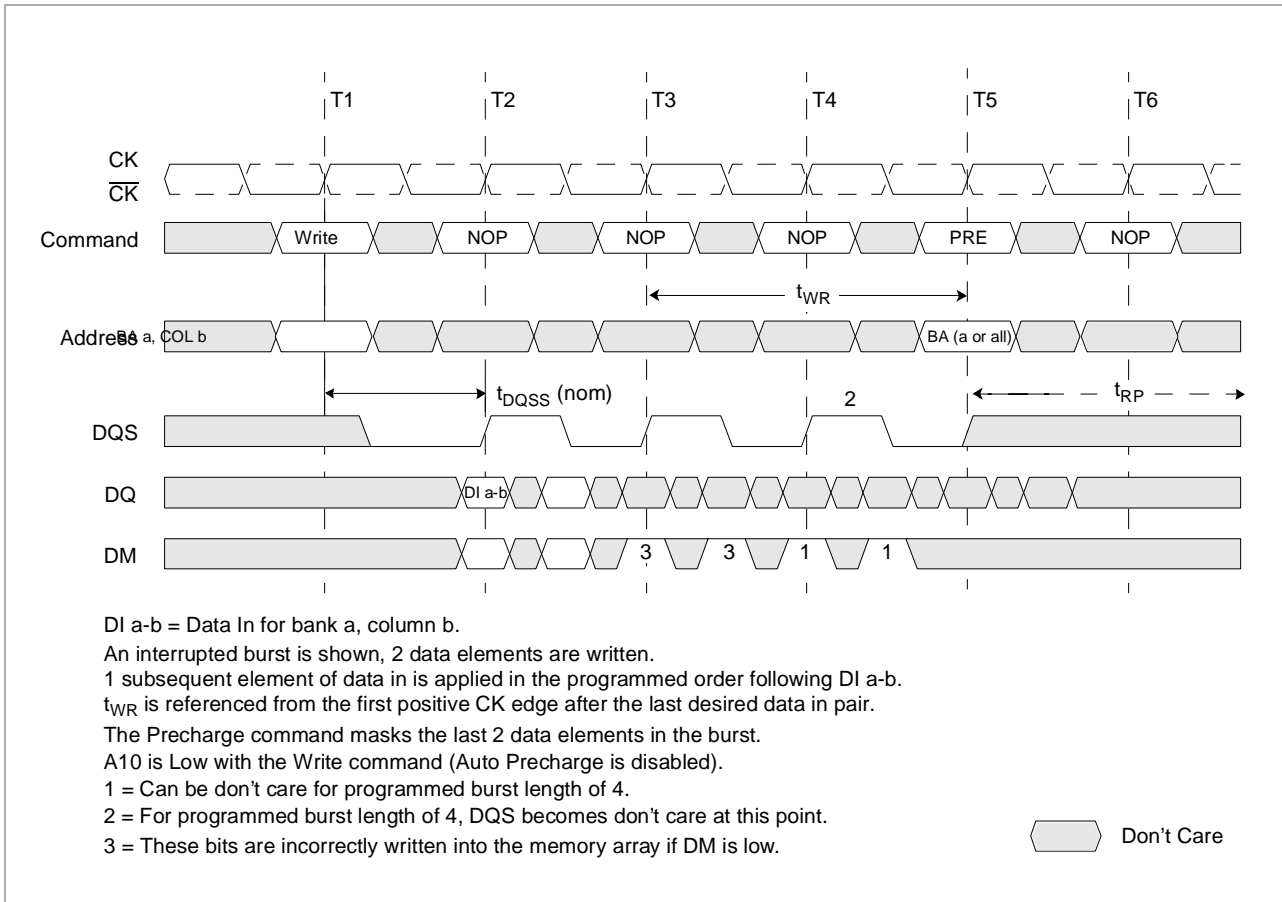

Precharge Command

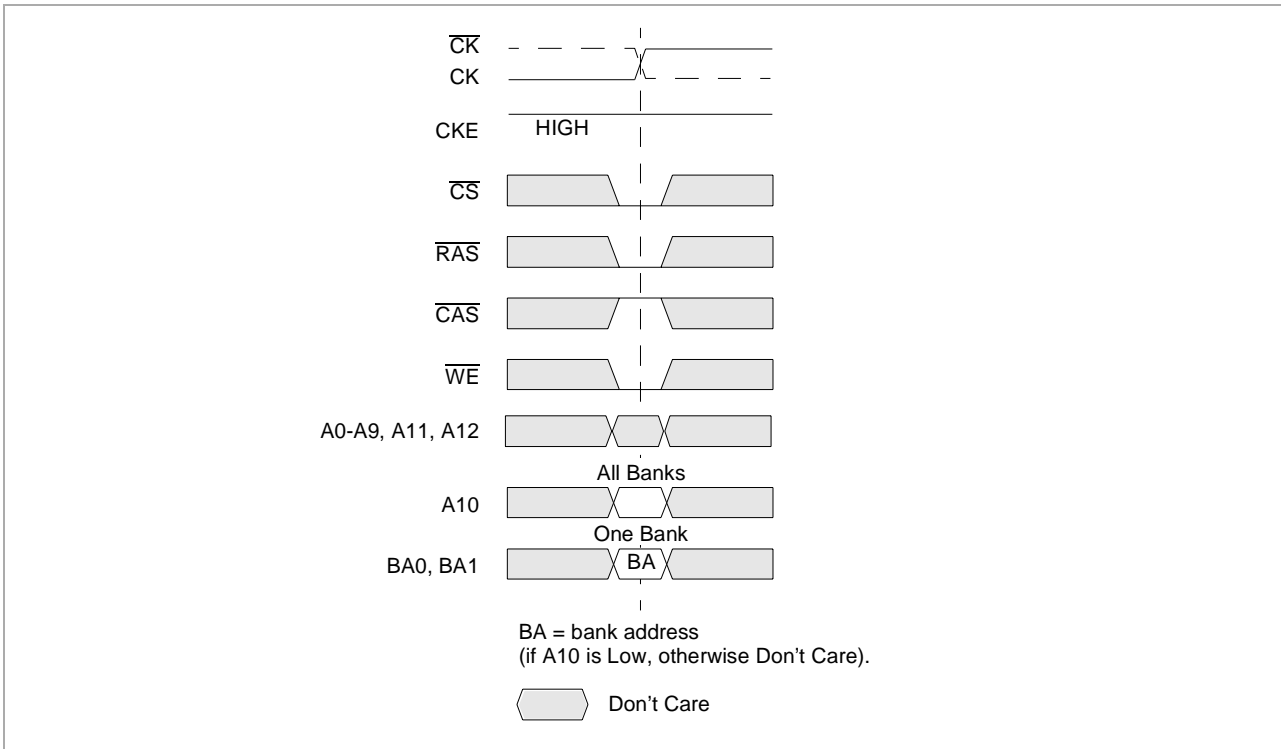

Precharge

The Precharge command is used to deactivate the open row in a particular bank or the open row in all banks. The bank(s) will be available for a subsequent row access some specified time (t_{RP}) after the Precharge command is issued. Input A10 determines whether one or all banks are to be precharged, and in the case where only one bank is to be precharged, inputs BA0, BA1 select the bank. When all banks are to be precharged, inputs BA0, BA1 are treated as "Don't Care." Once a bank has been precharged, it is in the idle state and must be activated prior to any Read or Write commands being issued to that bank.

Power-Down

Power-down is entered when CKE is registered LOW (no accesses can be in progress). If power-down occurs when all banks are idle, this mode is referred to as precharge power-down; if power-down occurs when there is a row active in any bank, this mode is referred to as active power-down. Entering power-down deactivates the input and output buffers, excluding CK, \overline{CK} and CKE. The DLL is still running in Power Down mode, so for maximum power savings, the user has the option of disabling the DLL prior to entering Power-down. In that case, the DLL must be enabled after exiting power-down, and 200 clock cycles must occur before a Read command can be issued. In power-down mode, CKE Low and a stable clock signal must be maintained at the inputs of the DDR SDRAM, and all other input signals are "Don't Care". However, power-down duration is limited by the refresh requirements of the device, so in most applications, the self refresh mode is preferred over the DLL-disabled power-down mode.

The power-down state is synchronously exited when CKE is registered HIGH (along with a Nop or Deselect command). A valid, executable command may be applied one clock cycle later.

Power Down

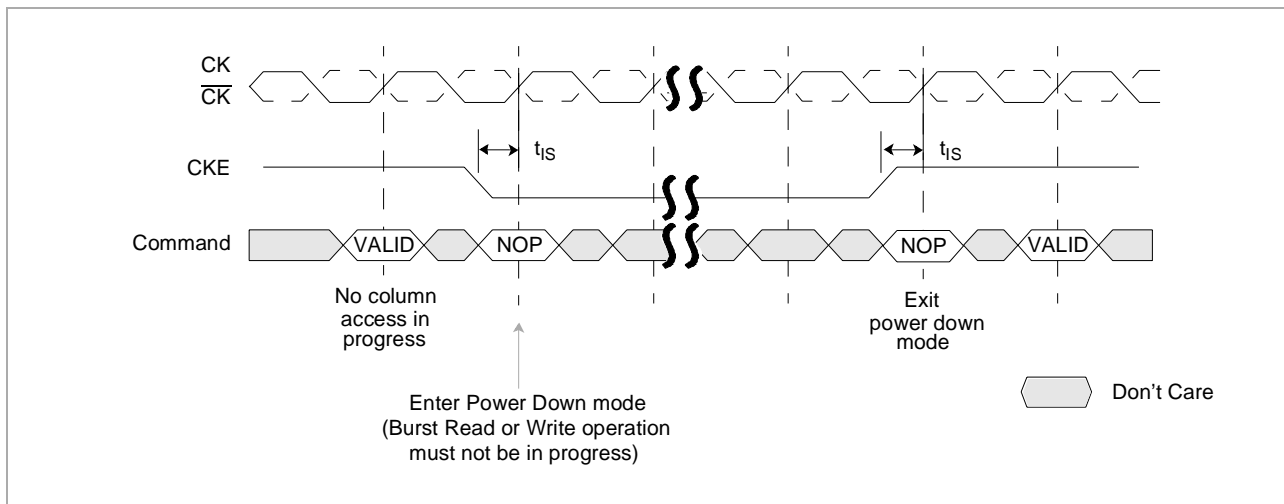

Truth Table 2: Clock Enable (CKE)

1. CKEn is the logic state of CKE at clock edge n: CKE n-1 was the state of CKE at the previous clock edge.
2. Current state is the state of the DDR SDRAM immediately prior to clock edge n.
3. COMMAND n is the command registered at clock edge n, and ACTION n is a result of COMMAND n.
4. All states and sequences not shown are illegal or reserved.

Current State	CKE n-1	CKEn	Command n	Action n	Notes
	Previous Cycle	Current Cycle			
Self Refresh	L	L	X	Maintain Self-Refresh	
Self Refresh	L	H	Deselect or NOP	Exit Self-Refresh	1
Power Down	L	L	X	Maintain Power-Down	
Power Down	L	H	Deselect or NOP	Exit Power-Down	
All Banks Idle	H	L	Deselect or NOP	Precharge Power-Down Entry	
All Banks Idle	H	L	AUTO REFRESH	Self Refresh Entry	
Bank(s) Active	H	L	Deselect or NOP	Active Power-Down Entry	
	H	H	See "Truth Table 3: Current State Bank n - Command to Bank n (Same Bank)" on page 45		

1. Deselect or NOP commands should be issued on any clock edges occurring during the Self Refresh Exit (t_{XSNR}) period. A minimum of 200 clock cycles are needed before applying a read command to allow the DLL to lock to the input clock.

Truth Table 3: Current State Bank n - Command to Bank n (Same Bank) (Part 1 of 2)

Current State	\overline{CS}	\overline{RAS}	\overline{CAS}	\overline{WE}	Command	Action	Notes
Any	H	X	X	X	Deselect	NOP. Continue previous operation	1-6
	L	H	H	H	No Operation	NOP. Continue previous operation	1-6
Idle	L	L	H	H	Active	Select and activate row	1-6
	L	L	L	H	AUTO REFRESH		1-7
	L	L	L	L	MODE REGISTER SET		1-7
Row Active	L	H	L	H	Read	Select column and start Read burst	1-6, 10
	L	H	L	L	Write	Select column and start Write burst	1-6, 10
	L	L	H	L	Precharge	Deactivate row in bank(s)	1-6, 8
Read (Auto Precharge Disabled)	L	H	L	H	Read	Select column and start new Read burst	1-6, 10
	L	L	H	L	Precharge	Truncate Read burst, start Precharge	1-6, 8
	L	H	H	L	BURST TERMINATE	BURST TERMINATE	1-6, 9

- This table applies when CKE n-1 was HIGH and CKE n is HIGH (see Truth Table 2: Clock Enable (CKE) and after t_{XSNR} / t_{XSRD} has been met (if the previous state was self refresh).
- This table is bank-specific, except where noted, i.e., the current state is for a specific bank and the commands shown are those allowed to be issued to that bank when in that state. Exceptions are covered in the notes below.
- Current state definitions:
 - Idle: The bank has been precharged, and t_{RP} has been met.
 - Row Active: A row in the bank has been activated, and t_{RCD} has been met. No data bursts/accesses and no register accesses are in progress.
 - Read: A Read burst has been initiated, with Auto Precharge disabled, and has not yet terminated or been terminated.
 - Write: A Write burst has been initiated, with Auto Precharge disabled, and has not yet terminated or been terminated.
- The following states must not be interrupted by a command issued to the same bank.
 - Precharging: Starts with registration of a Precharge command and ends when t_{RP} is met. Once t_{RP} is met, the bank is in the idle state.
 - Row Activating: Starts with registration of an Active command and ends when t_{RCD} is met. Once t_{RCD} is met, the bank is in the "row active" state.
 - Read w/Auto Precharge Enabled: Starts with registration of a Read command with Auto Precharge enabled and ends when t_{RP} has been met. Once t_{RP} is met, the bank is in the idle state.
 - Write w/Auto Precharge Enabled: Starts with registration of a Write command with Auto Precharge enabled and ends when t_{RP} has been met. Once t_{RP} is met, the bank is in the idle state.
- The following states must not be interrupted by any executable command; Deselect or NOP commands must be applied on each positive clock edge during these states.
 - Refreshing: Starts with registration of an Auto Refresh command and ends when t_{RFC} is met. Once t_{RFC} is met, the DDR SDRAM is in the "all banks idle" state.
 - Accessing Mode Register: Starts with registration of a Mode Register Set command and ends when t_{MRD} has been met. Once t_{MRD} is met, the DDR SDRAM is in the "all banks idle" state.
 - Precharging All: Starts with registration of a Precharge All command and ends when t_{RP} is met. Once t_{RP} is met, all banks is in the idle state.
- All states and sequences not shown are illegal or reserved.
- Not bank-specific; requires that all banks are idle.
- May or may not be bank-specific; if all/any banks are to be precharged, all/any must be in a valid state for precharging.
- Not bank-specific; BURST TERMINATE affects the most recent Read burst, regardless of bank.
- Reads or Writes listed in the Command/Action column include Reads or Writes with Auto Precharge enabled and Reads or Writes with Auto Precharge disabled.
- Requires appropriate DM masking.

Truth Table 3: Current State Bank n - Command to Bank n (Same Bank) (Part 2 of 2)

Current State	\overline{CS}	\overline{RAS}	\overline{CAS}	\overline{WE}	Command	Action	Notes
Write (Auto Precharge Disabled)	L	H	L	H	Read	Select column and start Read burst	1-6, 10, 11
	L	H	L	L	Write	Select column and start Write burst	1-6, 10
	L	L	H	L	Precharge	Truncate Write burst, start Precharge	1-6, 8, 11

1. This table applies when CKE n-1 was HIGH and CKE n is HIGH (see Truth Table 2: Clock Enable (CKE) and after t_{XSNR} / t_{XSRD} has been met (if the previous state was self refresh).
2. This table is bank-specific, except where noted, i.e., the current state is for a specific bank and the commands shown are those allowed to be issued to that bank when in that state. Exceptions are covered in the notes below.
3. Current state definitions:
 - Idle: The bank has been precharged, and t_{RP} has been met.
 - Row Active: A row in the bank has been activated, and t_{RCD} has been met. No data bursts/accesses and no register accesses are in progress.
 - Read: A Read burst has been initiated, with Auto Precharge disabled, and has not yet terminated or been terminated.
 - Write: A Write burst has been initiated, with Auto Precharge disabled, and has not yet terminated or been terminated.
4. The following states must not be interrupted by a command issued to the same bank.
 - Precharging: Starts with registration of a Precharge command and ends when t_{RP} is met. Once t_{RP} is met, the bank is in the idle state.
 - Row Activating: Starts with registration of an Active command and ends when t_{RCD} is met. Once t_{RCD} is met, the bank is in the "row active" state.
 - Read w/Auto Precharge Enabled: Starts with registration of a Read command with Auto Precharge enabled and ends when t_{RP} has been met. Once t_{RP} is met, the bank is in the idle state.
 - Write w/Auto Precharge Enabled: Starts with registration of a Write command with Auto Precharge enabled and ends when t_{RP} has been met. Once t_{RP} is met, the bank is in the idle state.
5. The following states must not be interrupted by any executable command; Deselect or NOP commands must be applied on each positive clock edge during these states.
 - Refreshing: Starts with registration of an Auto Refresh command and ends when t_{RFC} is met. Once t_{RFC} is met, the DDR SDRAM is in the "all banks idle" state.
 - Accessing Mode Register: Starts with registration of a Mode Register Set command and ends when t_{MRD} has been met. Once t_{MRD} is met, the DDR SDRAM is in the "all banks idle" state.
 - Precharging All: Starts with registration of a Precharge All command and ends when t_{RP} is met. Once t_{RP} is met, all banks is in the idle state.
6. All states and sequences not shown are illegal or reserved.
7. Not bank-specific; requires that all banks are idle.
8. May or may not be bank-specific; if all/any banks are to be precharged, all/any must be in a valid state for precharging.
9. Not bank-specific; BURST TERMINATE affects the most recent Read burst, regardless of bank.
10. Reads or Writes listed in the Command/Action column include Reads or Writes with Auto Precharge enabled and Reads or Writes with Auto Precharge disabled.
11. Requires appropriate DM masking.

Truth Table 4: Current State Bank n - Command to Bank m (Different bank)
(Part 1 of 2)

Current State	\overline{CS}	\overline{RAS}	\overline{CAS}	\overline{WE}	Command	Action	Notes
Any	H	X	X	X	Deselect	NOP/continue previous operation	1-6
	L	H	H	H	No Operation	NOP/continue previous operation	1-6
Idle	X	X	X	X	Any Command Otherwise Allowed to Bank m		1-6
Row Activating, Active, or Precharging	L	L	H	H	Active	Select and activate row	1-6
	L	H	L	H	Read	Select column and start Read burst	1-7
	L	H	L	L	Write	Select column and start Write burst	1-7
	L	L	H	L	Precharge		1-6
Read (Auto Precharge Disabled)	L	L	H	H	Active	Select and activate row	1-6
	L	H	L	H	Read	Select column and start new Read burst	1-7
	L	L	H	L	Precharge		1-6
Write (Auto Precharge Disabled)	L	L	H	H	Active	Select and activate row	1-6
	L	H	L	H	Read	Select column and start Read burst	1-8
	L	H	L	L	Write	Select column and start new Write burst	1-7
	L	L	H	L	Precharge		1-6
Read (With Auto Precharge)	L	L	H	H	Active	Select and activate row	1-6
	L	H	L	H	Read	Select column and start new Read burst	1-7,10
	L	H	L	L	Write	Select column and start Write burst	1-7,9,10
	L	L	H	L	Precharge		1-6

- This table applies when CKE n-1 was HIGH and CKE n is HIGH (see Truth Table 2: Clock Enable (CKE) and after t_{XSNR} / t_{XSRD} has been met (if the previous state was self refresh).
- This table describes alternate bank operation, except where noted, i.e., the current state is for bank n and the commands shown are those allowed to be issued to bank m (assuming that bank m is in such a state that the given command is allowable). Exceptions are covered in the notes below.
- Current state definitions:
 Idle: The bank has been precharged, and t_{RP} has been met.
 Row Active: A row in the bank has been activated, and t_{RCD} has been met. No data bursts/accesses and no register accesses are in progress.
 Read: A Read burst has been initiated, with Auto Precharge disabled, and has not yet terminated or been terminated.
 Write: A Write burst has been initiated, with Auto Precharge disabled, and has not yet terminated or been terminated.
 Read with Auto Precharge Enabled: See note 10.
 Write with Auto Precharge Enabled: See note 10.
- AUTO REFRESH and Mode Register Set commands may only be issued when all banks are idle.
- A BURST TERMINATE command cannot be issued to another bank; it applies to the bank represented by the current state only.
- All states and sequences not shown are illegal or reserved.
- Reads or Writes listed in the Command/Action column include Reads or Writes with Auto Precharge enabled and Reads or Writes with Auto Precharge disabled.
- Requires appropriate DM masking.
- A Write command may be applied after the completion of data output.
- Concurrent Auto Precharge:**
 This device supports "Concurrent Auto Precharge". When a read with auto precharge or a write with auto precharge is enabled any command may follow to the other banks as long as that command does not interrupt the read or write data transfer and all other limitations apply (e.g. contention between READ data and WRITE data must be avoided). The minimum delay from a read or write command with auto precharge enable, to a command to a different banks is summarized in table 4a.

Truth Table 4: Current State Bank n - Command to Bank m (Different bank)
(Part 2 of 2)

Current State	\overline{CS}	\overline{RAS}	\overline{CAS}	\overline{WE}	Command	Action	Notes
Write (With Auto Precharge)	L	L	H	H	Active	Select and activate row	1-6
	L	H	L	H	Read	Select column and start Read burst	1-7,10
	L	H	L	L	Write	Select column and start new Write burst	1-7,10
	L	L	H	L	Precharge		1-6

- This table applies when CKE n-1 was HIGH and CKE n is HIGH (see Truth Table 2: Clock Enable (CKE) and after t_{XSNR} / t_{XSRD} has been met (if the previous state was self refresh).
- This table describes alternate bank operation, except where noted, i.e., the current state is for bank n and the commands shown are those allowed to be issued to bank m (assuming that bank m is in such a state that the given command is allowable). Exceptions are covered in the notes below.
- Current state definitions:
 - Idle: The bank has been precharged, and t_{RP} has been met.
 - Row Active: A row in the bank has been activated, and t_{RCD} has been met. No data bursts/accesses and no register accesses are in progress.
 - Read: A Read burst has been initiated, with Auto Precharge disabled, and has not yet terminated or been terminated.
 - Write: A Write burst has been initiated, with Auto Precharge disabled, and has not yet terminated or been terminated.
 - Read with Auto Precharge Enabled: See note 10.
 - Write with Auto Precharge Enabled: See note 10.
- AUTO REFRESH and Mode Register Set commands may only be issued when all banks are idle.
- A BURST TERMINATE command cannot be issued to another bank; it applies to the bank represented by the current state only.
- All states and sequences not shown are illegal or reserved.
- Reads or Writes listed in the Command/Action column include Reads or Writes with Auto Precharge enabled and Reads or Writes with Auto Precharge disabled.
- Requires appropriate DM masking.
- A Write command may be applied after the completion of data output.
- Concurrent Auto Precharge:**
This device supports "Concurrent Auto Precharge". When a read with auto precharge or a write with auto precharge is enabled any command may follow to the other banks as long as that command does not interrupt the read or write data transfer and all other limitations apply (e.g. contention between READ data and WRITE data must be avoided). The minimum delay from a read or write command with auto precharge enable, to a command to a different banks is summarized in table 4a.

Truth Table 4a : Concurrent Auto Precharge:

From Command	To Command (different bank)	Minimum Delay with Concurrent Auto Precharge Support	Units
WRITE w/AP	Read or Read w/AP	$1 + (BL/2) + t_{WTR}$	tCK
	Write or Write w/AP	BL/2	tCK
	Precharge or Activate	1	tCK
Read w/AP	Read or Read w/AP	BL/2	tCK
	Write or Write w/AP	CL (rounded up)+ BL/2	tCK
	Precharge or Activate	1	tCK

Absolute Maximum Ratings

Symbol	Parameter	Rating	Units
V_{IN}, V_{OUT}	Voltage on I/O pins relative to V_{SS}	-0.5 to $V_{DDQ} + 0.5$	V
V_{IN}	Voltage on Inputs relative to V_{SS}	-0.5 to $+3.6$	V
V_{DD}	Voltage on V_{DD} supply relative to V_{SS}	-0.5 to $+3.6$	V
V_{DDQ}	Voltage on V_{DDQ} supply relative to V_{SS}	-0.5 to $+3.6$	V
T_A	Operating Temperature (Ambient)	0 to $+70$	$^{\circ}\text{C}$
T_{STG}	Storage Temperature (Plastic)	-55 to $+150$	$^{\circ}\text{C}$
P_D	Power Dissipation	1.0	W
I_{OUT}	Short Circuit Output Current	50	mA

Note: Stresses greater than those listed under “Absolute Maximum Ratings” may cause permanent damage to the device. This is a stress rating only, and functional operation of the device at these or any other conditions above those indicated in the operational sections of this specification is not implied. Exposure to absolute maximum rating conditions for extended periods may affect reliability.

Capacitance

Parameter	Symbol	Min.	Max.	Units	Notes
Input Capacitance: CK, $\overline{\text{CK}}$	C_{I1}	2.0	3.0	pF	1, 3
Input Capacitance: All other input-only pins (except DM)	C_{I2}	2.0	3.0	pF	1, 3
Input/Output Capacitance: DQ, DQS, DM	C_{IO}	4.0	5.0	pF	1, 2, 3
Output Capacitance: $\overline{\text{QFC}}$	CO_1	2.0	4.0	pF	1, 3
Delta Input capacitance for DQ, DQS, DM	ΔC	-	0.5	pF	3
Delta Input capacitance for CK, $\overline{\text{CK}}$	ΔC	-	0.25	pF	3

1. $V_{DDQ} = V_{DD} = 2.5V \pm 0.2V$, $f = 100\text{MHz}$, $T_A = 25^\circ\text{C}$, $V_{OUT}(\text{DC}) = V_{DDQ}/2$, $V_{OUT}(\text{Peak to Peak}) = 0.2V$.
2. DM inputs are grouped with I/O pins reflecting the fact that they are matched in loading to DQ and DQS to facilitate trace matching at the board level.
3. All capacitances are guaranteed by design and are tested on a samples basis only.

Electrical Characteristics and DC Operating Conditions

($0^\circ\text{C} \leq T_A \leq 70^\circ\text{C}$; $V_{DDQ} = 2.5V \pm 0.2V$, $V_{DD} = +2.5V \pm 0.2V$, see AC Characteristics)

Symbol	Parameter	Min	Max	Units	Notes
V_{DD}	Supply Voltage	2.3	2.7	V	1
V_{DDQ}	I/O Supply Voltage	2.3	2.7	V	1
V_{SS} , V_{SSQ}	Supply Voltage, I/O Supply Voltage	0	0	V	
V_{REF}	I/O Reference Voltage	$0.49 \times V_{DDQ}$	$0.51 \times V_{DDQ}$	V	1, 2
V_{TT}	I/O Termination Voltage (System)	$V_{REF} - 0.04$	$V_{REF} + 0.04$	V	1, 3
$V_{IH(\text{DC})}$	Input High (Logic1) Voltage	$V_{REF} + 0.15$	$V_{DDQ} + 0.3$	V	1
$V_{IL(\text{DC})}$	Input Low (Logic0) Voltage	-0.3	$V_{REF} - 0.15$	V	1
$V_{IN(\text{DC})}$	Input Voltage Level, CK and $\overline{\text{CK}}$ Inputs	-0.3	$V_{DDQ} + 0.3$	V	1
$V_{ID(\text{DC})}$	Input Differential Voltage, CK and $\overline{\text{CK}}$ Inputs	0.3	$V_{DDQ} + 0.6$	V	1, 4
$V_{I\text{Ratio}}$	VI-Matching Pullup Current to Pulldown Current	0.71	1.4		5
I_I	Input Leakage Current Any input $0V \leq V_{IN} \leq V_{DD}$ (All other pins not under test = 0V)	-2	2	μA	1
I_{OZ}	Output Leakage Current (DQs are disabled; $0V \leq V_{out} \leq V_{DDQ}$)	-5	5	μA	1
I_{OH}	Output High Current, Normal Strength Driver ($V_{OUT} = V_{DDQ} - 0.373V$, min V_{REF} , min V_{TT})	-16.8		mA	1
I_{OL}	Output Low Current, Normal Strength Driver ($V_{OUT} = 0.373V$, max V_{REF} , max. V_{TT})	16.8		mA	1

- Inputs are not recognized as valid until V_{REF} stabilizes.
- V_{REF} is expected to be equal to $0.5 V_{DDQ}$ of the transmitting device, and to track variations in the DC level of the same. Peak-to-peak noise on V_{REF} may not exceed $\pm 2\%$ of the DC value.
- V_{TT} is not applied directly to the device. V_{TT} is a system supply for signal termination resistors, is expected to be set equal to V_{REF} and must track variations in the DC level of V_{REF} .
- V_{ID} is the magnitude of the difference between the input level on CK and the input level on $\overline{\text{CK}}$.
- The ration of the pullup current to the pulldown current is specified for the same temperature and voltage, over the entire temperature and voltage range, for device drain to source voltage from 0.25 to 1.0V. For a given output, it represents the maximum difference between pullup and pulldown drivers due to process variation.

Pulldown and Pullup Characteristics

1. The nominal pulldown V-I curve for DDR SDRAM devices is expected, but not guaranteed, to lie within the inner bounding lines of the V-I curve.
2. The full variation in driver pulldown current from minimum to maximum process, temperature, and voltage lie within the outer bounding lines of the V-I curve.

Pulldown Characteristics

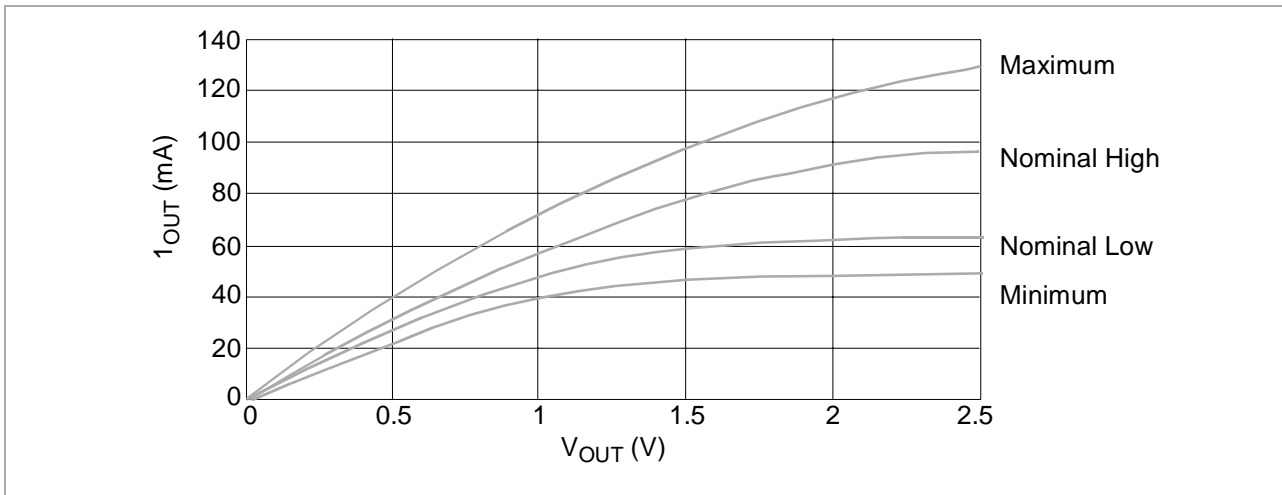

3. The nominal pullup V-I curve for DDR SDRAM devices is expected, but not guaranteed, to lie within the inner bounding lines of the V-I curve.
4. The full variation in driver pullup current from minimum to maximum process, temperature, and voltage lie within the outer bounding lines of the V-I curve.

Pullup Characteristics

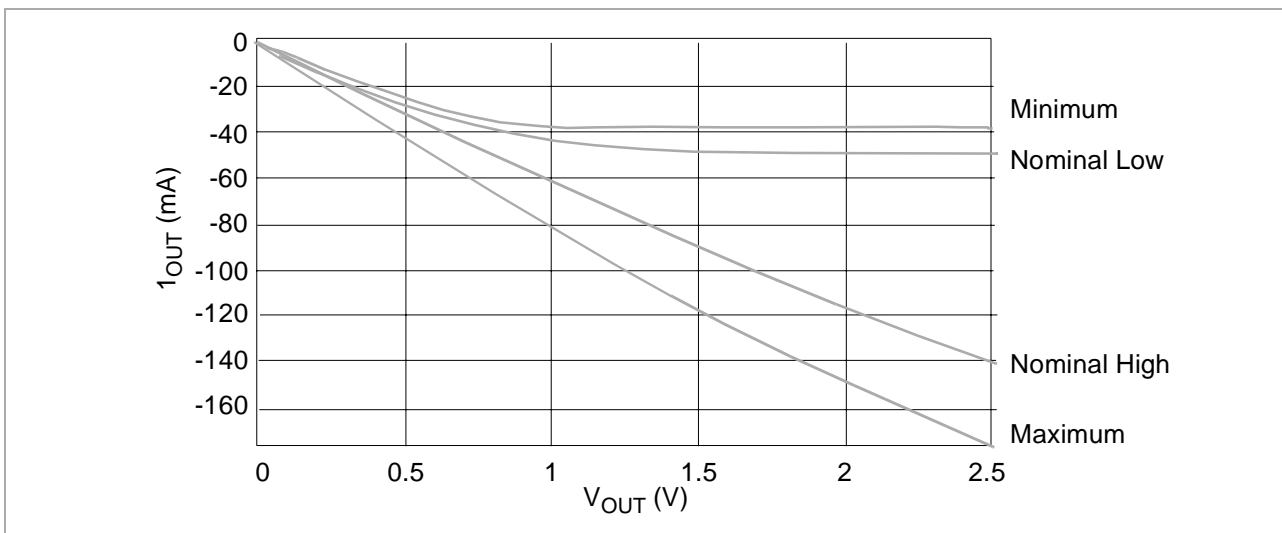

5. The full variation in the ratio of the maximum to minimum pullup and pulldown current does not exceed 1.7, for device drain to source voltages from 0.1 to 1.0.
6. The full variation in the ratio of the nominal pullup to pulldown current should be unity $\pm 10\%$, for device drain to source voltages from 0.1 to 1.0V.

Pulldown and Pullup Currents

Voltage (V)	Pulldown Current (mA)				Pullup Current (mA)			
	Nominal Low	Nominal High	Min	Max	Nominal Low	Nominal High	Min	Max
0.1	6.0	6.8	4.6	9.6	-6.1	-7.6	-4.6	-10.0
0.2	12.2	13.5	9.2	18.2	-12.2	-14.5	-9.2	-20.0
0.3	18.1	20.1	13.8	26.0	-18.1	-21.2	-13.8	-29.8
0.4	24.1	26.6	18.4	33.9	-24.0	-27.7	-18.4	-38.8
0.5	29.8	33.0	23.0	41.8	-29.8	-34.1	-23.0	-46.8
0.6	34.6	39.1	27.7	49.4	-34.3	-40.5	-27.7	-54.4
0.7	39.4	44.2	32.2	56.8	-38.1	-46.9	-32.2	-61.8
0.8	43.7	49.8	36.8	63.2	-41.1	-53.1	-36.0	-69.5
0.9	47.5	55.2	39.6	69.9	-43.8	-59.4	-38.2	-77.3
1.0	51.3	60.3	42.6	76.3	-46.0	-65.5	-38.7	-85.2
1.1	54.1	65.2	44.8	82.5	-47.8	-71.6	-39.0	-93.0
1.2	56.2	69.9	46.2	88.3	-49.2	-77.6	-39.2	-100.6
1.3	57.9	74.2	47.1	93.8	-50.0	-83.6	-39.4	-108.1
1.4	59.3	78.4	47.4	99.1	-50.5	-89.7	-39.6	-115.5
1.5	60.1	82.3	47.7	103.8	-50.7	-95.5	-39.9	-123.0
1.6	60.5	85.9	48.0	108.4	-51.0	-101.3	-40.1	-130.4
1.7	61.0	89.1	48.4	112.1	-51.1	-107.1	-40.2	-136.7
1.8	61.5	92.2	48.9	115.9	-51.3	-112.4	-40.3	-144.2
1.9	62.0	95.3	49.1	119.6	-51.5	-118.7	-40.4	-150.5
2.0	62.5	97.2	49.4	123.3	-51.6	-124.0	-40.5	-156.9
2.1	62.9	99.1	49.6	126.5	-51.8	-129.3	-40.6	-163.2
2.2	63.3	100.9	49.8	129.5	-52.0	-134.6	-40.7	-169.6
2.3	63.8	101.9	49.9	132.4	-52.2	-139.9	-40.8	-176.0
2.4	64.1	102.8	50.0	135.0	-52.3	-145.2	-40.9	-181.3
2.5	64.6	103.8	50.2	137.3	-52.5	-150.5	-41.0	-187.6
2.6	64.8	104.6	50.4	139.2	-52.7	-155.3	-41.1	-192.9
2.7	65.0	105.4	50.5	140.8	-52.8	-160.1	-41.2	-198.2

Pulldown and Pullup Process Variations and Conditions

	Nominal	Minimum	Maximum
Operating Temperature	25 °C	0 °C	70 °C
V_{DD}/V_{DDQ}	2.5V	2.3V	2.7V

The above characteristics are specified under best, worst, and nominal process variations / conditions.

AC Characteristics

(Notes 1-5 apply to the following Tables; Electrical Characteristics and DC Operating Conditions, AC Operating Conditions, I_{DD} Specifications and Conditions, and Electrical Characteristics and AC Timing.)

1. All voltages referenced to V_{SS} .
2. Tests for AC timing, I_{DD} , and electrical, AC and DC characteristics, may be conducted at nominal reference/supply voltage levels, but the related specifications and device operation are guaranteed for the full voltage range specified.
3. The figure below represents the timing reference load used in defining the relevant timing parameters of the part. It is not intended to be either a precise representation of the typical system environment nor a depiction of the actual load presented by a production tester. System designers will use IBIS or other simulation tools to correlate the timing reference load to a system environment. Manufacturers will correlate to their production test conditions (generally a coaxial transmission line terminated at the tester electronics).
4. AC timing and I_{DD} tests may use a V_{IL} to V_{IH} swing of up to 1.5V in the test environment, but input timing is still referenced to V_{REF} (or to the crossing point for CK , \overline{CK}), and parameter specifications are guaranteed for the specified AC input levels under normal use conditions. The minimum slew rate for the input signals is 1V/ns in the range between $V_{IL(AC)}$ and $V_{IH(AC)}$.
5. The AC and DC input level specifications are as defined in the SSTL_2 Standard (i.e. the receiver effectively switches as a result of the signal crossing the AC input level, and remains in that state as long as the signal does not ring back above (below) the DC input LOW (HIGH) level).
6. For DDR SDRAM AC Overshoot / Undershoot Specification see JEDEC ballot JC-42.3-00-121, jcb-00-083, Item 193B
For DQ / DM /DQS input slew rate see JEDEC ballot JC-42.3-00-177, JCB-00-085, Item 1178.09
For I/O Delta Rise / Fall Derating see JEDEC ballot JC-42.3-00-208, JCB-00-088, Item 1178.13
For general standardization of DDR SDRAM low rate see JEDEC ballot JC-42.3-00-117, JCB-00-089, Item 1091B

AC Output Load Circuit Diagram / Timing Reference Load

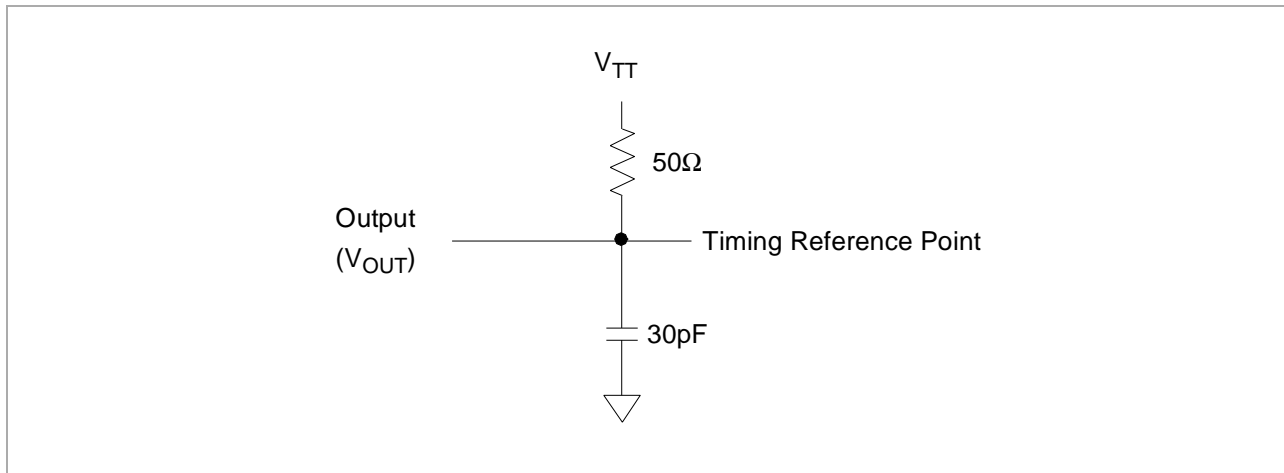

AC Operating Conditions ($0\text{ }^{\circ}\text{C} \leq T_A \leq 70\text{ }^{\circ}\text{C}$; $V_{DDQ} = 2.5\text{V} \pm 0.2\text{V}$; $V_{DD} = 2.5\text{V} \pm 0.2\text{V}$, See AC Characteristics)

Symbol	Parameter/Condition	Min	Max	Unit	Notes
$V_{IH(AC)}$	Input High (Logic 1) Voltage, DQ, DQS, and DM Signals	$V_{REF} + 0.31$		V	1, 2
$V_{IL(AC)}$	Input Low (Logic 0) Voltage, DQ, DQS, and DM Signals		$V_{REF} - 0.31$	V	1, 2
$V_{ID(AC)}$	Input Differential Voltage, CK and \overline{CK} Inputs	0.62	$V_{DDQ} + 0.6$	V	1, 2, 3
$V_{IX(AC)}$	Input Closing Point Voltage, CK and \overline{CK} Inputs	$0.5 \cdot V_{DDQ} - 0.2$	$0.5 \cdot V_{DDQ} + 0.2$	V	1, 2, 4

1. Input slew rate = 1V/ns.
2. Inputs are not recognized as valid until V_{REF} stabilizes.
3. V_{ID} is the magnitude of the difference between the input level on CK and the input level on \overline{CK} .
4. The value of V_{IX} is expected to equal $0.5 \cdot V_{DDQ}$ of the transmitting device and must track variations in the DC level of the same.

I_{DD} Specifications and Conditions ($0\text{ }^{\circ}\text{C} \leq T_A \leq 70\text{ }^{\circ}\text{C}$; $V_{DDQ} = 2.5\text{V} \pm 0.2\text{V}$; $V_{DD} = 2.5\text{V} \pm 0.2\text{V}$, See AC Characteristics)

Symbol	Parameter/Condition	DDR266	DDR200	Unit	Notes
I_{DD0}	Operating Current: one bank; active / precharge; $t_{RC} = t_{RC\text{ MIN}}$; $t_{CK} = t_{CK\text{ MIN}}$; DQ, DM, and DQS inputs changing twice per clock cycle; address and control inputs changing once per clock cycle	100	90	mA	1, 2
I_{DD1}	Operating Current: one bank; active / read / precharge; Burst = 2; $t_{RC} = t_{RC\text{ MIN}}$; CL = 2.5; $t_{CK} = t_{CK\text{ MIN}}$; $I_{OUT} = 0\text{mA}$; address and control inputs changing once per clock cycle	120	100	mA	1, 2
I_{DD2P}	Precharge Power-Down Standby Current: all banks idle; power-down mode; $CKE \leq V_{IL\text{ MAX}}$; $t_{CK} = t_{CK\text{ MIN}}$	20	15	mA	1, 2
I_{DD2N}	Idle Standby Current: $\overline{CS} \geq V_{IH\text{ MIN}}$; all banks idle; $CKE \geq V_{IH\text{ MIN}}$; $t_{CK} = t_{CK\text{ MIN}}$; address and control inputs changing once per clock cycle	40	35	mA	1, 2
I_{DD3P}	Active Power-Down Standby Current: one bank active; power-down mode; $CKE \leq V_{IL\text{ MAX}}$; $t_{CK} = t_{CK\text{ MIN}}$	20	15	mA	1, 2
I_{DD3N}	Active Standby Current: one bank; active / precharge; $\overline{CS} \geq V_{IH\text{ MIN}}$; $CKE \geq V_{IH\text{ MIN}}$; $t_{RC} = t_{RAS\text{ MAX}}$; $t_{CK} = t_{CK\text{ MIN}}$; DQ, DM, and DQS inputs changing twice per clock cycle; address and control inputs changing once per clock cycle	70	60	mA	1, 2
I_{DD4R}	Operating Current: one bank; Burst = 2; reads; continuous burst; address and control inputs changing once per clock cycle; DQ and DQS outputs changing twice per clock cycle; CL = 2.5; $t_{CK} = t_{CK\text{ MIN}}$; $I_{OUT} = 0\text{mA}$	190	150	mA	1, 2
I_{DD4W}	Operating Current: one bank; Burst = 2; writes; continuous burst; address and control inputs changing once per clock cycle; DQ and DQS inputs changing twice per clock cycle; CL = 2.5; $t_{CK} = t_{CK\text{ MIN}}$	170	130	mA	1, 2
I_{DD5}	Auto-Refresh Current: $t_{RC} = t_{RFC\text{ MIN}}$	190	180	mA	1, 2
I_{DD6}	Self-Refresh Current: $CKE \leq 0.2\text{V}$	3	3	mA	1, 2, 3
I_{DD7}	Operating Current: four bank; four bank interleaving with BL=4, address and control inputs randomly changing; 50% of data changing at every transfer; $t_{RC} = t_{RC\text{ MIN}}$; $I_{OUT} = 0\text{mA}$	325	250	mA	1

1. I_{DD} specifications are tested after the device is properly initialized and measured at 100 Mhz for DDR200 and 133 MHz for DDR266
2. Input slew rate = 1V/ns.
3. Enables on-chip refresh and address counters.

Electrical Characteristics & AC Timing for DDR266/DDR200 - Absolute Specifications

(0 °C ≤ T_A ≤ 70 °C; V_{DDQ} = 2.5V ± 0.2V; V_{DD} = 2.5V ± 0.2V, See AC Characteristics) (Part 1 of 3)

Symbol	Parameter	DDR266A -7		DDR266B -7.5		DDR200 -8		Unit	Notes	
		Min	Max	Min	Max	Min	Max			
t _{AC}	DQ output access time from CK/ \overline{CK}	- 0.75	+ 0.75	- 0.75	+ 0.75	- 0.8	+ 0.8	ns	1-4	
t _{DQSK}	DQS output access time from CK/ \overline{CK}	- 0.75	+ 0.75	- 0.75	+ 0.75	- 0.8	+ 0.8	ns	1-4	
t _{CH}	CK high-level width	0.45	0.55	0.45	0.55	0.45	0.55	t _{CK}	1-4	
t _{CL}	CK low-level width	0.45	0.55	0.45	0.55	0.45	0.55	t _{CK}	1-4	
t _{HP}	Clock Half Period	min (t _{CL} , t _{CH})		min (t _{CL} , t _{CH})		min (t _{CL} , t _{CH})		ns	1-4	
t _{CK}	Clock cycle time	CL = 2.5	7	25	7.5	12	8	12	ns	1-4
t _{CK}		CL = 2.0	7.5	12	8	12	10	12	ns	1-4
t _{DH}	DQ and DM input hold time	0.5		0.5		0.6		ns	1-4	
t _{DS}	DQ and DM input setup time	0.5		0.5		0.6		ns	1-4	
t _{IPW}	Control and Addr. input pulse width (each input)	2.2		2.2		2.5		ns	1-, 12	
t _{DIPW}	DQ and DM input pulse width (each input)	1.75		1.75		2		ns	1-4,12	
t _{HZ}	Data-out high-impedence time from CK/ \overline{CK}	- 0.75	+ 0.75	- 0.75	+ 0.75	- 0.8	+ 0.8	ns	1-4, 5	
t _{LZ}	Data-out low-impedence time from CK/ \overline{CK}	- 0.75	+ 0.75	- 0.75	+ 0.75	- 0.8	+ 0.8	ns	1-4, 5	
t _{DQSS}	Write command to 1st DQS latching transition	0.75	1.25	0.75	1.25	0.75	1.25	t _{CK}	1-4	
t _{DQSQ}	DQS-DQ skew (for DQS & associated DQ signals)		+ 0.5		+ 0.5		+ 0.6	ns	1-4	
t _{QHS}	Data hold skew factor		+ 0.75		+ 0.75		+ 1.0	ns	1-4	
t _{QH}	Data Output hold time from DQS	t _{HP} -t _{QHS}		t _{HP} -t _{QHS}		t _{HP} -t _{QHS}		ns	1-4	
t _{DQSL,H}	DQS input low (high) pulse width (write cycle)	0.35		0.35		0.35		t _{CK}	1-4	

1. Input slew rate ≥ 1V/ns for DDR266 and = 1V/ns for DDR200.
2. The CK/ \overline{CK} input reference level (for timing reference to CK/ \overline{CK}) is the point at which CK and \overline{CK} cross: the input reference level for signals other than CK/ \overline{CK} , is V_{REF}. CK/ \overline{CK} slew rate are ≥ 1.0 V/ns.
3. Inputs are not recognized as valid until V_{REF} stabilizes.
4. The Output timing reference level, as measured at the timing reference point indicated in AC Characteristics (Note 3) is V_{TT}.
5. t_{HZ} and t_{LZ} transitions occur in the same access time windows as valid data transitions. These parameters are not referred to a specific voltage level, but specify when the device is no longer driving (HZ), or begins driving (LZ).
6. The maximum limit for this parameter is not a device limit. The device operates with a greater value for this parameter, but system performance (bus turnaround) degrades accordingly.
7. The specific requirement is that DQS be valid (HIGH, LOW, or some point on a valid transition) on or before this CK edge. A valid transition is defined as monotonic and meeting the input slew rate specifications of the device. When no writes were previously in progress on the bus, DQS will be transitioning from Hi-Z to logic LOW. If a previous write was in progress, DQS could be HIGH, LOW, or transitioning from HIGH to LOW at this time, depending on t_{DQSS}.
8. A maximum of eight Autorefresh commands can be posted to any given DDR SDRAM device.
9. \overline{QFC} is enabled as soon as possible after the rising CK edge that registers the Write command.
10. \overline{QFC} is disabled as soon as possible after the last valid DQS edge transitions Low.
11. For each of the terms, if not already an integer, round to the next highest integer. t_{CK} is equal to the actual system clock cycle time.
12. These parameters guarantee device timing, but they are not necessarily tested on each device
13. Fast slew rate ≥ 1 V/ns, slow slew rate ≥ 0.5V/ns. For input setup & holdtime derating for slew rates less than 0.5 V/ns see JEDEC ballot JC-423-00-210, JCB-00-087, Item 1178.10

Electrical Characteristics & AC Timing for DDR266/DDR200 - Absolute Specifications

(0 °C ≤ T_A ≤ 70 °C; V_{DDQ} = 2.5V ± 0.2V; V_{DD} = 2.5V ± 0.2V, See AC Characteristics) (Part 2 of 3)

Symbol	Parameter	DDR266A -7		DDR266B -7.5		DDR200 -8		Unit	Notes
		Min	Max	Min	Max	Min	Max		
t _{DSS}	DQS falling edge to CK setup time (write cycle)	0.2		0.2		0.2		t _{CK}	1-4
t _{DSH}	DQS falling edge hold time from CK (write cycle)	0.2		0.2		0.2		t _{CK}	1-4
t _{MRD}	Mode register set command cycle time	14		15		16		ns	1-4
t _{WPRES}	Write preamble setup time	0		0		0		ns	1-4, 7
t _{WPST}	Write postamble	0.40	0.60	0.40	0.60	0.40	0.60	t _{CK}	1-4, 6
t _{WPRE}	Write preamble	0.25		0.25		0.25		t _{CK}	1-4
t _{IH}	Addr. and control input hold time (fast slew rate)	0.9		0.9		1.2		ns	1-4, 12,13
t _{IS}	Addr. and control input setup time (fast slew rate)	0.9		0.9		1.2		ns	
t _{IH}	Addr. and control input hold time (slow slew rate)	1.0		1.0		1.2		ns	
t _{IS}	Addr. and control input setup time (slow slew rate)	1.0		1.0		1.2		ns	
t _{RPRE}	Read preamble	0.9	1.1	0.9	1.1	0.9	1.1	t _{CK}	1-4
t _{RPST}	Read postamble	0.40	0.60	0.40	0.60	0.40	0.60	t _{CK}	1-4
t _{RAS}	Active to Precharge command	45	120,000	45	120,000	50	120,000	ns	1-4
t _{RC}	Active to Active/Auto-refresh command period	65		65		70		ns	1-4
t _{RFC}	Auto-refresh to Active/Auto-refresh command period	75		75		80		ns	1-4
t _{RCD}	Active to Read or Write delay	20		20		20		ns	1-4
t _{RP}	Precharge command period	20		20		20		ns	1-4
t _{R RD}	Active bank A to Active bank B command	15		15		15		ns	1-4
t _{WR}	Write recovery time	15		15		15		ns	1-4

1. Input slew rate ≥ 1V/ns for DDR266 and = 1V/ns for DDR200.
2. The CK/CK̄ input reference level (for timing reference to CK/CK̄) is the point at which CK and CK̄ cross: the input reference level for signals other than CK/CK̄, is V_{REF}. CK/CK̄ slew rate are ≥ 1.0 V/ns.
3. Inputs are not recognized as valid until V_{REF} stabilizes.
4. The Output timing reference level, as measured at the timing reference point indicated in AC Characteristics (Note 3) is V_{TT}.
5. t_{HZ} and t_{LZ} transitions occur in the same access time windows as valid data transitions. These parameters are not referred to a specific voltage level, but specify when the device is no longer driving (HZ), or begins driving (LZ).
6. The maximum limit for this parameter is not a device limit. The device operates with a greater value for this parameter, but system performance (bus turnaround) degrades accordingly.
7. The specific requirement is that DQS be valid (HIGH, LOW, or some point on a valid transition) on or before this CK edge. A valid transition is defined as monotonic and meeting the input slew rate specifications of the device. When no writes were previously in progress on the bus, DQS will be transitioning from Hi-Z to logic LOW. If a previous write was in progress, DQS could be HIGH, LOW, or transitioning from HIGH to LOW at this time, depending on t_{DQSS}.
8. A maximum of eight Autorefresh commands can be posted to any given DDR SDRAM device.
9. QFC is enabled as soon as possible after the rising CK edge that registers the Write command.
10. QFC is disabled as soon as possible after the last valid DQS edge transitions Low.
11. For each of the terms, if not already an integer, round to the next highest integer. t_{CK} is equal to the actual system clock cycle time.
12. These parameters guarantee device timing, but they are not necessarily tested on each device
13. Fast slew rate ≥ 1 V/ns, slow slew rate ≥ 0.5V/ns. For input setup & holdtime derating for slew rates less than 0.5 V/ns see JEDEC ballot JC-423-00-210, JCB-00-087, Item 1178.10

Electrical Characteristics & AC Timing for DDR266/DDR200 - Absolute Specifications

(0 °C ≤ T_A ≤ 70 °C; V_{DDQ} = 2.5V ± 0.2V; V_{DD} = 2.5V ± 0.2V, See AC Characteristics) (Part 3 of 3)

Symbol	Parameter	DDR266A -7		DDR266B -7.5		DDR200 -8		Unit	Notes
		Min	Max	Min	Max	Min	Max		
t _{DAL}	Auto precharge write recovery + precharge time	(twr/tck + (trp/tck))						t _{CK}	1-4,11
t _{WTR}	Internal write to read command delay	1		1		1		t _{CK}	1-4
t _{XSNR}	Exit self-refresh to non-read command	75		75		80		ns	1-4
t _{XSRD}	Exit self-refresh to read command	200		200		200		t _{CK}	1-4
t _{REFI}	Average Periodic Refresh Interval		7.8		7.8		7.8	μs	1-4, 8
t _{QPRE}	\overline{QFC} preamble during reads	0.9	1.1	0.9	1.1	0.9	1.1	t _{CK}	1-,12
t _{QPST}	\overline{QFC} postamble during reads	0.4	0.6	0.4	0.6	0.4	0.6	t _{CK}	1-,12
t _{QCK}	\overline{QFC} output access time form CK/ \overline{CK} , for writes		4.0		4.0		4.0	ns	1-4, 9, 12
t _{QOH}	\overline{QFC} output hold time for writes	1.25	2.0	1.25	2.0	1.25	2.0	ns	1-4, 10,12

1. Input slew rate ≥ 1V/ns for DDR266 and = 1V/ns for DDR200.
2. The CK/ \overline{CK} input reference level (for timing reference to CK/ \overline{CK}) is the point at which CK and \overline{CK} cross: the input reference level for signals other than CK/ \overline{CK} , is V_{REF}. CK/ \overline{CK} slew rate are ≥ 1.0 V/ns.
3. Inputs are not recognized as valid until V_{REF} stabilizes.
4. The Output timing reference level, as measured at the timing reference point indicated in AC Characteristics (Note 3) is V_{TT}.
5. t_{HZ} and t_{LZ} transitions occur in the same access time windows as valid data transitions. These parameters are not referred to a specific voltage level, but specify when the device is no longer driving (HZ), or begins driving (LZ).
6. The maximum limit for this parameter is not a device limit. The device operates with a greater value for this parameter, but system performance (bus turnaround) degrades accordingly.
7. The specific requirement is that DQS be valid (HIGH, LOW, or some point on a valid transition) on or before this CK edge. A valid transition is defined as monotonic and meeting the input slew rate specifications of the device. When no writes were previously in progress on the bus, DQS will be transitioning from Hi-Z to logic LOW. If a previous write was in progress, DQS could be HIGH, LOW, or transitioning from HIGH to LOW at this time, depending on t_{DQSS}.
8. A maximum of eight Autorefresh commands can be posted to any given DDR SDRAM device.
9. \overline{QFC} is enabled as soon as possible after the rising CK edge that registers the Write command.
10. \overline{QFC} is disabled as soon as possible after the last valid DQS edge transitions Low.
11. For each of the terms, if not already an integer, round to the next highest integer. t_{CK} is equal to the actual system clock cycle time.
12. These parameters guarantee device timing, but they are not necessarily tested on each device
13. Fast slew rate ≥ 1 V/ns, slow slew rate ≥ 0.5V/ns. For input setup & holdtime derating for slew rates less than 0.5 V/ns see JEDEC ballot JC-423-00-210, JCB-00-087, Item 1178.10

Electrical Characteristics & AC Timing for DDR266B - Applicable Specifications Expressed in Clock Cycles ($0\text{ }^{\circ}\text{C} \leq T_A \leq 70\text{ }^{\circ}\text{C}$; $V_{DDQ} = 2.5\text{V} \pm 0.2\text{V}$; $V_{DD} = 2.5\text{V} \pm 0.2\text{V}$, See AC Characteristics)

Symbol	Parameter	DDR266B @ CL=2.5		Units	Notes
		Min	Max		
t_{MRD}	Mode register set command cycle time	2		t_{CK}	1-5
t_{WPRE}	Write preamble	0.25		t_{CK}	1-5
t_{RAS}	Active to Precharge command	6	16000	t_{CK}	1-5
t_{RC}	Active to Active/Auto-refresh command period	9		t_{CK}	1-5
t_{RFC}	Auto-refresh to Active/Auto-refresh command period	10		t_{CK}	1-5
t_{RCD}	Active to Read or Write delay	3		t_{CK}	1-5
t_{RP}	Precharge command period	3		t_{CK}	1-45
t_{RRD}	Active bank A to Active bank B command	2		t_{CK}	1-5
t_{WR}	Write recovery time	2		t_{CK}	1-5
t_{DAL}	Auto precharge write recovery + precharge time	5		t_{CK}	1-5
t_{WTR}	Internal write to read command delay	1		t_{CK}	1-5
t_{XSNR}	Exit self-refresh to non-read command	10		t_{CK}	1-5
t_{XSRD}	Exit self-refresh to read command	200		t_{CK}	1-5

1. Input slew rate = 1V/ns
2. The CK/ \overline{CK} input reference level (for timing reference to CK/ \overline{CK}) is the point at which CK and \overline{CK} cross: the input reference level for signals other than CK/ \overline{CK} , is V_{REF} .
3. Inputs are not recognized as valid until V_{REF} stabilizes.
4. The Output timing reference level, as measured at the timing reference point indicated in AC Characteristics (Note 3) is V_{TT} .
5. t_{HZ} and t_{LZ} transitions occur in the same access time windows as valid data transitions. These parameters are not referred to a specific voltage level, but specify when the device is no longer driving (HZ), or begins driving (LZ).

Data Input (Write) (Timing Burst Length = 4)

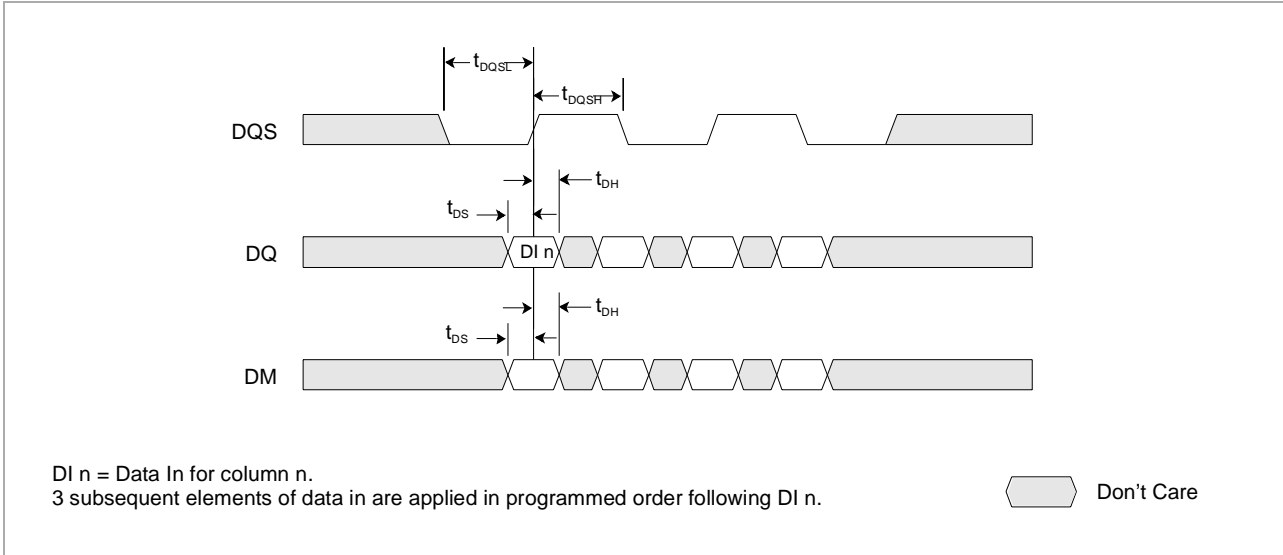

Data Output (Read) (Timing Burst Length = 4)

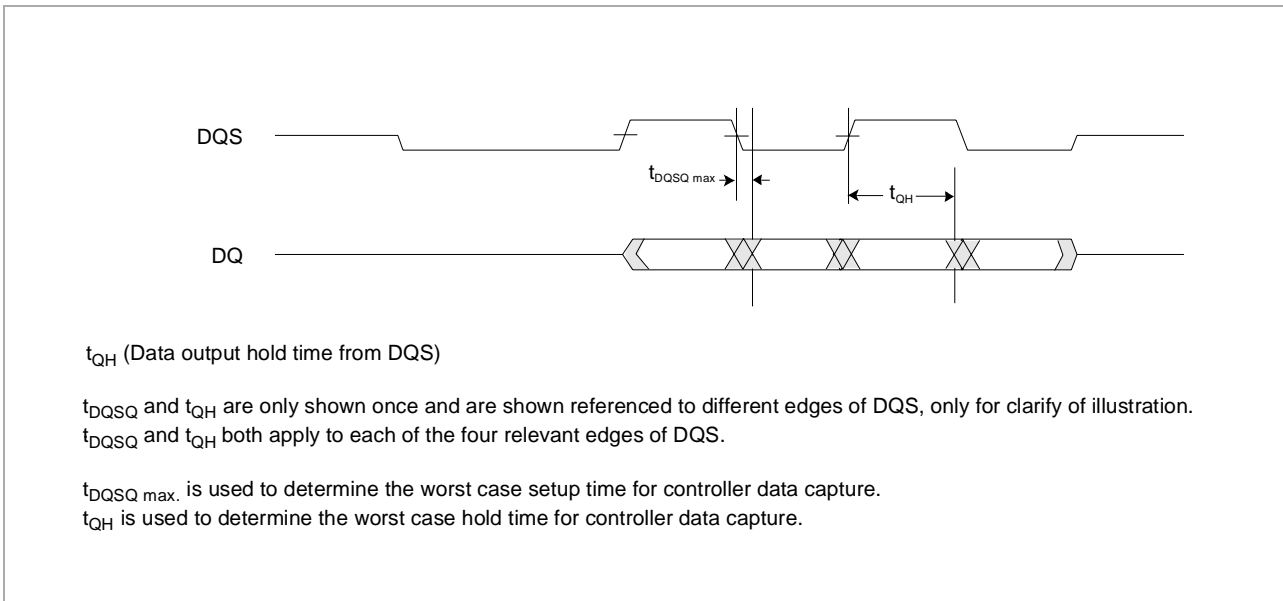



HYB25D256400/800T/AT
256-Mbit Double Data Rate SDRAM

Initialize and Mode Register Sets

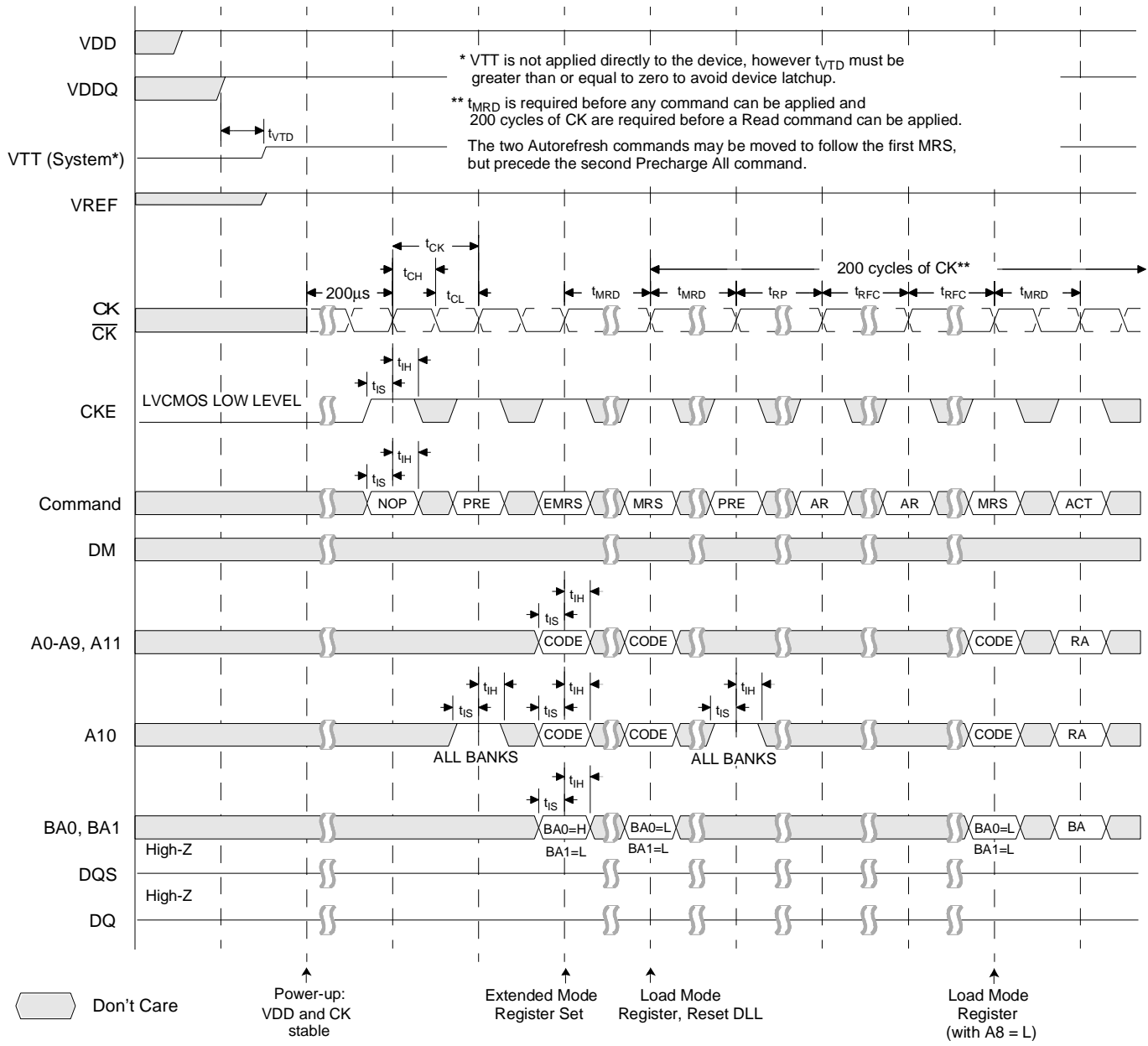

Power Down Mode

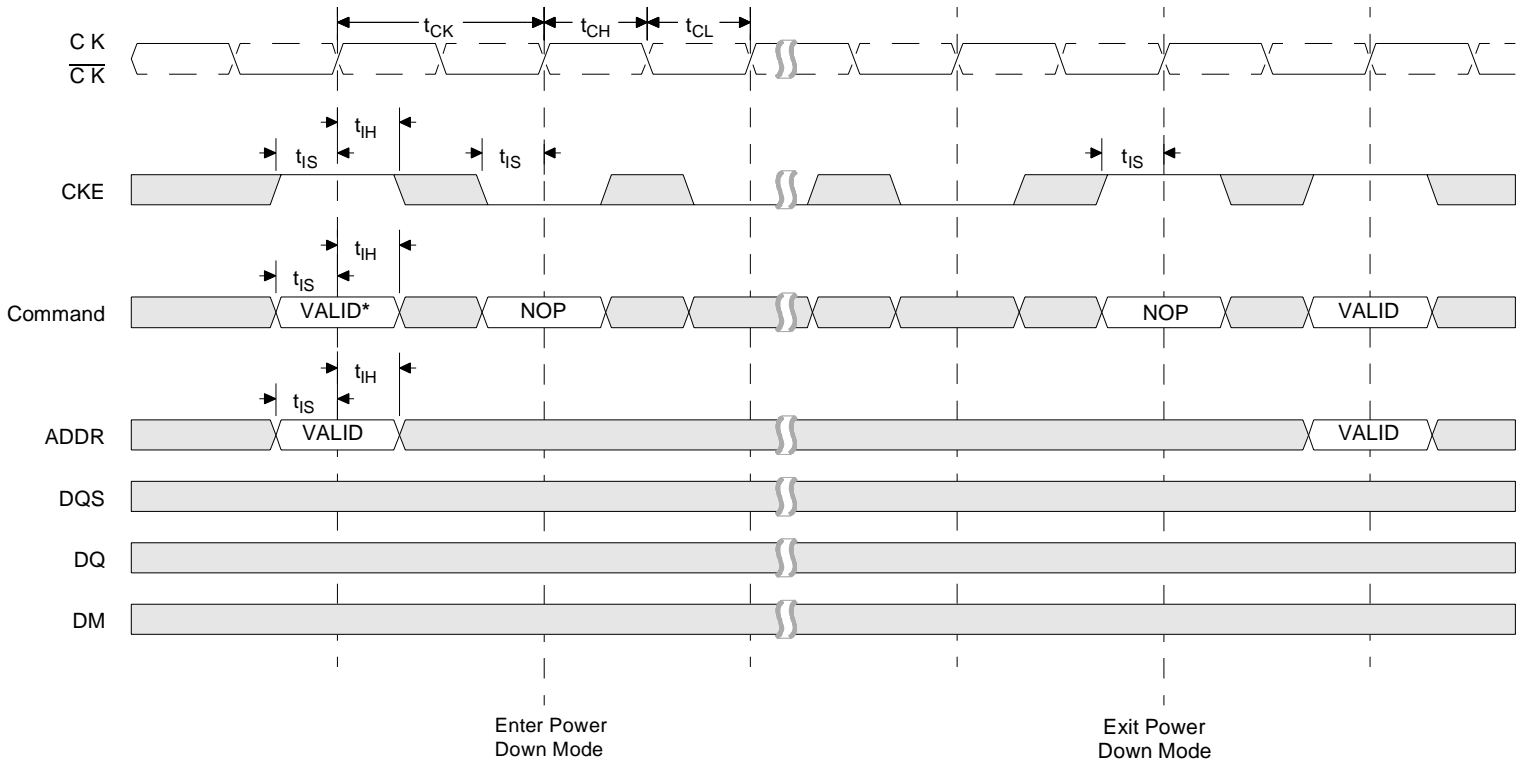

No column accesses are allowed to be in progress at the time power down is entered.

* = If this command is a Precharge (or if the device is already in the idle state) then the power down mode shown is Precharge power down. If this command is an Active (or if at least one row is already active), then the power down mode shown is Active power down.

Don't Care

Auto Refresh Mode

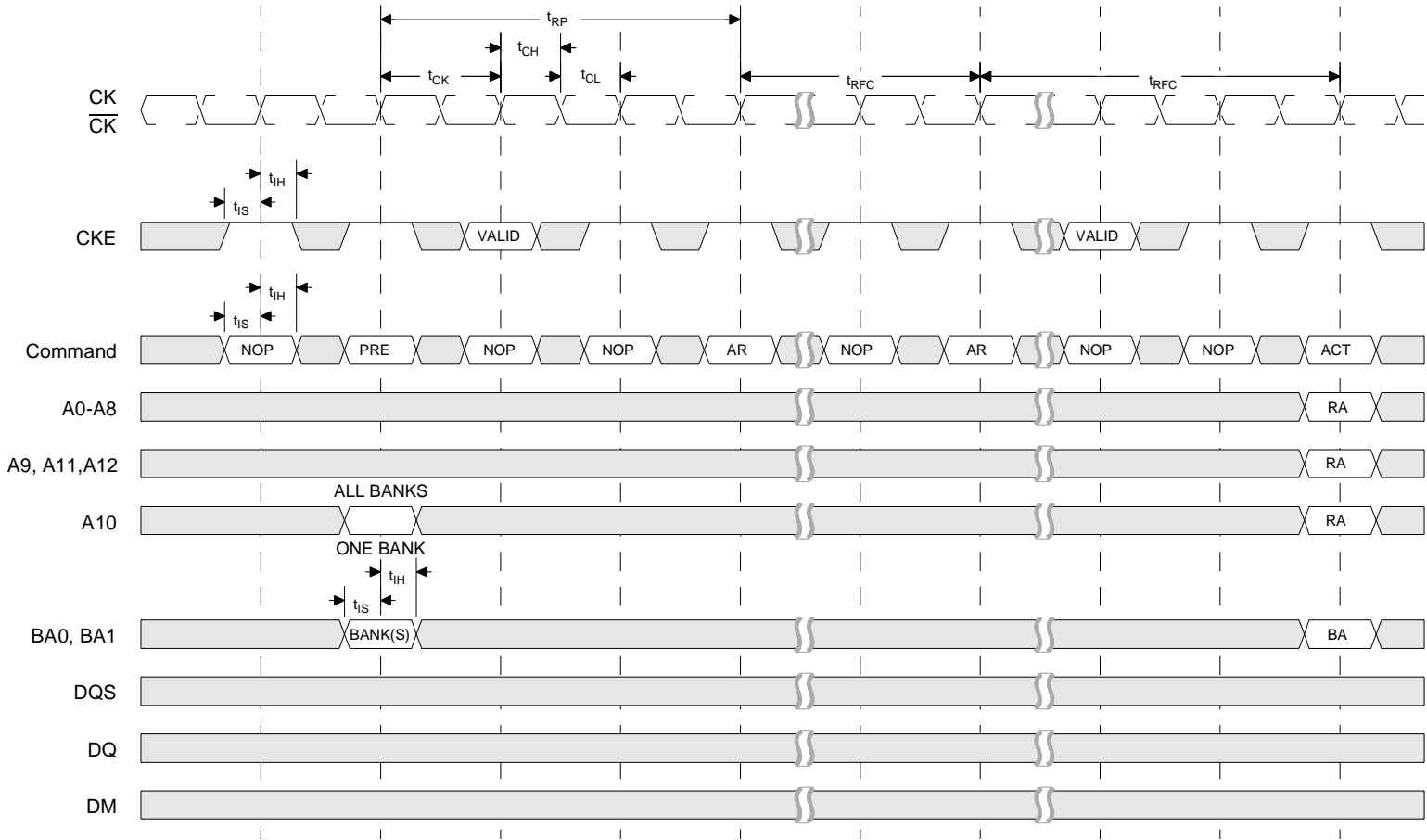

PRE = Precharge; ACT = Active; RA = Row address; BA = Bank address; AR = Autorefresh.
NOP commands are shown for ease of illustration; other valid commands may be possible at these times.
DM, DQ, and DQS signals are all don't care/high-Z for operations shown.

Don't Care

Self Refresh Mode

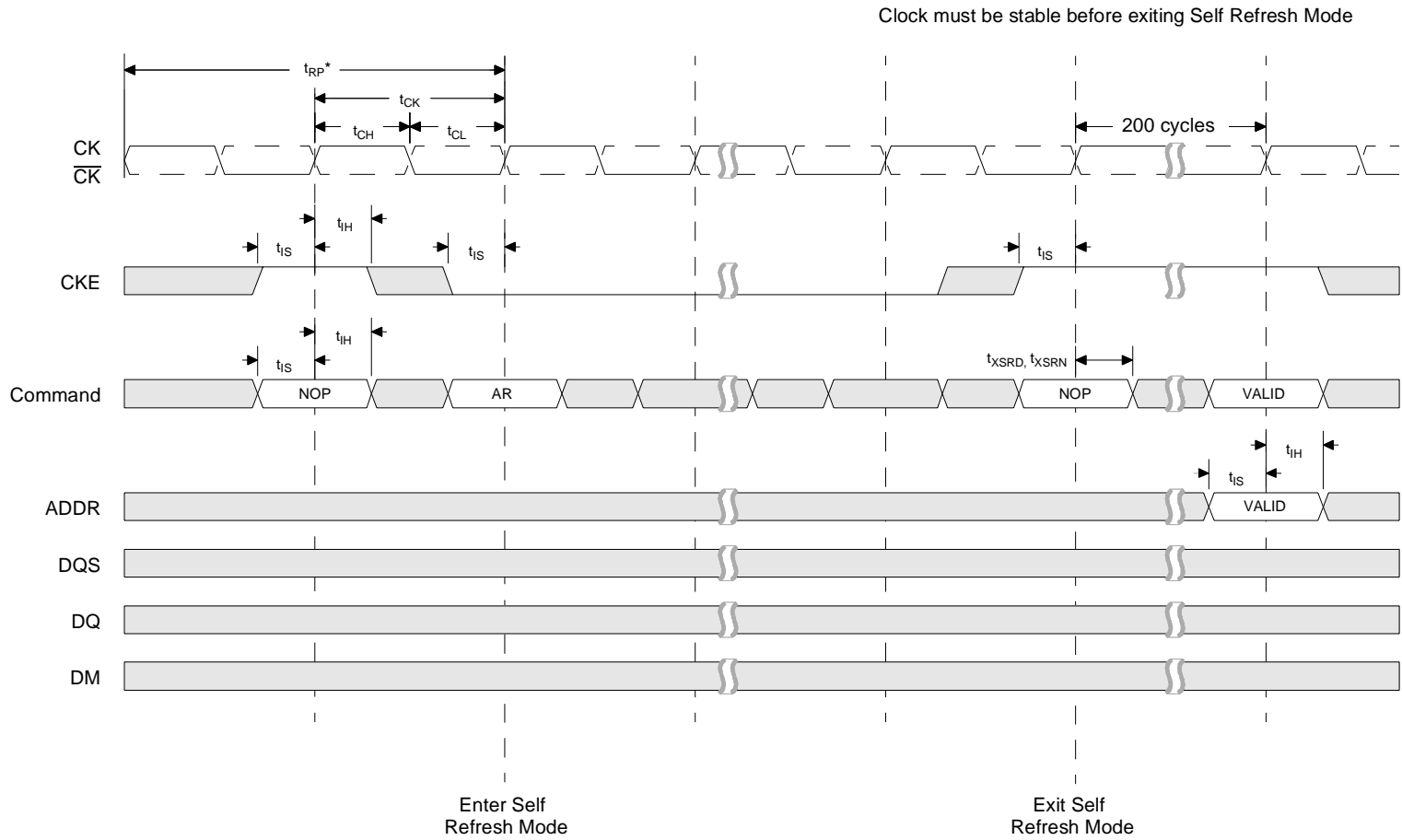

* = Device must be in the all banks idle state before entering Self Refresh Mode.
 ** = t_{XSNR} is required before any non-read command can be applied, and t_{XSRD} (200 cycles of CK) are required before a Read command can be applied.

Don't Care

Read without Auto Precharge (Burst Length = 4)

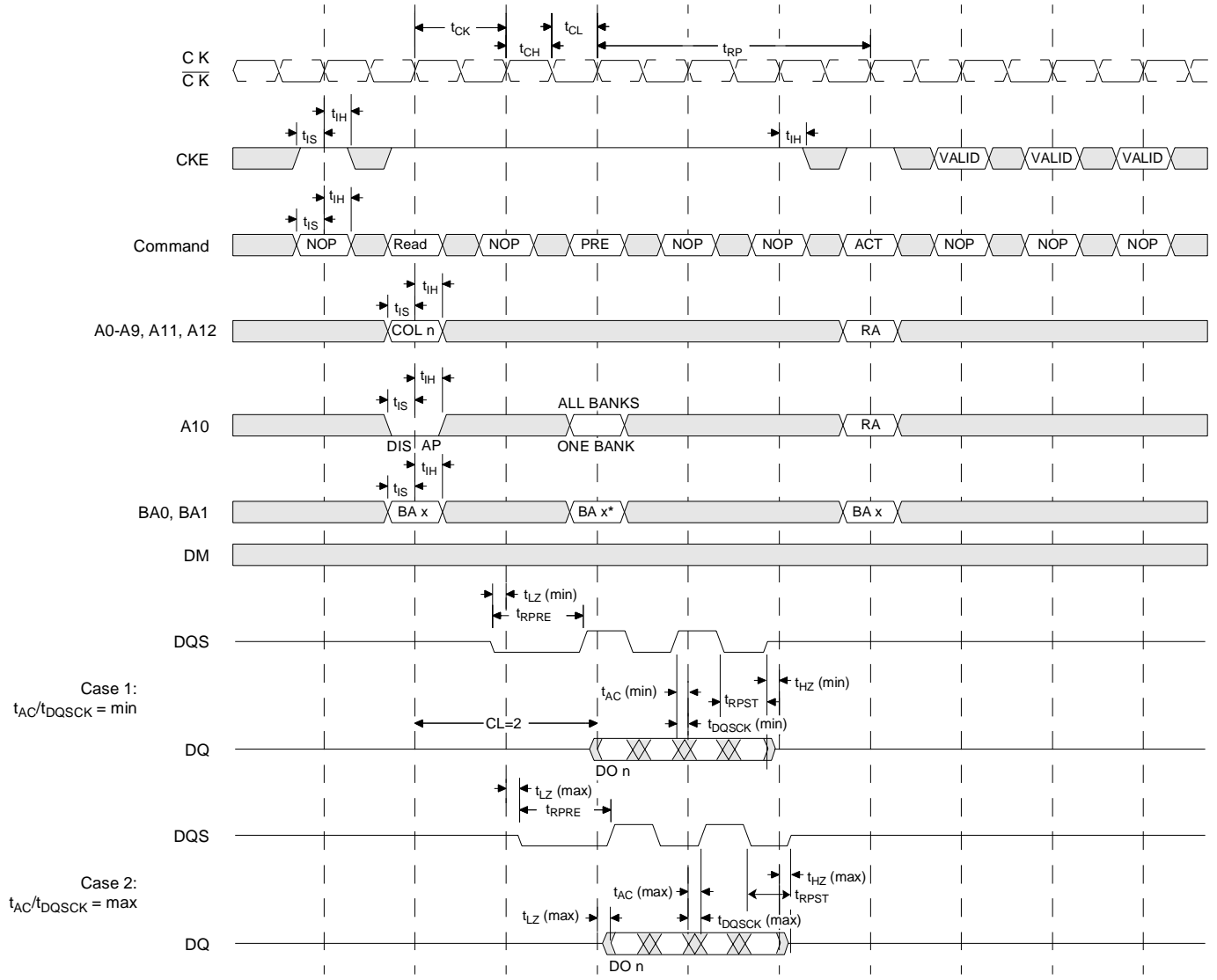

DO n = data out from column n.
 3 subsequent elements of data out are provided in the programmed order following DO n.
 DIS AP = Disable Auto Precharge.
 * = Don't care if A10 is High at this point.
 PRE = Precharge; ACT = Active; RA = Row address; BA = Bank address.
 NOP commands are shown for ease of illustration; other commands may be valid at these times.

Don't Care

Read with Auto Precharge (Burst Length = 4)

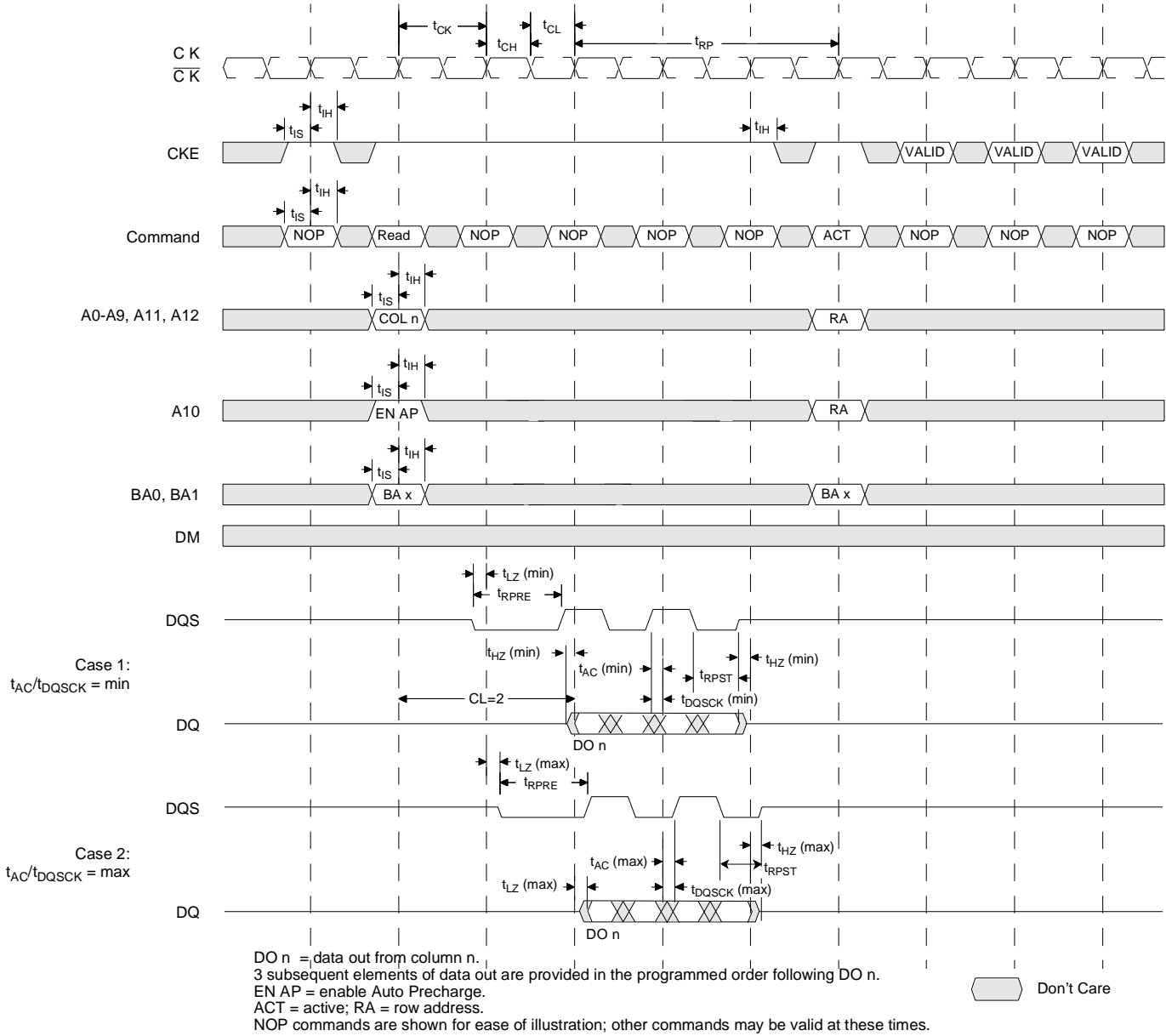

Bank Read Access (Burst Length = 4)

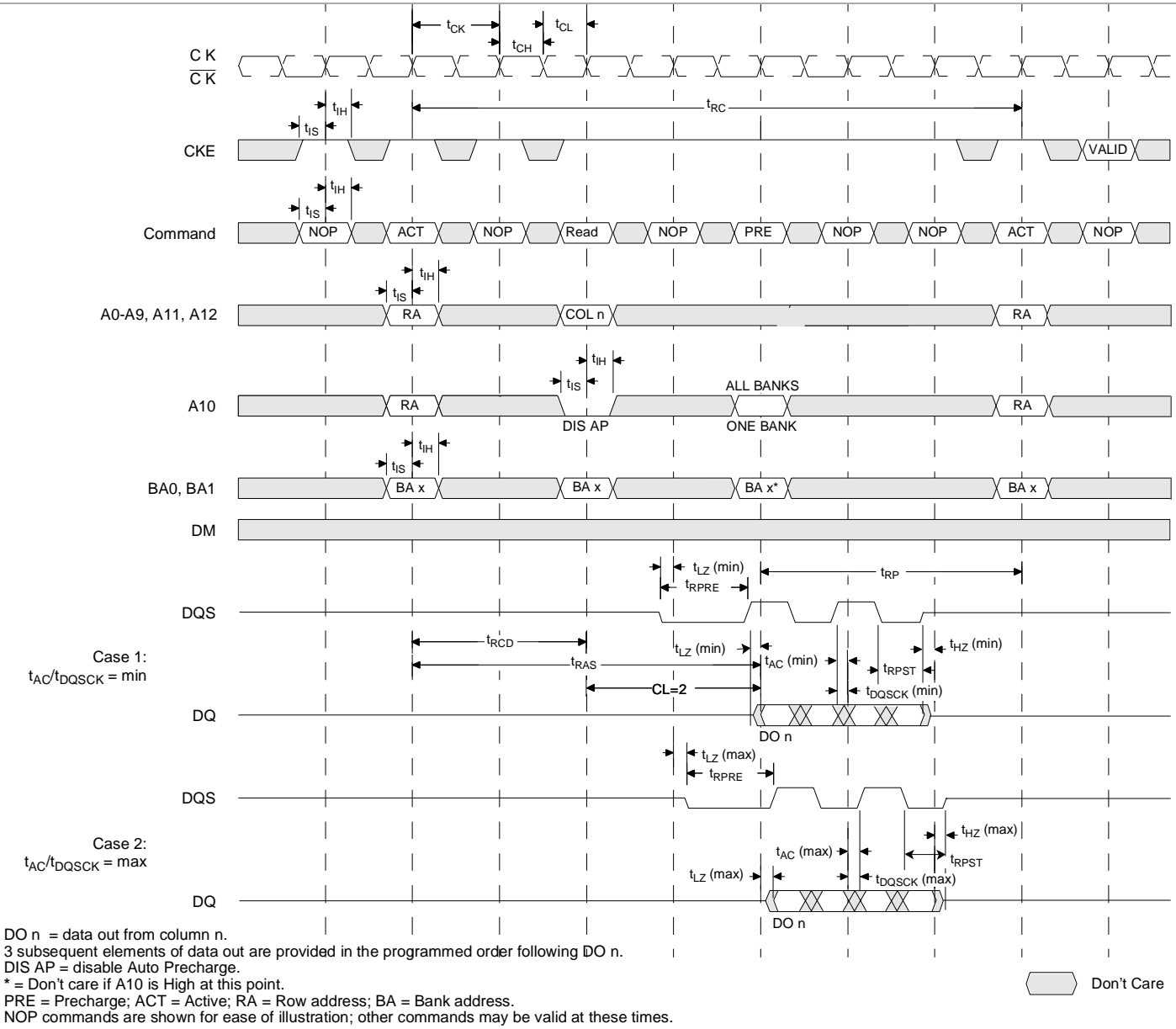

DO n = data out from column n.
 3 subsequent elements of data out are provided in the programmed order following DO n.
 DIS AP = disable Auto Precharge.
 * = Don't care if A10 is High at this point.
 PRE = Precharge; ACT = Active; RA = Row address; BA = Bank address.
 NOP commands are shown for ease of illustration; other commands may be valid at these times.

Don't Care

Write without Auto Precharge (Burst Length = 4)

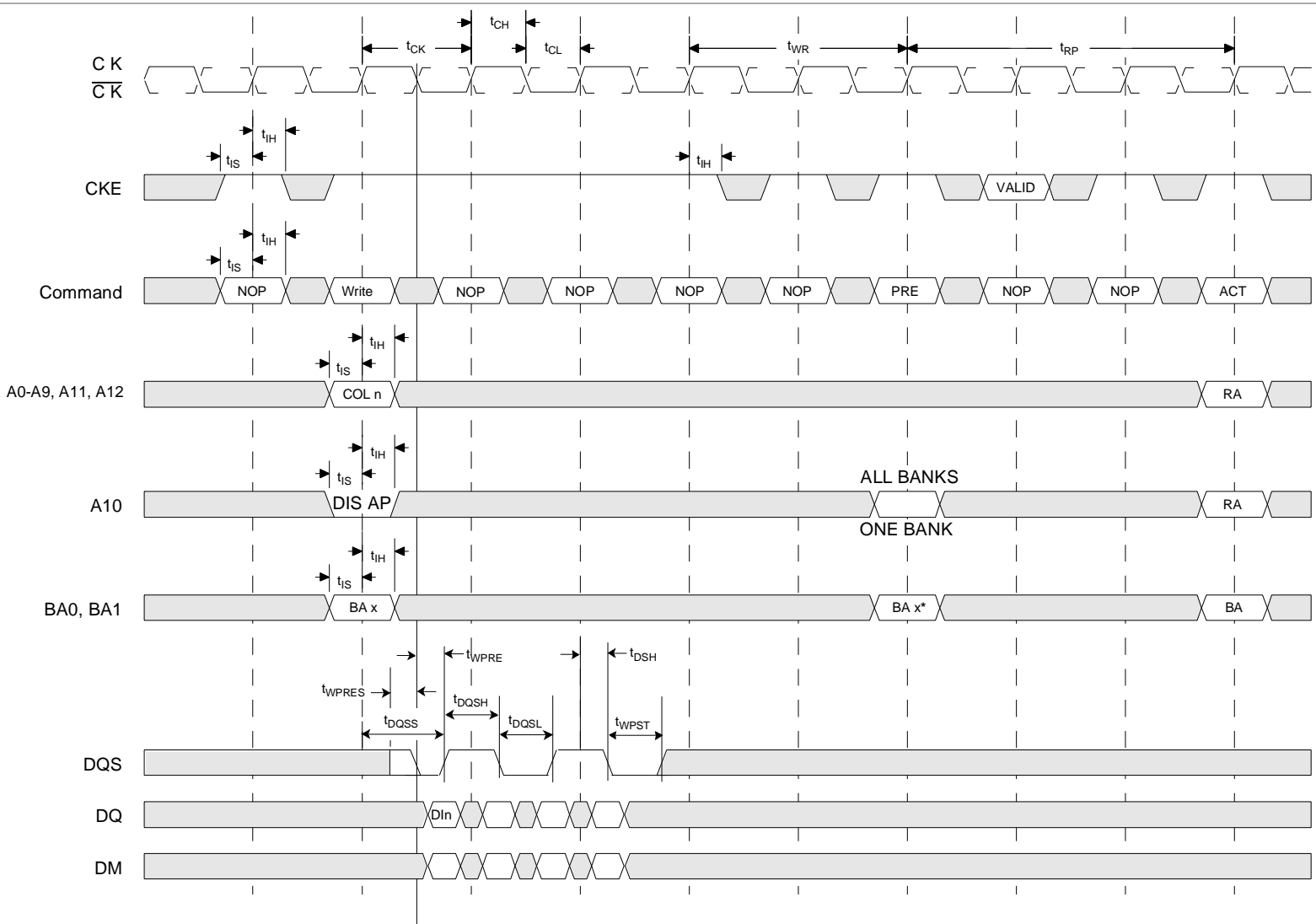

$t_{DQSS} = \min.$
 D_{In} = Data in for column n.
 3 subsequent elements of data in are applied in the programmed order following D_{In} .
 DIS AP = Disable Auto Precharge.
 * = Don't care if A10 is High at this point.
 PRE = Precharge; ACT = Active; RA = Row address; BA = Bank address.
 NOP commands are shown for ease of illustration; other valid commands may be possible at these times.

Don't Care

Write with Auto Precharge (Burst Length = 4)

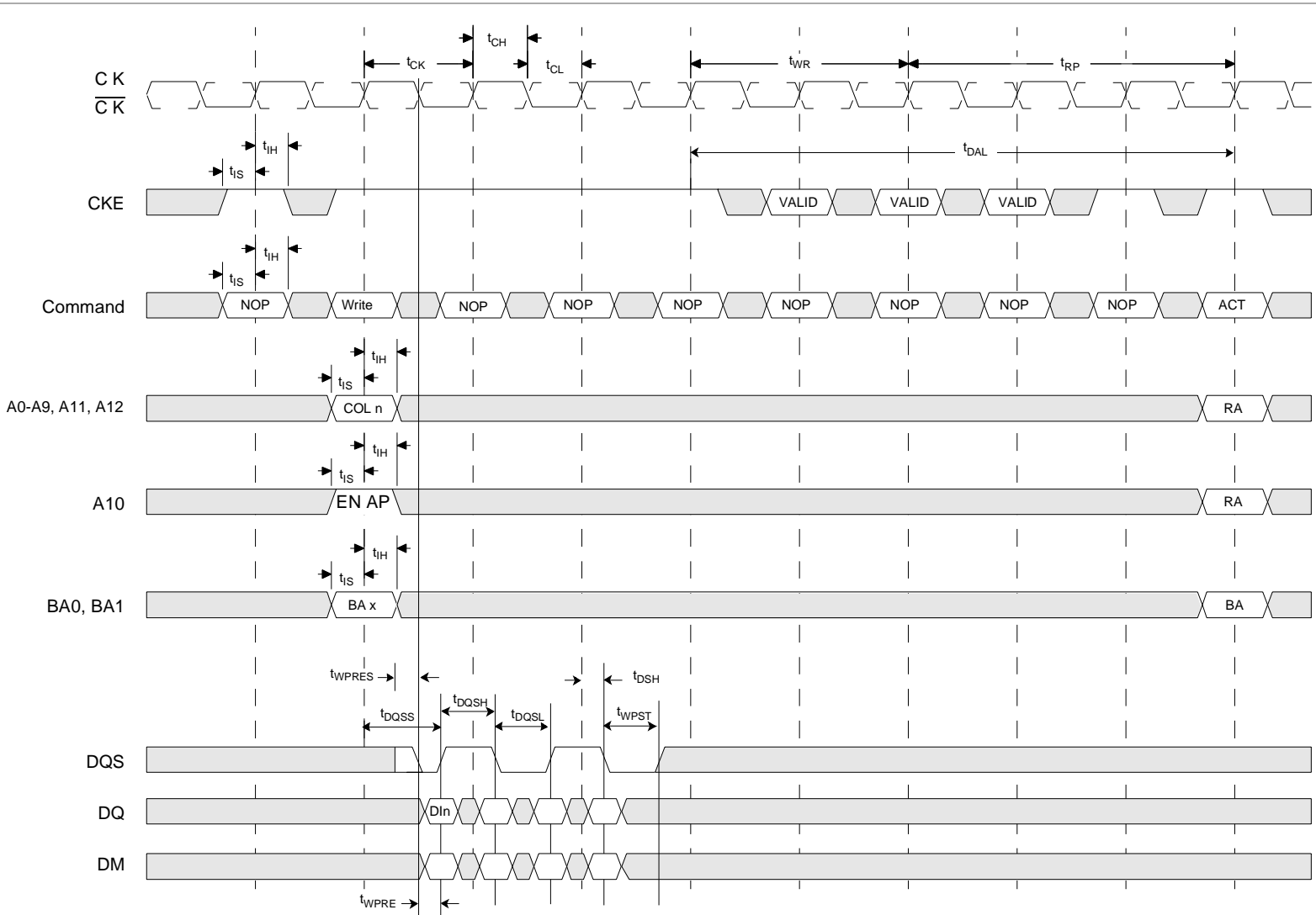

$t_{DQSS} = \text{min.}$
 D_{In} = Data in for column n.
 3 subsequent elements of data in are applied in the programmed order following D_{In} .
 EN AP = Enable Auto Precharge.
 ACT = Active; RA = Row address; BA = Bank address.
 NOP commands are shown for ease of illustration; other valid commands may be possible at these times.

Don't Care



Bank Write Access (Burst Length = 4)

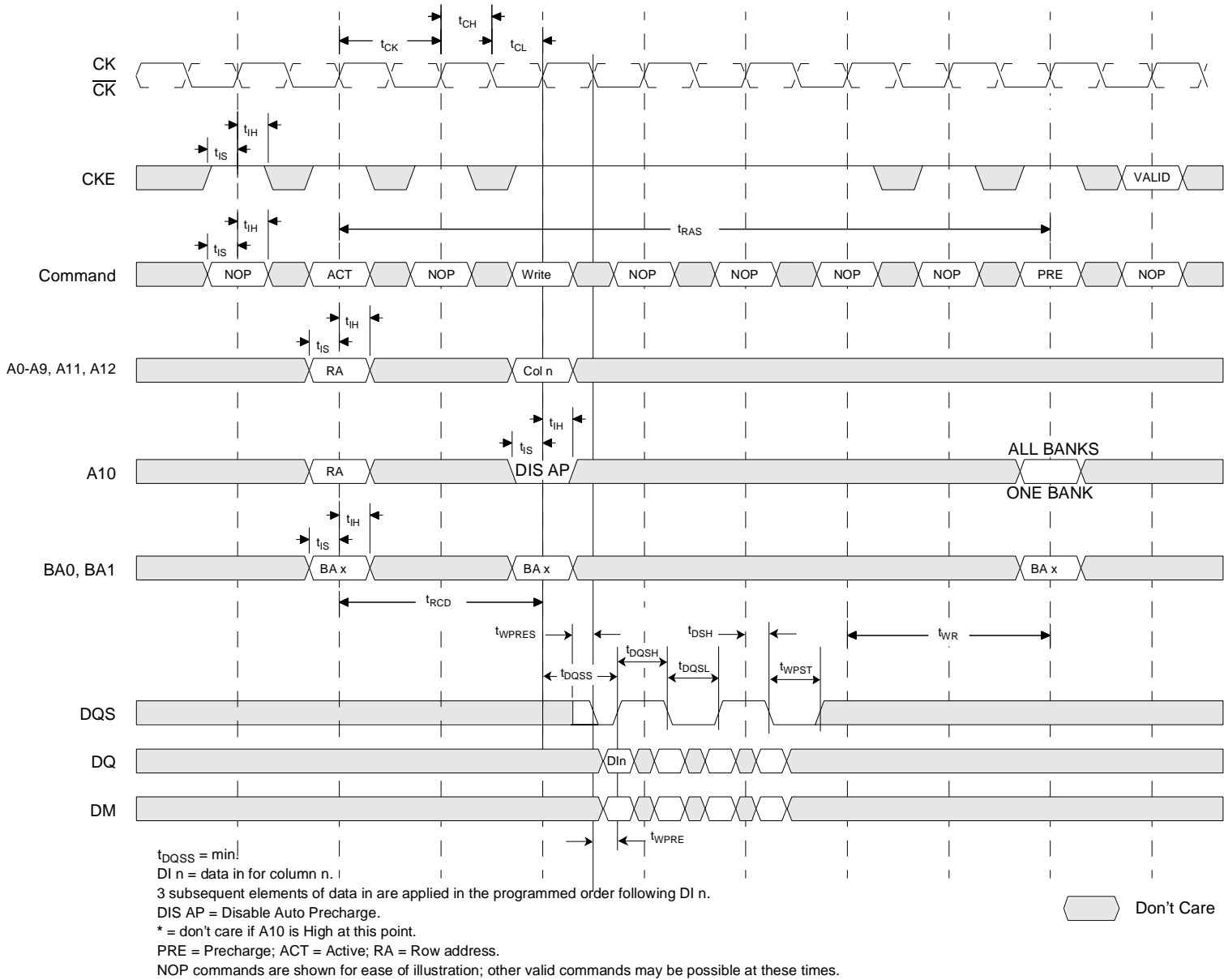

Package Dimensions (400mil; 66 lead; Thin Small Outline Package)

Plastic Package, P-TSOPII-66
 (400mil; 66 lead)
 Thin Small Outline Package

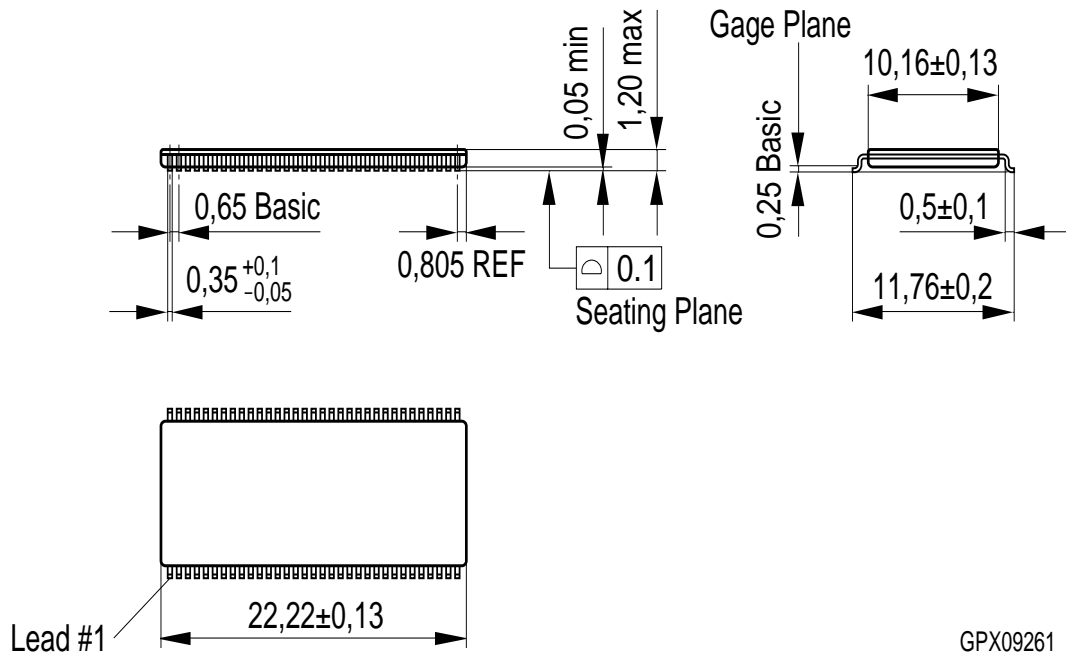

Attention please !

As far as patents or other rights of third parties are concerned, liability is only assumed for components, not for applications, processes and circuits implemented within components or assemblies. This information describes the type of components and shall not be considered as assured characteristics. Terms of delivery and rights to change design reserved.

For questions on technology, delivery and prices please contact INFINEON Technologies Offices in Munich or the INFINEON Technologies Sales Offices and Representatives worldwide.

Due to technical requirements components may contain dangerous substances. For information on the types in question please contact your nearest INFINEON Technologies office or representative.

Packing

Please use the recycling operators known to you. We can help you - get in touch with your nearest sales office. By agreement we will take packing material back, if it is sorted. You must bear the costs of transport. For packing material that is returned to us unsorted or which we are not obliged to accept, we shall have to invoice you for any costs incurred.

Components used in life-support devices or systems must be expressly authorized for such purpose!

Critical components¹ of INFINEON Technologies, may only be used in life-support devices or systems² with the express written approval of INFINEON Technologies.

1. A critical component is a component used in a life-support device or system whose failure can reasonably be expected to cause the failure of that life-support device or system, or to affect its safety or effectiveness of that device or system.
2. Life support devices or systems are intended (a) to be implanted in the human body, or (b) to support and/or maintain and sustain human life. If they fail, it is reasonable to assume that the health of the user may be endangered.