

**Surface Mount
unidirectional and bidirectional
Transient Voltage Suppressor Diodes**

**Unidirektionale und bidirektionale
Spannungs-Begrenzer-Dioden
für die Oberflächenmontage**

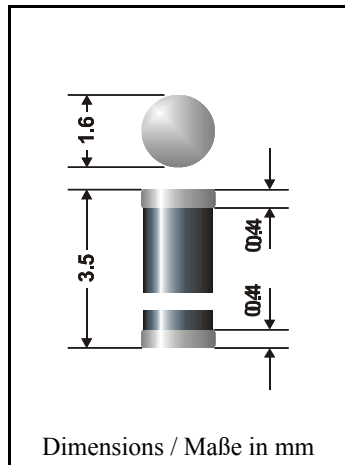

Pulse power dissipation – Impuls-Verlustleistung	150 W
Nominal breakdown voltage Nominale Abbruch-Spannung	6.8...200 V
Plastic case MiniMELF Kunststoffgehäuse MiniMELF	SOD-80 DO-213AA
Weight approx. – Gewicht ca.	0.04 g
Plastic material has UL classification 94V-0 Gehäusematerial UL94V-0 klassifiziert	
Standard packaging taped in ammo pack Standard Lieferform gegurtet in Ammo-Pack	see page 18 siehe Seite 18

Marking: One blue ring denotes “cathode” and “TVS-Diode family”
The type numbers are noted only on the label on the reel

Kennzeichnung: Ein blauer Ring kennzeichnet “Kathode” und “TVS-Dioden-Familie”
Die Typenbezeichnungen sind nur auf dem Rollenaufkleber vermerkt

Maximum ratings and Characteristics

Grenz- und Kennwerte

Peak pulse power dissipation (10/1000 μ s waveform) Impuls-Verlustleistung (Strom-Impuls 10/1000 μ s)	$T_A = 25^\circ\text{C}$	P_{PPM}	150 W ¹⁾
Steady state power dissipation Verlustleistung im Dauerbetrieb	$T_A = 25^\circ\text{C}$	$P_{\text{M(AV)}}$	500 mW ²⁾
Peak forward surge current, 60 Hz half sine-wave Stoßstrom für eine 60 Hz Sinus-Halbwellen	$T_A = 25^\circ\text{C}$	I_{FSM}	20 A ³⁾
Max. instantaneous forward voltage Augenblickswert der Durchlaßspannung	$I_F = 10\text{A}$	V_F	< 3.5 V ³⁾
Operating junction temperature – Sperrschichttemperatur Storage temperature – Lagerungstemperatur		T_j T_s	– 50...+150°C – 50...+150°C
Thermal resistance junction to ambient air Wärmewiderstand Sperrschicht – umgebende Luft		R_{thA}	< 150 K/W ²⁾
Thermal resistance junction to terminal Wärmewiderstand Sperrschicht – Kontaktfläche		R_{thT}	< 60 K/W

¹⁾ Non-repetitive current pulse see curve $I_{\text{PPM}} = f(t_r)$
Höchstzulässiger Spitzenwert eines einmaligen Strom-Impulses, siehe Kurve $I_{\text{PPM}} = f(t_r)$

²⁾ Mounted on P.C. board with 25 mm² copper pads at each terminal
Montage auf Leiterplatte mit 25 mm² Kupferbelag (Löt-pad) an jedem Anschluß

³⁾ Unidirectional diodes only – nur für unidirektionale Dioden

Maximum ratings
Grenzwerte

Type Typ	Breakdown voltage at $I_T = 1$ mA Abbruch-Spannung bei $I_T = 1$ mA) at / bei $I_T = 10$ mA		Max. stand-off voltage Max. Sperrspannung at / bei I_D		Max. clamping voltage Max. Begrenzerspannung at / bei I_{PPM} (10/1000 μ s)	
	V_{BR} [V]		V_{WM} [V]	I_D [μ A]	V_C [V]	I_{PPM} [A]
TGL34-6.8	6.8 \pm 10%	6.12...7.48 *)	5.5	1000	10.8	13,9
TGL34-6.8A	6.8 \pm 5%	6.45...7.14 *)	5.8	1000	10.5	14,3
TGL34-7.5	7.5 \pm 10%	6.75...8.25 *)	6.0	500	11.7	12,8
TGL34-7.5A	7.5 \pm 5%	7.13...7.88 *)	6.4	500	11.3	13,3
TGL34-8.2	8.2 \pm 10%	7.38...9.02 *)	6.6	200	12.5	12,0
TGL34-8.2A	8.2 \pm 5%	7.79...8.61 *)	7.0	200	12.1	12,4
TGL34 9.1	9.1 \pm 10%	8.19...10.0	7.3	50	13.8	10,9
TGL34-9.1A	9.1 \pm 5%	8.65...9.55	7.7	50	13.4	11,2
TGL34-10	10 \pm 10%	9.0...11.0	8.1	10	15.0	10,0
TGL34-10A	10 \pm 5%	9.5...10.5	8.5	10	14.5	10,3
TGL34-11	11 \pm 10%	9.9...12.1	8.9	5	16.2	9,3
TGL34-11A	11 \pm 5%	10.5...11.6	9.4	5	15.6	9,6
TGL34-12	12 \pm 10%	10.8...13.2	9.7	5	17.3	8,7
TGL34-12A	12 \pm 5%	11.4...12.6	10.2	5	16.7	9,0
TGL34-13	13 \pm 10%	11.7...14.3	10.5	5	19.0	7,9
TGL34-13A	13 \pm 5%	12.4...13.7	11.1	5	18.2	8,2
TGL34-15	15 \pm 10%	13.5...16.5	12.1	5	22.0	6,8
TGL34-15A	15 \pm 5%	14.3...15.8	12.8	5	21.2	7,1
TGL34-16	16 \pm 10%	14.4...17.6	12.9	5	23.5	6,4
TGL34-16A	16 \pm 5%	15.2...16.8	13.6	5	22.5	6,7
TGL34-18	18 \pm 10%	16.2...19.8	14.5	5	26.5	5,7
TGL34-18A	18 \pm 5%	17.1...18.9	15.3	5	25.5	5,9
TGL34-20	20 \pm 10%	18.0...22.0	16.2	5	29.1	5,2
TGL34-20A	20 \pm 5%	19.0...21.0	17.1	5	27.7	5,4
TGL34-22	22 \pm 10%	19.8...24.2	17.8	5	31.9	4,7
TGL34-22A	22 \pm 5%	20.9...23.1	18.8	5	30.6	4,9
TGL34-24	24 \pm 10%	21.6...26.4	19.4	5	34.7	4,3
TGL34-24A	24 \pm 5%	22.8...25.2	20.5	5	33.2	4,5
TGL34-27	27 \pm 10%	24.3...29.7	21.8	5	39.1	3,8
TGL34-27A	27 \pm 5%	25.7...28.4	23.1	5	37.5	4,0
TGL34-30	30 \pm 10%	27.0...33.0	24.3	5	43.5	3,4
TGL34-30A	30 \pm 5%	28.5...31.5	25.6	5	41.4	3,6
TGL34-33	33 \pm 10%	29.7...36.3	26.8	5	47.7	3,1
TGL34-33A	33 \pm 5%	31.4...34.7	28.2	5	45.7	3,3
TGL34-36	36 \pm 10%	32.4...39.6	29.1	5	52.0	2,9
TGL34-36A	36 \pm 5%	34.2...37.8	30.8	5	49.9	3,0
TGL34-39	39 \pm 10%	35.1...42.9	31.6	5	56.4	2,7
TGL34-39A	39 \pm 5%	37.1...41.0	33.3	5	53.9	2,8

For bidirectional types (suffix "C" or "CA") electrical characteristics apply in both directions

Maximum ratings**Grenzwerte**

Type Typ	Breakdown voltage at $I_T = 1$ mA Abbruch-Spannung bei $I_T = 1$ mA		Max. stand-off voltage Max. Sperrspannung at / bei I_D		Max. clamping voltage Max. Begrenzerspannung at / bei I_{PPM} (10/1000 μ s)	
	V_{BR} [V]		V_{WM} [V]	I_D [μ A]	V_C [V]	I_{PPM} [A]
TGL34-43	43 \pm 10%	38.7...47.3	34.8	5	61.9	2,4
TGL34-43A	43 \pm 5%	40.9...45.2	36.8	5	59.3	2,5
TGL34-47	47 \pm 10%	42.3...51.7	38.1	5	67.8	2,2
TGL34-47A	47 \pm 5%	44.7...49.4	40.2	5	64.8	2,3
TGL34-51	51 \pm 10%	45.9...56.1	41.3	5	73.5	2,0
TGL34-51A	51 \pm 5%	48.5...53.6	43.6	5	70.1	2,1
TGL34-56	56 \pm 10%	50.4...61.6	45.4	5	80.5	1,9
TGL34-56A	56 \pm 5%	53.2...58.8	43.6	5	77.0	1,9
TGL34-62	62 \pm 10%	55.8...68.8	50.2	5	89.0	1,7
TGL34-62A	62 \pm 5%	58.9...65.1	53.0	5	85.0	1,8
TGL34-68	68 \pm 10%	61.2...74.8	55.1	5	98.0	1,5
TGL34-68A	68 \pm 5%	64.6...71.4	58.1	5	92.0	1,6
TGL34-75	75 \pm 10%	67.5...82.5	60.7	5	108	1,4
TGL34-75A	75 \pm 5%	71.3...78.8	64.1	5	103	1,5
TGL34-82	82 \pm 10%	73.8...90.2	66.4	5	118	1,3
TGL34-82A	82 \pm 5%	77.9...86.1	70.1	5	113	1,3
TGL34-91	91 \pm 10%	81.9...100	73.7	5	131	1,1
TGL34-91A	91 \pm 5%	86.5...95.5	77.8	5	125	1,2
TGL34-100	100 \pm 10%	90.0...110	81.0	5	144	1,0
TGL34-100A	100 \pm 5%	95.0...105	85.5	5	137	1,1
TGL34-110	110 \pm 10%	99.0...121	89.2	5	158	0,9
TGL34-110A	110 \pm 5%	105...116	94.0	5	152	1,0
TGL34-120	120 \pm 10%	108...132	97.2	5	173	0,9
TGL34-120A	120 \pm 5%	114...126	102	5	165	0,9
TGL34-130	130 \pm 10%	117...143	105	5	187	0,8
TGL34-130A	130 \pm 5%	124...137	111	5	179	0,8
TGL34-150	150 \pm 10%	135...165	121	5	215	0,7
TGL34-150A	150 \pm 5%	143...158	128	5	207	0,7
TGL34-160	160 \pm 10%	144...176	130	5	230	0,7
TGL34-160A	160 \pm 5%	152...168	136	5	219	0,7
TGL34-170	170 \pm 10%	153...187	138	5	244	0,6
TGL34-170A	170 \pm 5%	162...179	145	5	234	0,6
TGL34-180	180 \pm 10%	162...198	146	5	258	0,6
TGL34-180A	180 \pm 5%	171...189	154	5	246	0,6
TGL34-200	200 \pm 10%	180...220	162	5	287	0,5
TGL34-200A	200 \pm 5%	190...210	171	5	274	0,5

For bidirectional types (suffix "C" or "CA") electrical characteristics apply in both directions
Für bidirektionale Dioden (Suffix "C" oder "CA") gelten die el. Werte in beiden Richtungen

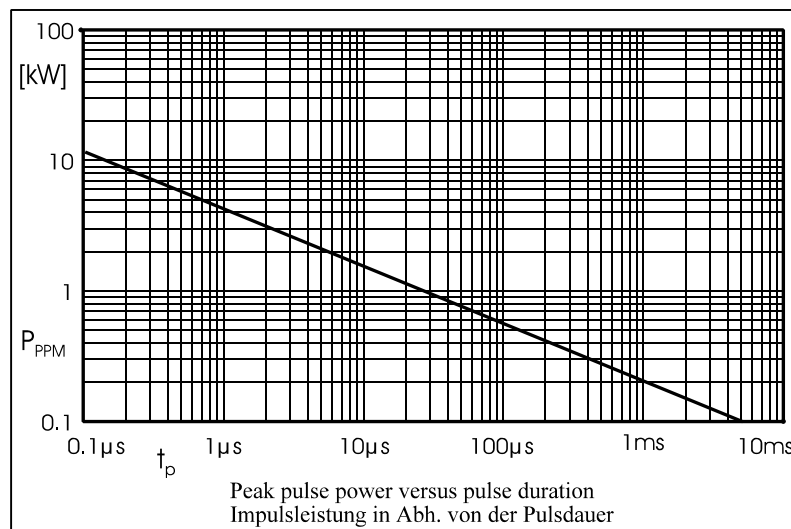
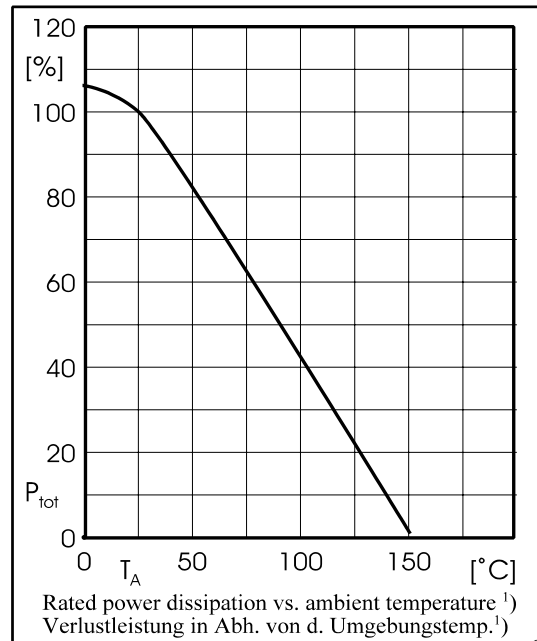
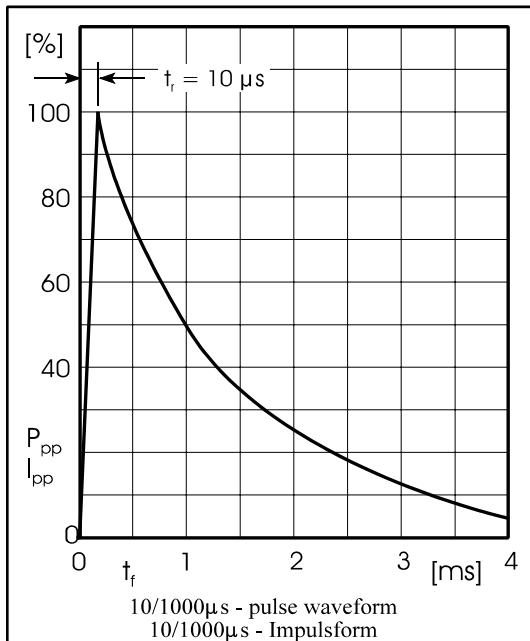

The order of type numbers is graded to the international E 24 standard. The standard tolerance of the breakdown voltage for each type is $\pm 10\%$. Suffix “A” denotes a tolerance of $\pm 5\%$ for the breakdown voltage.

e.g.: TGL 34-160CA = bidirectional diode, $V_{BR} = 160V (\pm 5\%)$, $V_{WM} = 136 V$
TGL 34-27A = unidirectional diode, $V_{BR} = 27V (\pm 5\%)$, $V_{WM} = 23.1 V$

Die Abstufung der Typen innerhalb der Reihe entspricht dem internationalen E 24-Standard. Die Toleranz der Arbeitsspannung jedes einzelnen Typs beträgt in der Standardausführung $\pm 10\%$. Suffix “A” kennzeichnet eine Toleranz der Arbeitsspannung von $\pm 5\%$.

z.B.: TGL 34-160CA = bidirektionale Diode, $V_{BR} = 160V (\pm 5\%)$, $V_{WM} = 136 V$
TGL 34-27A = unidirektionale Diode, $V_{BR} = 27V (\pm 5\%)$, $V_{WM} = 23.1 V$

¹⁾ Mounted on P.C. board with 25 mm² copper pads at each terminal
Montage auf Leiterplatte mit 25 mm² Kupferbelag (Lötpad) an jedem Anschluß