

IQXO-365, -366 Industrial Oscillator

ISSUE 6; 19 OCTOBER 1999

Delivery Options

- 3 day Express Manufacturing Service, subject to piece part stock availability.

Output Compatibility

- HCMOS/TTL
- Drive Capability: 50pF or 10 TTL
- Non tri-state (IQXO-365)
- Tri-state (IQXO-366)

Package Outline

- 14-pin DIL compatible resistance welded enclosure, hermetically sealed with glass to metal seals and high environmental performance.

Standard Frequency Stabilities

- ± 25 ppm, ± 50 ppm, ± 100 ppm (over the operating temperature range)

Frequency Tolerance at 25°C (Optional)

- ± 5 ppm, ± 10 ppm, ± 25 ppm

Operating Temperature Range

- 40 to 85°C

Storage Temperature Range

- 55 to 125°C

Environmental Specification

- Acceleration: 490m/s^2 for 1 minute in the 'Y₁' plane
- Bump: 4000 bumps at 390m/s^2 in each of the three mutually perpendicular planes
- Hermetic Seal: not to exceed 1×10^{-8} mBar litres of Helium leakage
- Humidity: steady state: in accordance with test Ca of IEC 68-2-3, for 56 days at 40°C at a relative humidity of 93%, cyclic: in accordance with test Db variant 1 of IEC 68-2-30, at severity b), 55 deg.C for six cycles
- Shock: 981m/s^2 for 6ms, three shocks in each direction along the three mutually perpendicular planes
- Solderability: BS2011 test TA
- Rapid Change of Temperature over Operating Temperature Range: 10 cycles
- Vibration: 10 to 60Hz 0.75mm displacement, 60 to 2000Hz 98.1m/s^2 acceleration, 30 minutes in each of three mutually perpendicular planes

Tri-state Operation (IQXO-366)

- Logic '0' to pin 1 disables oscillator output; when disabled the oscillator output goes to the high impedance state

- No connection or Logic '1' to pin 1 enables oscillator output
- Maximum 'pull-down' resistance required to disable output = 20k Ω
- Disable current 50 μ A typical

Marking

- Model number
- Frequency Stability Code
- Frequency Tolerance Code (Optional)
- Frequency
- Date code (Year/Week)

Minimum Order Information Required

- Frequency + Model Number + Frequency Stability

Outline in mm (inches)

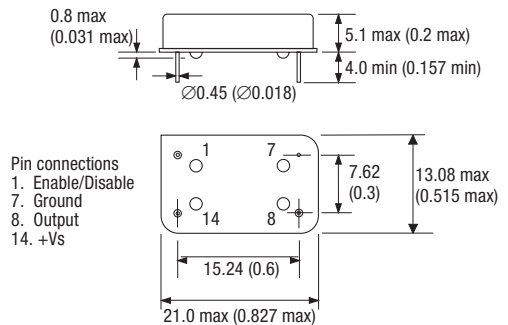

Note: Pin 1 = No connection on non tri-state models

Output Waveform - HCMOS/TTL

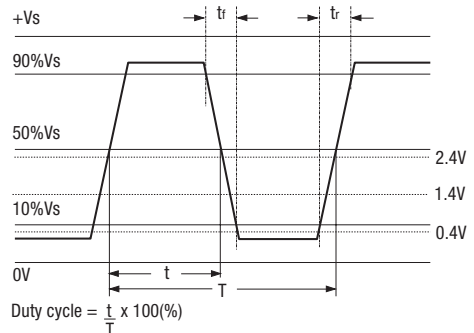

Electrical Specification – maximum limiting values when measured in HCMOS test circuit

Frequency Range	Frequency Stability	Supply Voltage	Supply Current	Rise Time (t _r)	Fall Time (t _f)	Duty Cycle	Model Number
500.0kHz to < 5.0MHz	±25ppm, ±50ppm, ±100ppm	5V±0.25V	20mA	15ns	15ns	45/55%	IQXO-365, -366
5.0 to < 16.0MHz	±25ppm, ±50ppm, ±100ppm	5V±0.25V	20mA	10ns	10ns	45/55%	IQXO-365, -366
16.0 to < 30.0MHz	±25ppm, ±50ppm, ±100ppm	5V±0.25V	30mA	10ns	10ns	45/55%	IQXO-365, -366
30.0 to < 50.0MHz	±25ppm, ±50ppm, ±100ppm	5V±0.25V	40mA	8ns	8ns	45/55%	IQXO-365, -366
50.0 to 70.0MHz	±25ppm, ±50ppm, ±100ppm	5V±0.25V	50mA	6ns	6ns	40/60%	IQXO-365, -366

Ordering Example

Frequency

Model No: -365 = Non tri-state, -366 = Tri-state

Frequency Stability: A = ±25ppm; B = ±50ppm; C = ±100ppm

Frequency Tolerance @ 25°C: D = ±5ppm; E = ±10ppm; F = ±25ppm

Please note: Code combination A F is not available

22.0MHz IQXO-365 B F

Test Circuit - HCMOS

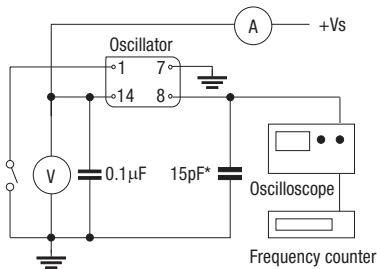

*Inclusive of jigging & equipment capacitance

Note: Pin 1 = No connection on non tri-state models

Test Circuit - TTL

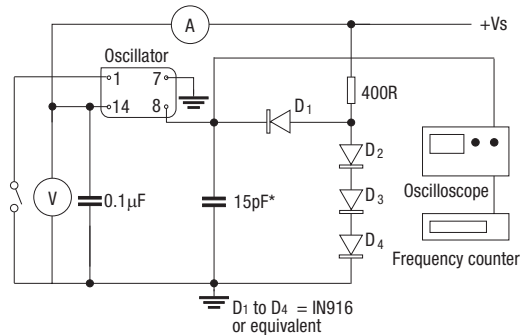

*Inclusive of jigging & equipment capacitance

Note: Pin 1 = No connection on non tri-state models