

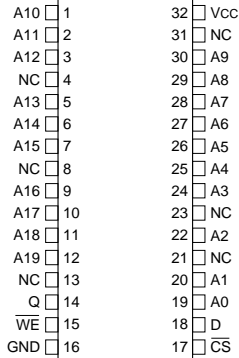

1Mx1 SRAM MONOLITHIC *ADVANCED**

PIN CONFIGURATION TOP VIEW



PIN DESCRIPTION

A0-19	Address Inputs
D,Q	Data Input, Data Output
CS	Chip Select
WE	Write Enable
Vcc	Power Supply
GND	Ground
NC	Not Connected

FEATURES

- Access Times 20, 25, 35ns
- MIL-STD-883 Compliant Devices Available
- Packaging
 - 32 lead, Ceramic SOJ (Package 101)
- Commercial, Industrial and Military Temperature Ranges
- Organized as 1M x 1
- 5 Volt Power Supply
- Low Power CMOS
- TTL Compatible Inputs and Outputs
- 2V Data Retention Devices also Available for Battery Back-Up Operation

* This data sheet describes a product that may or may not be under development and is subject to change or cancellation without notice.



ABSOLUTE MAXIMUM RATINGS

Parameter	Symbol	Min	Max	Unit
Operating Temperature	T _A	-55	+125	°C
Storage Temperature	T _{STG}	-65	+150	°C
Signal Voltage Relative to GND	V _G	-0.5	V _{CC} +0.5	V
Junction Temperature	T _J		150	°C
Supply Voltage	V _{CC}	-0.5	7.0	V

RECOMMENDED OPERATING CONDITIONS

Parameter	Symbol	Min	Max	Unit
Supply Voltage	V _{CC}	4.5	5.5	V
Input High Voltage	V _{IH}	2.2	V _{CC} + 0.3	V
Input Low Voltage	V _{IL}	-0.5	+0.8	V
Operating Temp. (Mil.)	T _A	-55	+125	°C

TRUTH TABLE

\overline{CS}	\overline{WE}	Mode	I/O Pin	Cycle	Current
H	X	Not Selected	High-Z	—	I _{SB1} , I _{SB2}
L	H	Read	D _{OUT}	Read	I _{CCA}
L	L	Write	High-Z	Write	I _{CCA}

H = High, L = Low, X = Don't Care

CAPACITANCE (T_A = +25°C)

Parameter	Symbol	Condition	Max	Unit
Input capacitance	C _{IN}	V _{IN} = 0V, f = 1.0MHz	15	pF
Output capacitance	C _{OUT}	V _{OUT} = 0V, f = 1.0MHz	15	pF

This parameter is guaranteed by design but not tested.

DC CHARACTERISTICS

(V_{CC} = 5.0V, GND = 0V, T_A = -55°C to +125°C)

Parameter	Sym	Conditions	Units		
			Min	Max	
Input Leakage Current	I _{LI}	V _{CC} = 5.5, V _{IN} = GND to V _{CC}		10	μA
Output Leakage Current	I _{LO}	$\overline{CS} = V_{IH}, \overline{OE} = V_{IH}, V_{OUT} = GND \text{ to } V_{CC}$		10	μA
Operating Supply Current	I _{CC}	$\overline{CS} = V_{IL}, \overline{OE} = V_{IH}, f = 5\text{MHz}, V_{CC} = 5.5$		105	mA
Standby Current	I _{SB}	$\overline{CS} = V_{IH}, \overline{OE} = V_{IH}, f = 5\text{MHz}$		30	mA
Output Low Voltage	V _{OL}	I _{OL} = 8mA, V _{CC} = 4.5		0.4	V
Output High Voltage	V _{OH}	I _{OH} = -4.0mA, V _{CC} = 4.5	2.4		V

NOTE: DC test conditions: V_{IH} = V_{CC} - 0.3V, V_{IL} = 0.3V

AC TEST CIRCUIT

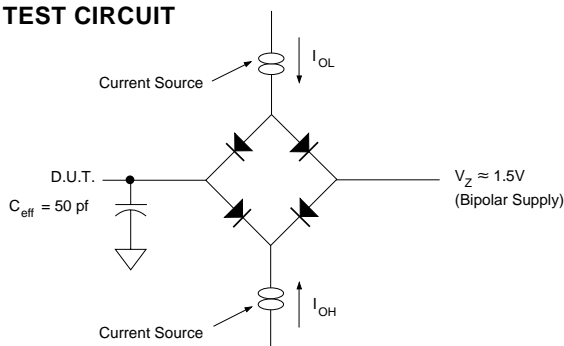

AC TEST CONDITIONS

Parameter	Typ	Unit
Input Pulse Levels	V _{IL} = 0, V _{IH} = 3.0	V
Input Rise and Fall	5	ns
Input and Output Reference Level	1.5	V
Output Timing Reference Level	1.5	V

NOTES:

V_Z is programmable from -2V to +7V.
I_{OL} & I_{OH} programmable from 0 to 16mA.
Tester Impedance Z₀ = 75 Ω.
V_Z is typically the midpoint of V_{OH} and V_{OL}.
I_{OL} & I_{OH} are adjusted to simulate a typical resistive load circuit.
ATE tester includes jig capacitance.

**AC CHARACTERISTICS**(V_{CC} = 5.0V, GND = 0V, T_A = -55°C to +125°C)

Parameter Read Cycle	Symbol	-20		-25		-35		Units
		Min	Max	Min	Max	Min	Max	
Read Cycle Time	t _{RC}	20		25		35		ns
Address Access Time	t _{AA}		20		25		35	ns
Output Hold from Address Change	t _{OH}	0		5		5		ns
Chip Select Access Time	t _{ACS}		20		25		35	ns
Chip Select to Output in Low Z	t _{CLZ} ¹	5		5		5		ns
Chip Disable to Output in High Z	t _{CHZ} ¹		9		10		12	ns

1. This parameter is guaranteed by design but not tested.

AC CHARACTERISTICS(V_{CC} = 5.0V, GND = 0V, T_A = -55°C to +125°C)

Parameter Write Cycle	Symbol	-20		-25		-35		Units
		Min	Max	Min	Max	Min	Max	
Write Cycle Time	t _{WC}	20		25		35		ns
Chip Select to End of Write	t _{CW}	15		20		25		ns
Address Valid to End of Write	t _{AW}	15		20		25		ns
Data Valid to End of Write	t _{DW}	12		15		20		ns
Write Pulse Width	t _{WP}	15		20		25		ns
Address Setup Time	t _{AS}	2		2		2		ns
Address Hold Time	t _{AH}	0		0		0		ns
Output Active from End of Write	t _{OW} ¹	5		5		5		ns
Write Enable to Output in High Z	t _{WHZ} ¹	0	9	0	10	0	12	ns
Data Hold Time	t _{DH}	0		0		0		ns

1. This parameter is guaranteed by design but not tested.



TIMING WAVEFORM - READ CYCLE

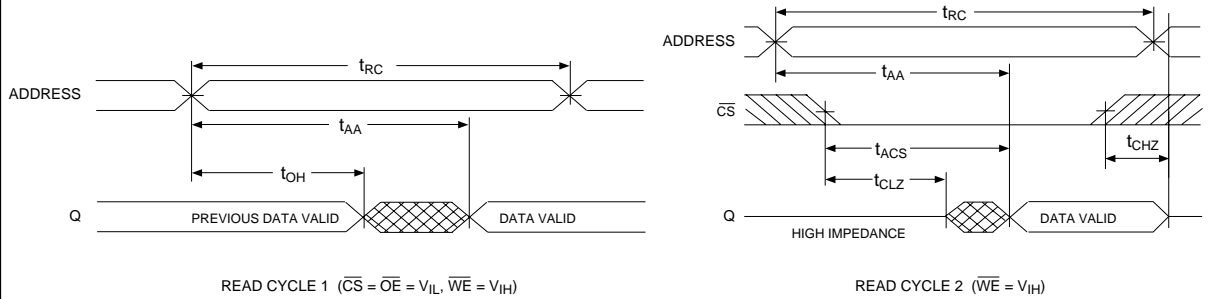

WRITE CYCLE - \overline{WE} CONTROLLED

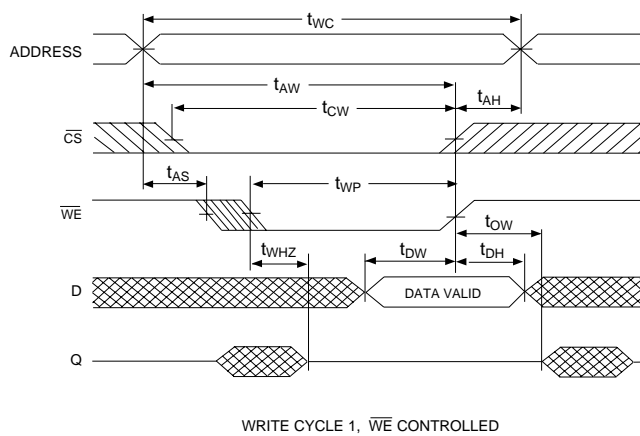

WRITE CYCLE - \overline{CS} CONTROLLED

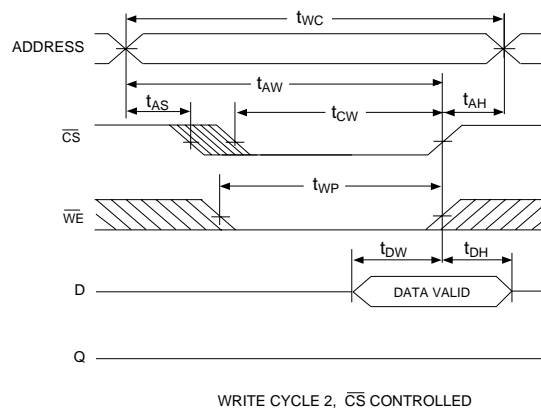



PACKAGE 101: 32 LEAD, CERAMIC SOJ

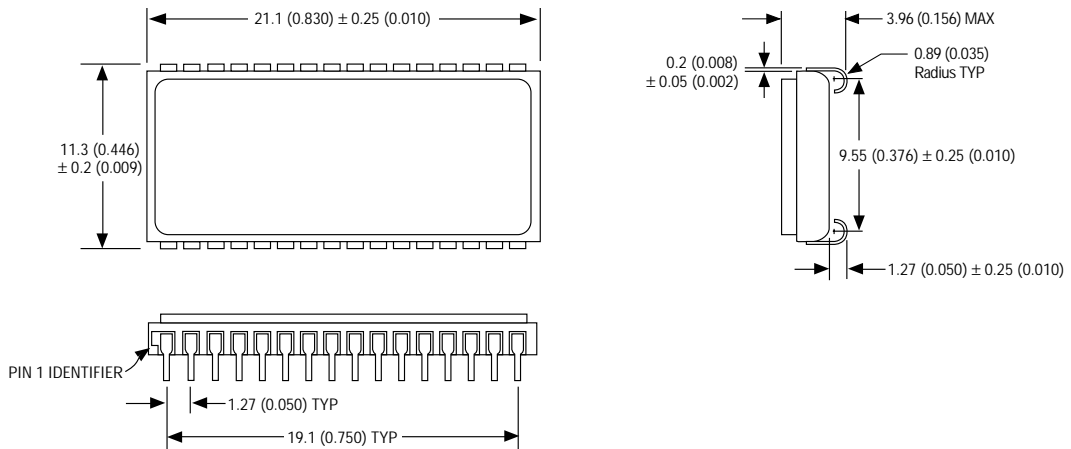

ALL LINEAR DIMENSIONS ARE MILLIMETERS AND PARENTHETICALLY IN INCHES

ORDERING INFORMATION

W M S 1 M 1 - X X X D E X X

