

Chip Coils



for Choke Winding Type LQH31C/LQH32C/LQH43C Series

LQH31C Series

■ Features

LQH31C series consists of miniature chip inductors with low DC resistance, high current capacity, and high impedance characteristics. It is suitable for use as choke coils in DC power supply circuits. High rated current up to 970mA is available.

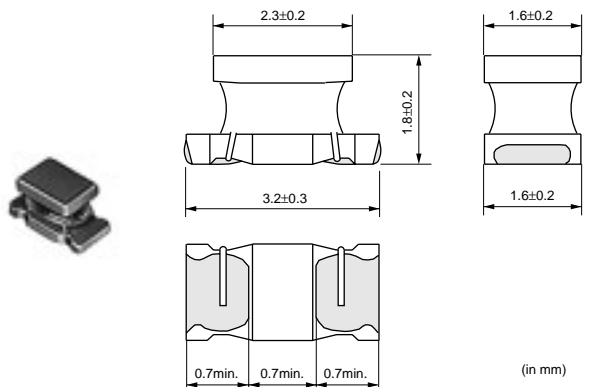

Part Number	Inductance (μH)	Test Frequency (MHz)	Rated Current (mA)	DC Resistance (ohm)	Self Resonance Frequency (min.) (MHz)	EIA
LQH31CNR12M03	0.12 ±20%	1	970	0.08 ±40%	250	1206
LQH31CNR22M03	0.22 ±20%	1	850	0.1 ±40%	250	1206
LQH31CNR47M03	0.47 ±20%	1	700	0.15 ±40%	180	1206
LQH31CN1R0M03	1.0 ±20%	1	510	0.28 ±30%	100	1206
LQH31CN2R2M03	2.2 ±20%	1	430	0.41 ±30%	50	1206
LQH31CN4R7M03	4.7 ±20%	1	340	0.65 ±30%	31	1206
LQH31CN100K03	10 ±10%	1	230	1.3 ±30%	20	1206
LQH31CN220K03	22 ±10%	1	160	3.0 ±30%	14	1206
LQH31CN470K03	47 ±10%	1	100	8.0 ±30%	10	1206
LQH31CN101K03	100 ±10%	1	80	12 ±30%	7	1206

Operating Temp. Range : -25°C to +85°C

■ Impedance-Frequency Characteristics

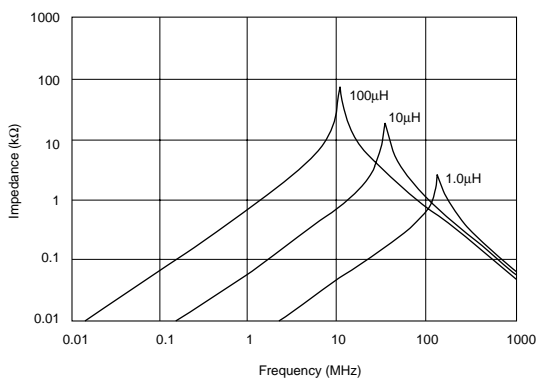

■ Inductance-Current Characteristics

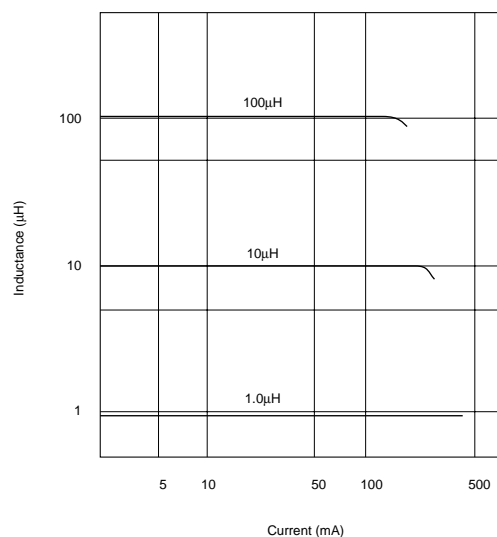

LQH32C series consists of miniature chip coils with low DC resistance, high current capacity, and high impedance characteristics. These features are made possible by the development of Murata's innovative automatic winding techniques.

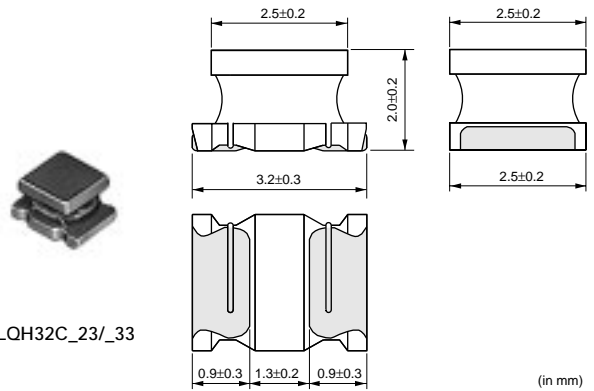

■ Features (LQH32C_23/_33)

1. Low DC resistance, high rated current and high inductance. Inductance : 0.15 to 560 micro H.
2. The series exhibits low voltage drops and small variations in inductance with respect to temperature rise and DC current level. This makes them excellent for use as power supply line choke coils.
3. The series has excellent solder heat resistance. Both flow and reflow soldering methods can be employed.

LQH32C_23 Series

Part Number	Inductance (μH)	Test Frequency	Rated Current (mA)	DC Resistance (ohm)	Self Resonance Frequency (min.) (MHz)	EIA
LQH32CN1R0M23	1.0 ±20%	1MHz	800	0.09 ±30%	96	1210
LQH32CN2R2M23	2.2 ±20%	1MHz	600	0.13 ±30%	64	1210
LQH32CN4R7M23	4.7 ±20%	1MHz	450	0.2 ±30%	43	1210
LQH32CN100K23	10 ±10%	1MHz	300	0.44 ±30%	26	1210
LQH32CN220K23	22 ±10%	1MHz	250	0.71 ±30%	19	1210
LQH32CN470K23	47 ±10%	1MHz	170	1.3 ±30%	15	1210
LQH32CN101K23	100 ±10%	1MHz	100	3.5 ±30%	10	1210
LQH32CN221K23	220 ±10%	1MHz	70	8.4 ±30%	6.8	1210
LQH32CN331K23	330 ±10%	1MHz	60	10 ±30%	5.6	1210
LQH32CN391K23	390 ±10%	1MHz	60	17 ±30%	5	1210
LQH32CN471K23	470 ±10%	1kHz	60	19 ±30%	5	1210
LQH32CN561K23	560 ±10%	1kHz	60	22 ±30%	5	1210

Operating Temp. Range : -25°C to +85°C

LQH32C_33 Series (Low DC Resistance Type)

Part Number	Inductance (μH)	Test Frequency (MHz)	Rated Current (mA)	DC Resistance (ohm)	Self Resonance Frequency (min.) (MHz)	EIA
LQH32CNR15M33	0.15 ±20%	1	1450	0.028 ±30%	400	1210
LQH32CNR27M33	0.27 ±20%	1	1250	0.034 ±30%	250	1210
LQH32CNR47M33	0.47 ±20%	1	1100	0.042 ±30%	150	1210
LQH32CN1R0M33	1.0 ±20%	1	1000	0.06 ±30%	100	1210
LQH32CN2R2M33	2.2 ±20%	1	790	0.097 ±30%	64	1210
LQH32CN4R7M33	4.7 ±20%	1	650	0.15 ±30%	43	1210
LQH32CN100K33	10 ±10%	1	450	0.3 ±30%	26	1210

Operating Temp. Range : -25°C to +85°C

■ Impedance-Frequency Characteristics

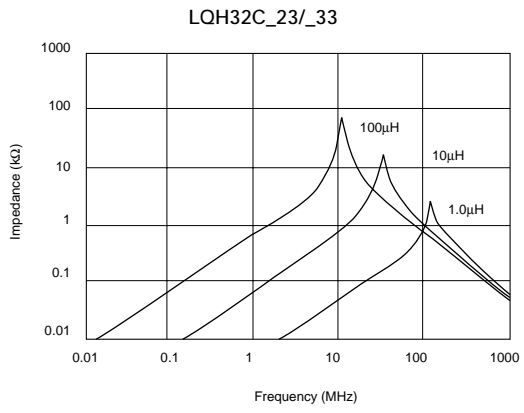

■ Inductance-Current Characteristics

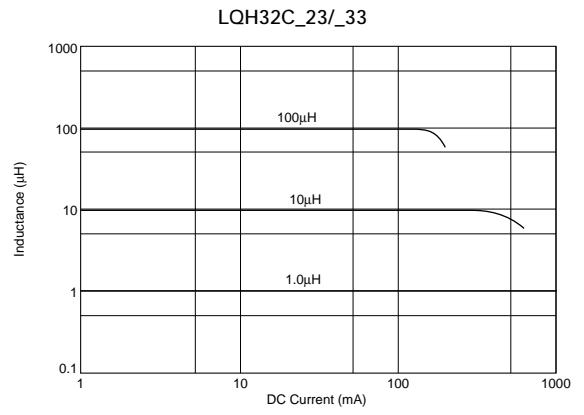

LQH32C_53 Series (Low Profile Type)

LQH32C_53 series consists of miniature chip coils with low DC resistance, high current capacity, and high impedance characteristics. These features are made possible by the development of Murata's innovative winding techniques. They are excellent for use as choke coils in DC power supply circuits. The LQH32C_53 series has achieved Max 1.7mm height and high rated current.

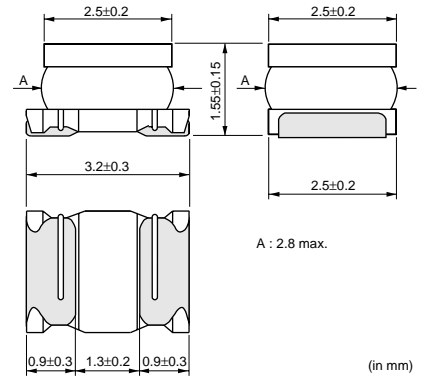

■ Features

1. The series has a wide inductance range of 1.0 to 100 micro H.
2. The series exhibit low voltage drops and small variations in inductance with respect to temperature rise and DC current level. This makes them excellent for use as power supply line choke coils.
3. The series has excellent solder heat resistance. Both flow and reflow soldering methods can be employed.

Part Number	Inductance (μH)	Test Frequency (MHz)	Rated Current (mA)	DC Resistance (ohm)	Self Resonance Frequency (min.) (MHz)	EIA
LQH32CN1R0M53	1.0 ±20%	1	1000	0.060 ±30%	100	1210
LQH32CN2R2M53	2.2 ±20%	1	790	0.097 ±30%	64	1210
LQH32CN4R7M53	4.7 ±20%	1	650	0.15 ±30%	43	1210
LQH32CN100K53	10 ±10%	1	450	0.30 ±30%	26	1210
LQH32CN150K53	15 ±10%	1	300	0.58 ±30%	26	1210
LQH32CN220K53	22 ±10%	1	250	0.71 ±30%	19	1210
LQH32CN330K53	33 ±10%	1	200	1.1 ±30%	17	1210
LQH32CN470K53	47 ±10%	1	170	1.3 ±30%	15	1210
LQH32CN680K53	68 ±10%	1	130	2.2 ±30%	12	1210
LQH32CN101K53	100 ±10%	1	100	3.5 ±30%	10	1210

Operating Temp. Range : -25°C to +85°C

■ Impedance-Frequency Characteristics

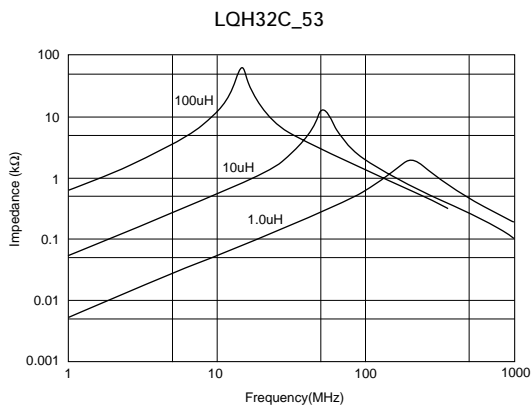

■ Inductance-Current Characteristics

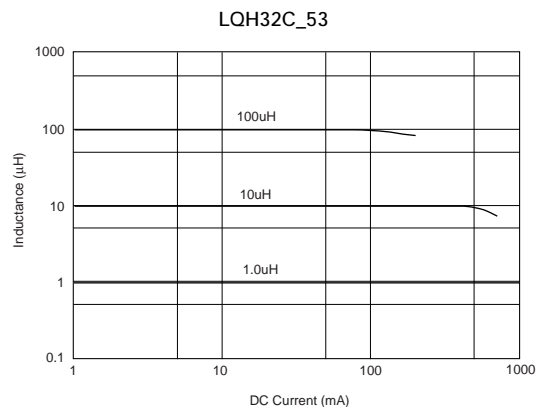

LQH43C Series

LQH43C series consists of miniature chip inductors with low DC resistance, high current capacity, and high impedance characteristics. It is suitable for use as choke coils in DC power supply circuits.

■ Features

1. Various inductance ranges are available.
2. The series exhibits low voltage drops and small change in inductance with respect to temperature rise and DC current level. This makes them excellent to use as power supply line choke coils.
3. Small size 4.5x3.2mm and realized low height 2.8mm max.
4. The series has excellent solder heat resistance. Both flow and reflow soldering methods can be employed.

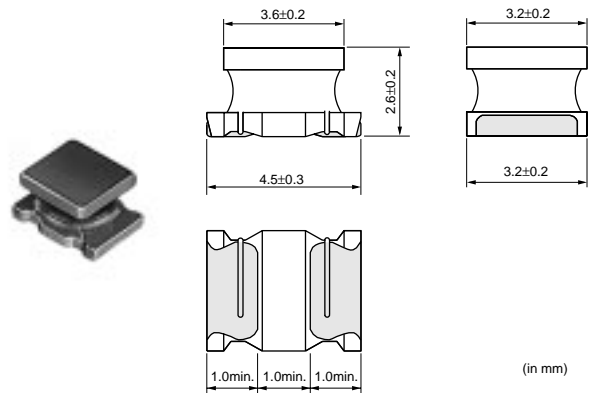

Part Number	Inductance (μH)	Test Frequency	Rated Current (mA)	DC Resistance (ohm)	Self Resonance Frequency (min.) (MHz)	EIA
LQH43CN1R0M03	1.0 ±20%	1MHz	1080	0.08 max.	100	1812
LQH43CN1R5M03	1.5 ±20%	1MHz	1000	0.09 max.	85	1812
LQH43CN2R2M03	2.2 ±20%	1MHz	900	0.11 max.	60	1812
LQH43CN3R3M03	3.3 ±20%	1MHz	800	0.13 max.	47	1812
LQH43CN4R7M03	4.7 ±20%	1MHz	750	0.15 max.	35	1812
LQH43CN6R8M03	6.8 ±20%	1MHz	720	0.20 max.	30	1812
LQH43CN100K03	10 ±10%	1MHz	650	0.24 max.	23	1812
LQH43CN150K03	15 ±10%	1MHz	570	0.32 max.	20	1812
LQH43CN220K03	22 ±10%	1MHz	420	0.6 max.	15	1812
LQH43CN330K03	33 ±10%	1MHz	310	1.0 max.	12	1812
LQH43CN470K03	47 ±10%	1MHz	280	1.1 max.	10	1812
LQH43CN680K03	68 ±10%	1MHz	220	1.7 max.	8.4	1812
LQH43CN101K03	100 ±10%	1MHz	190	2.2 max.	6.8	1812
LQH43CN151K03	150 ±10%	1MHz	130	3.5 max.	5.5	1812
LQH43CN221K03	220 ±10%	1MHz	110	4.0 max.	4.5	1812
LQH43CN331K03	330 ±10%	1MHz	100	6.8 max.	3.6	1812
LQH43CN471K03	470 ±10%	1kHz	90	8.5 max.	3.0	1812

Operating Temp. Range : -25°C to +85°C

■ Impedance-Frequency Characteristics

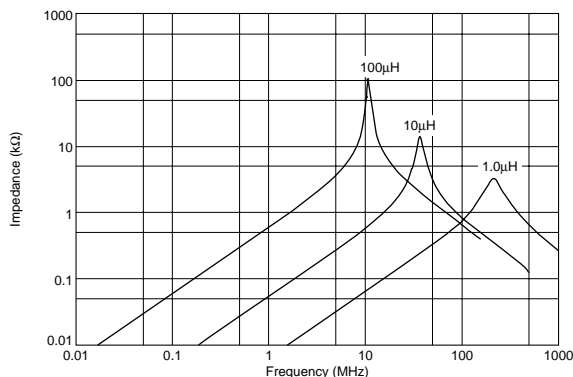

■ Inductance-Current Characteristics

