

64M-Bit (4Mx16) CMOS MASK ROM

FEATURES

- 4,194,304 x 16 bit organization
- Fast access time : 100ns(Max.)
- Supply voltage : single +5V
- Current consumption
Operating : 70mA(Max.)
- Fully static operation
- All inputs and outputs TTL compatible
- Three state outputs
- Package
-. KM23C64000B : 42-DIP-600

GENERAL DESCRIPTION

The KM23C64000B is a fully static mask programmable ROM organized 4,194,304 x 16 bit. It is fabricated using silicon-gate CMOS process technology.

This device operates with a 5V single power supply, and all inputs and outputs are TTL compatible.

Because of its asynchronous operation, it requires no external clock assuring extremely easy operation.

It is suitable for use in program memory of microprocessor and data memory, character generator.

The KM23C64000B is packaged in a 42-DIP.

FUNCTIONAL BLOCK DIAGRAM

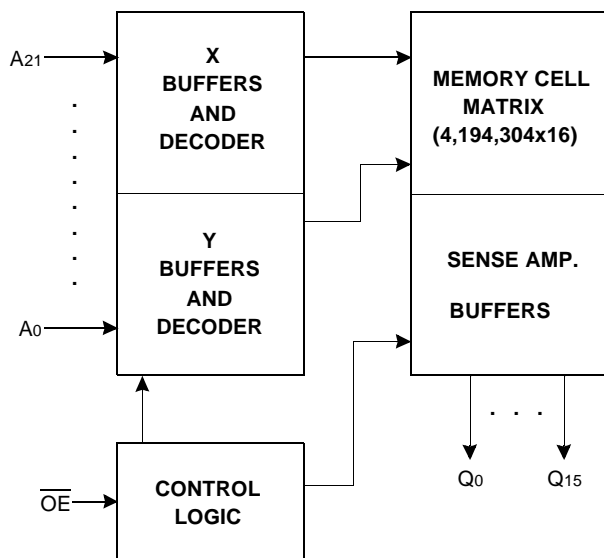

Pin Name	Pin Function
A ₀ - A ₂₁	Address Inputs
Q ₀ - Q ₁₅	Data Outputs
\overline{OE}	Output Enable
V _{cc}	Power (+5V)
V _{ss}	Ground

PIN CONFIGURATION

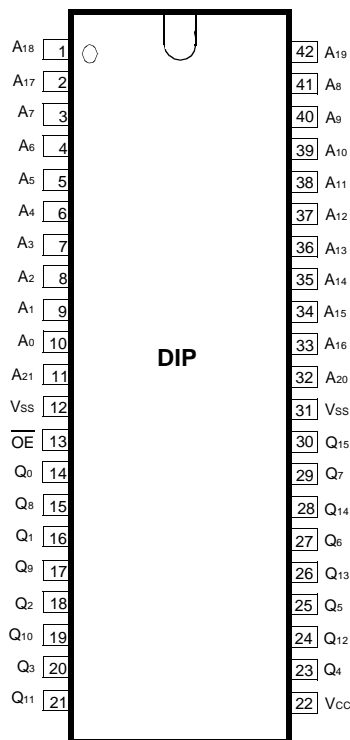

KM23C64000B

ABSOLUTE MAXIMUM RATINGS

Item	Symbol	Rating	Unit
Voltage on Any Pin Relative to Vss	V _{IN}	-0.3 to +7.0	V
Temperature Under Bias	T _{BIAS}	-10 to +85	°C
Storage Temperature	T _{STG}	-55 to +150	°C

NOTE : Permanent device damage may occur if "ABSOLUTE MAXIMUM RATINGS" are exceeded. Functional operation should be restricted to the conditions as detailed in the operational sections of this data sheet. Exposure to absolute maximum rating conditions for extended periods may affect device reliability.

RECOMMENDED OPERATING CONDITIONS(Voltage reference to V_{ss}, T_A=0 to 70°C)

Item	Symbol	Min	Typ	Max	Unit
Supply Voltage	V _{CC}	4.5	5.0	5.5	V
Supply Voltage	V _{SS}	0	0	0	V

DC CHARACTERISTICS

Parameter	Symbol	Test Conditions	Min	Max	Unit
Operating Current	I _{CC}	$\overline{OE}=V_{IL}$, all outputs open	-	70	mA
Input Leakage Current	I _{LI}	V _{IN} =0 to V _{CC}	-	10	μA
Output Leakage Current	I _{LO}	V _{OUT} =0 to V _{CC}	-	10	μA
Input High Voltage, All Inputs	V _{IH}		2.2	V _{CC} +0.3	V
Input Low Voltage, All Inputs	V _{IL}		-0.3	0.8	V
Output High Voltage Level	V _{OH}	I _{OH} =-400μA	2.4	-	V
Output Low Voltage Level	V _{OL}	I _{OL} =2.1mA	-	0.4	V

NOTE : Minimum DC Voltage(V_{IL}) is -0.3V an input pins. During transitions, this level may undershoot to -2.0V for periods <20ns.
Maximum DC voltage on input pins(V_{IH}) is V_{CC}+0.3V which, during transitions, may overshoot to V_{CC}+2.0V for periods <20ns.

MODE SELECTION

OE	Mode	Data	Power
H	Operating	High-Z	Active
L	Operating	Dout	Active

CAPACITANCE(T_A=25°C, f=1.0MHz)

Item	Symbol	Test Conditions	Min	Max	Unit
Output Capacitance	C _{OUT}	V _{OUT} =0V	-	12	pF
Input Capacitance	C _{IN}	V _{IN} =0V	-	12	pF

NOTE : Capacitance is periodically sampled and not 100% tested.

AC CHARACTERISTICS (TA=0°C to +70°C, VCC=5V±10%, unless otherwise noted.)

TEST CONDITIONS

Item	Value
Input Pulse Levels	0.6V to 2.4V
Input Rise and Fall Times	10ns
Input and Output timing Levels	0.8V and 2.0V
Output Loads	1 TTL Gate and CL=100pF

READ CYCLE

Item	Symbol	KM23C64000B-10		KM23C64000B-12		Unit
		Min	Max	Min	Max	
Read Cycle Time	tRC	100		120		ns
Address Access Time	tAA		100		120	ns
Output Enable Access Time	tOE		50		60	ns
Output Disable to Output High-Z	tDF		20		20	ns
Output Hold from Address Change	tOH	0		0		ns

TIMING DIAGRAM

READ

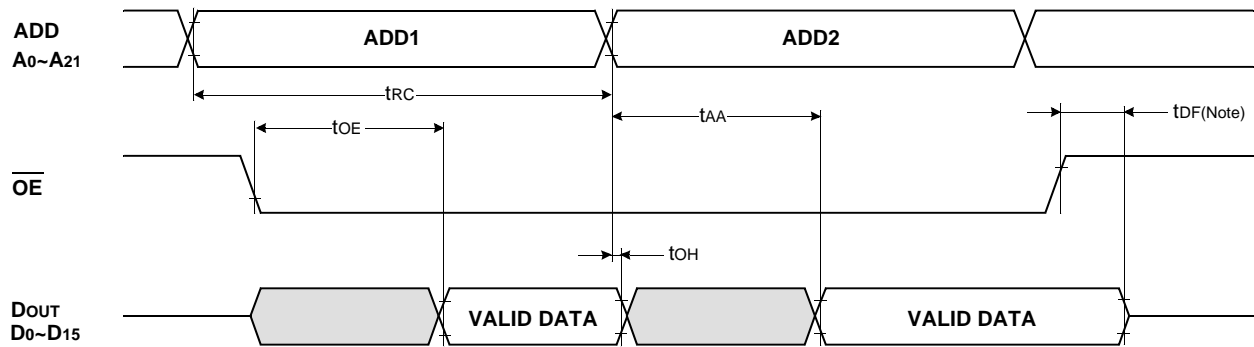

NOTE : tDF is defined as the time at which the outputs achieve the open circuit condition and is not referenced to VOH or VOL level.

PACKAGE DIMENSIONS

(Unit : mm/inch)

