

EC13 Series

- HCMOS/TTL output
- 3.3V supply voltage
- 8 pin DIP package
- Stability to 20ppm
- Custom lead length, gull wing options available

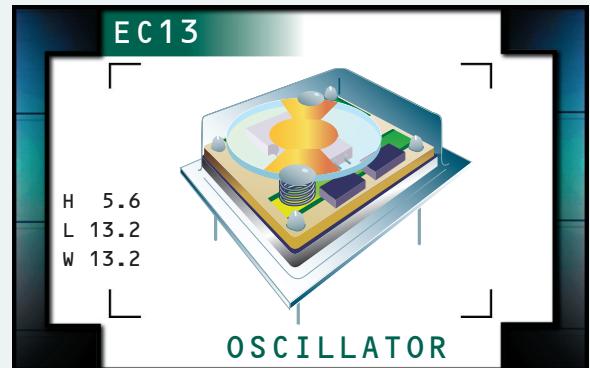

ELECTRICAL SPECIFICATIONS

Frequency Range	500.000kHz to 106.250MHz	
Operating Temperature Range	0°C to 70°C, -40°C to 85°C	
Storage Temperature Range	-55°C to 125°C	
Supply Voltage (V_{DD})	3.3V _{DC} ±0.3V _{DC}	
Input Current	500.000kHz to 24.000MHz	10mA Maximum
	24.001MHz to 70.000MHz	25mA Maximum
	70.001MHz to 106.250MHz	45mA Maximum
Frequency Tolerance / Stability	Inclusive of Operating Temperature Range, Supply Voltage, and Load	±100ppm, ±50ppm, ±25ppm, or ±20ppm Maximum (0°C to 70°C Only)
Output Voltage Logic High (V_{OH})	w/ TTL Load	2.4V _{DC} Minimum
	w/ HCMOS Load	2.7V _{DC} Minimum
Output Voltage Logic Low (V_{OL})	w/ TTL Load	0.4V _{DC} Maximum
	w/ HCMOS Load	0.5V _{DC} Maximum
Rise Time / Fall Time	10% to 90% of Waveform w/HCMOS Load	10 nSeconds Max. ≤24.000MHz 6 nSeconds Max. 24.001MHz to 70.000MHz 4 nSeconds Max. 70.000MHz to 106.250MHz
	0.4V _{DC} to 2.4V _{DC} w/TTL Load	10 nSeconds Max. ≤24.000MHz
Duty Cycle	at 50% of Waveform ≤70.000MHz	50 ±10(%) (Standard) or 50 ±5(%) (Optional)
	at 50% of Waveform 70.001MHz to 106.25MHz (0°C to 70°C)	50 ±10(%) (Standard) or 50 ±5(%) (Optional)
	at 50% of Waveform 70.001MHz to 106.25MHz (-40°C to 85°C)	50 ±10(%) (Standard)
Load Drive Capability	4.000MHz to 24.000MHz	2TTL or 15pF HCMOS Load
	24.001MHz to 106.250MHz	15pF HCMOS Load
Pin 1 Tri-State Input Voltage	V _{IH} :No Connection	Enables Output
	V _{IH} :≥2.2V _{DC}	Enables Output
	V _{IL} :≤0.8V _{DC}	Disables Output: High Impedance
Aging (at 25°C)	±5ppm / year Maximum	
Start Up Time	10 mSeconds Maximum	
Period Jitter: Absolute	±100pSeconds Maximum	
Period Jitter: One Sigma	±25pSeconds Maximum	

PART NUMBERING GUIDE

EC13 00 HS ET TS - 50.000M - G TR

FREQUENCY TOLERANCE / STABILITY

00=±100ppm Maximum (Standard)
 45=±50ppm Maximum, 25=±25ppm Maximum
 20=±20ppm Maximum

PACKAGE

HS=Half Size 8 Pin DIP

OPERATING TEMP. RANGE

Blank=0°C to 70°C (Standard), ET=-40°C to 85°C

DUTY CYCLE

Blank=50 ±10(%) (Standard), T=50 ±5(%)

PACKAGING OPTIONS

TR= Tape & Reel (only offered with Half Size G and Half Size G2 Options)

AVAILABLE OPTIONS

Blank=None (Standard)
 CLXX=Custom Lead Length (See Page 133)
 G=Half Size Gull Wing (See Page 132)
 G2=Half Size Gull Wing (See Page 132)

FREQUENCY

PIN 1 CONNECTION

Blank=No Connection (Standard)
 TS=Tri-State Enable High

MECHANICAL DIMENSIONS ALL DIMENSIONS IN MILLIMETERS

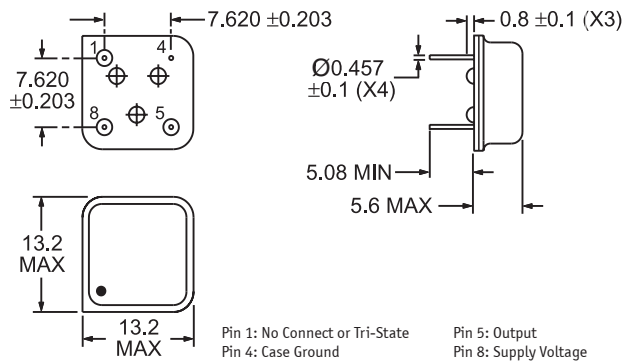

TAPE AND REEL DIMENSIONS ALL DIMENSIONS IN MILLIMETERS

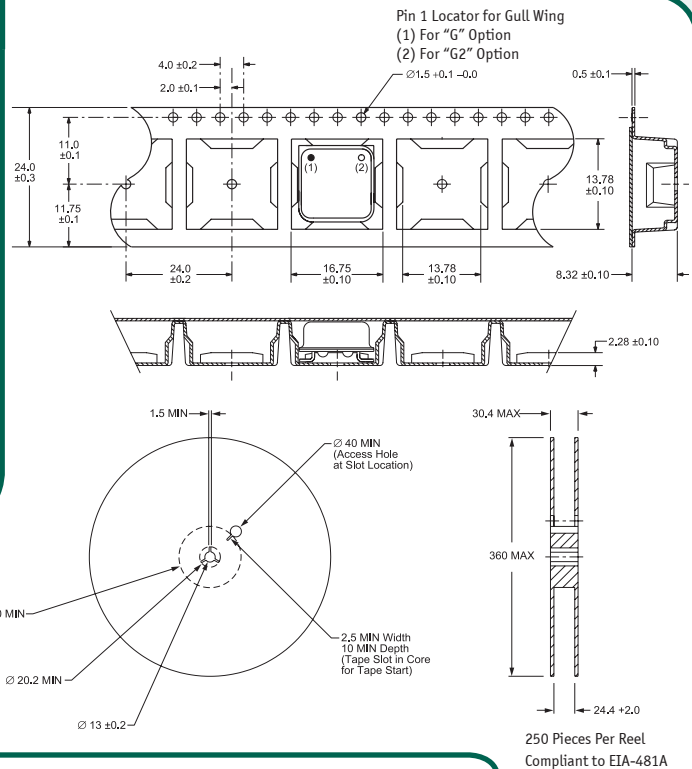

MARKING SPECIFICATIONS

- Line 1: ECLIPTEK
- Line 2: EC13 TS
 - Pin 1 Connection
 - Blank = No Connection
 - TS = Tri-State Enable High
 - Series Designator
- Line 3: XX.XXX M
 - Frequency in MHz
 - (5 Digits Maximum + Decimal)
- Line 4: XX Y ZZ
 - Week of Year
 - Last Digit of Year
 - Ecliptek Manufacturing Identifier

Note: Pin 1 shall be designated with a dot

ENVIRONMENTAL/MECHANICAL SPECIFICATIONS

Characteristic	Specification
Seal Integrity	Bubble test in Perfluorocarbon at +125°C ±5°C for 60 seconds minimum.
Solderability	Sn63 Solder dip at +230°C ±5°C for 5 seconds/95% coverage.
Marking Permanency	10 Strokes with brush after 1 minute soak in solvent, 3 times.
Shock	Random drop on hard wooden plate 3 times from a height of 20cm.
Vibration	Frequency with an amplitude of 1.5mm sweeping between 10Hz to 55Hz within 1 minute (approximately) for 2 hours minimum on each axis (X, Y and Z) for a total of 6 hours.

250 Pieces Per Reel
Compliant to EIA-481A

MANUFACTURER ECLIPTEK CORP.	CATEGORY OSCILLATOR	SERIES EC13	PACKAGE 8 pin DIP	VOLTAGE 3.3V	CLASS OS21	REV - DATE 10/01
--------------------------------	------------------------	----------------	----------------------	-----------------	---------------	---------------------