

## Precision Linear Transducers, Designed for Mounting in Hydraulic or Pneumatic Cylinder, Conductive Plastic Element (REC)

**FEATURES**

- Large Range of Strokes from 25 to 2000 mm
- High Accuracy
- Very Good Repeatability
- Continuous Resolution
- Easy Mounting

These unsealed sensors are suitable for installation in the high pressure chamber of cylinders.

<b>ELECTRICAL SPECIFICATIONS</b>	
Theoretical electrical travel (TET = E)	from 25mm to 2000mm in increments of 25mm
Independent linearity over TET on request	$\leq \pm 1\%$ ; $\leq \pm 0.1\%$ $\leq \pm 0.05\%$ if $E \geq 100\text{mm}$ , $\leq \pm 0.025\%$ if $E \geq 200\text{mm}$
Actual electrical travel (AET)	TET + 6mm $\pm$ 0.5
Total resistance $R_T$	150 $\Omega$ /cm
Resistance tolerance at 20°C	$\pm 20\%$
Repeatability	$\leq 0.01\%$
Maximum power rating	0.05W/cm at 70°C, 0W at 125°C
Wiper current	1mA max. continuous, recommended: a few $\mu$ A
Load impedance	1000 times $R_T$ minimum
Insulation resistance	> 1000M $\Omega$ 500VDC
Dielectric strength	> 300VRMS at 50Hz

<b>MECHANICAL SPECIFICATIONS</b>	
Mechanical travel MT	MT = TET
Body	anodized aluminum
Rod internal diameter	14 LH : $\varnothing$ 16mm, 16 LH : $\varnothing$ 18mm
Support	2 screws
Operating force	1N typical
Electrical outputs	wires 300mm long
Oil	insulating mineral hydraulic
Pressure	300 bars continuous, 1000 bars accidentally
Wiper	precious metal multifinger

<b>PERFORMANCE</b>	
Life	40 million of cycles
Temperature limits	- 20°C to + 80°C
Speed at 20°C	1.5m/s max.

# 14 LH, 16 LH



Vishay Sfernice

Precision Linear Transducers  
 Designed for Mounting in Hydraulic or Pneumatic Cylinder,  
 Conductive Plastic Element (REC)

## DIMENSIONS in millimeters, general tolerance $\pm 1$ mm

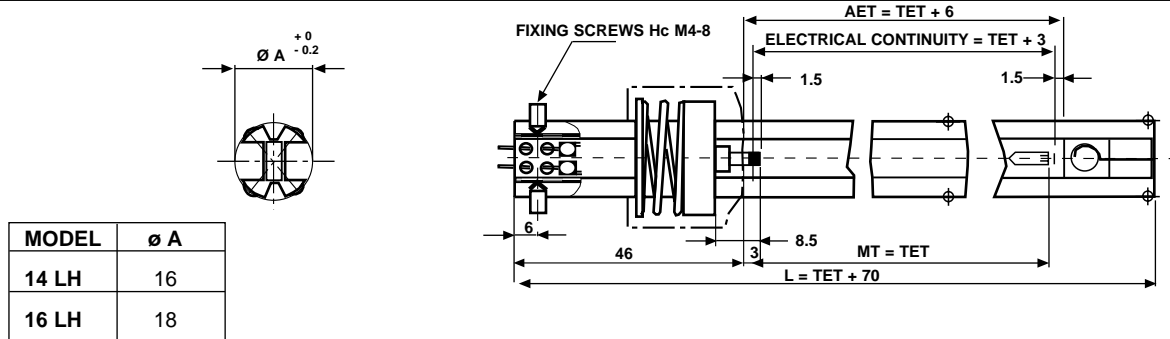

MODEL	$\varnothing A$
14 LH	16
16 LH	18

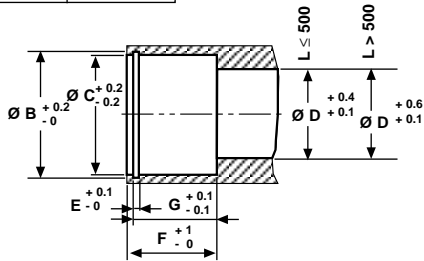

	B	C	D	E	F	G
14 LH	23	22	16	1.1	15.3	13.8
16 LH	25.2	24	18	1.3	17.8	16.3

## MOUNTING IN ACTUATOR

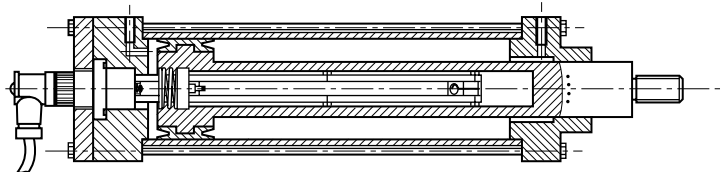

On these models:  
 Cylinder sealing and electrical connections required

## ELECTRICAL CONNECTIONS

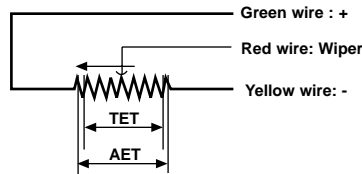

TET = Theoretical electrical travel  
 AET = Actual electrical travel

## ORDERING INFORMATION

REC	14	LH	4	D	152	W...
SERIES	MODEL	TYPE	THEORETICAL ELECTRICAL TRAVEL	LINEARITY	RESISTANCE	MODIFICATIONS
		Unsealed	Times 25mm	A: $\leq \pm 1\%$ D: $\leq \pm 0.1\%$ E: $\leq \pm 0.05\%$ F: $\leq \pm 0.025\%$	First 2 digits are significant numbers Third indicates number of zeros	Special Feature Code Number