

# Precision Linear Transducers, Conductive Plastic (REC)



## FEATURES

- Large Measurement Range
- High Accuracy  $\pm 1\%$  down to  $\pm 0.025\%$
- Long Life
- Essentially Infinite Resolution
- Easy mounting

The 110 L is a compact, robust, easily mounted precision industrial motion transducer.

<b>ELECTRICAL SPECIFICATIONS</b>	
Theoretical electrical travel (TET)	25mm to 450mm in increments of 25mm
Independent linearity (over TET) on request	$\leq \pm 1\% \leq \pm 0.1\%$ $\leq \pm 0.05\%$ for $E \geq 100\text{mm}$ $\leq \pm 0.025\%$ for $E \geq 200\text{mm}$
Actual electrical travel (AET)	See Electrical Connections Table 1
Repeatability	$\leq \pm 0.01\%$
Ohmic values (R <sub>T</sub> )	400Ω/cm to 2kΩ/cm
Resistance tolerance at 20°C	$\pm 20\%$
Maximum power rating	0.05W/cm at 70°C    0W at 125°C
Wiper current	recommended: a few μA - 1mA max. continuous
Load resistance	minimum $10^3 \times R_T$
Insulation resistance	$\geq 1000\text{M}\Omega$ 500VDC
Dielectric strength	$\geq 750\text{VRMS}$ 50Hz

<b>MECHANICAL SPECIFICATIONS</b>	
Mechanical travel	TET + 6mm min
Housing	anodized aluminum
Operating force	5N typical
Shaft (free rotation)	stainless steel
Termination on request	connector by cable
Wiper	precious metal multifinger
Mounting	movable brackets

<b>PERFORMANCE</b>	
Operating life	40 million cycles typical
Temperature range	- 55°C + 125°C
Mechanical shocks on 3 axes	50g - 11ms - half sine
Sine vibrations on 3 axes	1.5mm peak to peak or 15g - 10Hz - 2000Hz

**DIMENSIONS** in millimeters, general tolerance  $\pm 1$ mm

**STANDARD MODEL**

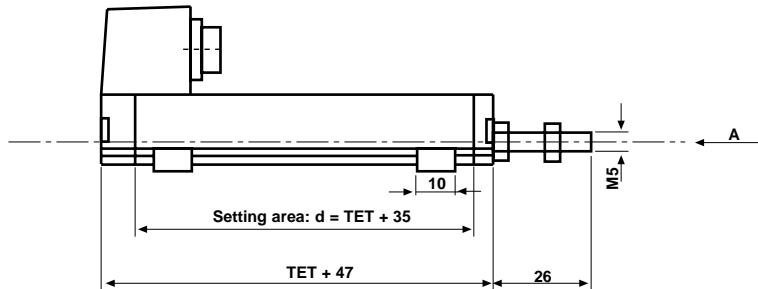
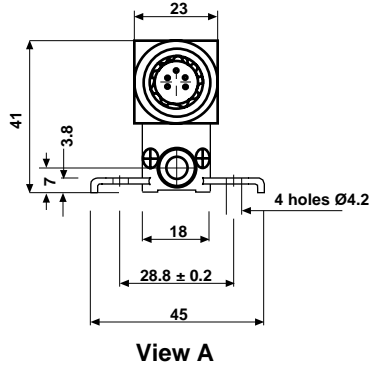

**WITH CABLE OUTPUT: W04029**

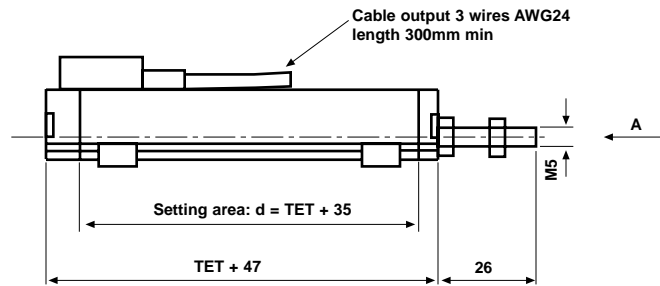
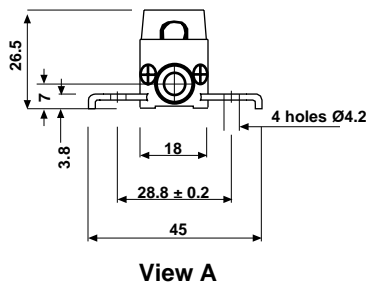

**ELECTRICAL CONNECTIONS**

**STD AND W04030**

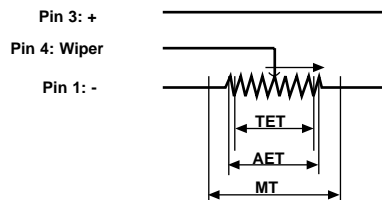

**W04029 AND W04031**

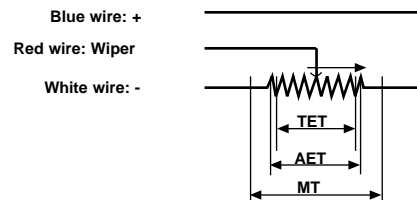

TET = Theoretical electrical travel  
 AET = Actual electrical travel  
 MT = Mechanical travel

Table 1

THEORETICAL ELECTRICAL TRAVEL TET	ACTUAL ELECTRICAL TRAVEL AET	TOLERANCE
from 25mm to 275mm	TET + 1 mm	$\pm 0.5$ mm
from 300mm to 450mm	TET + 1 mm	$\pm 0.8$ mm

**OPTION: SPRING LOADED SHAFT DIMENSIONS** in millimeters, general tolerance  $\pm 1$  mm

**110L WITH SPRING LOADED SHAFT: W04030**

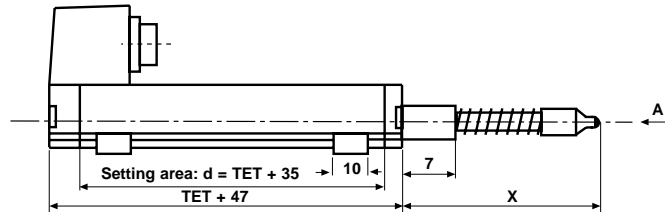
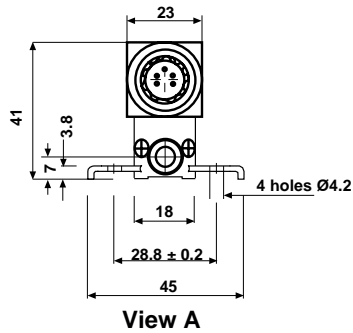
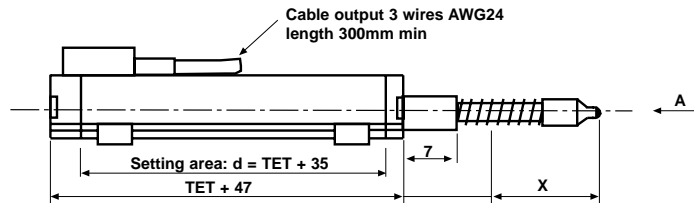
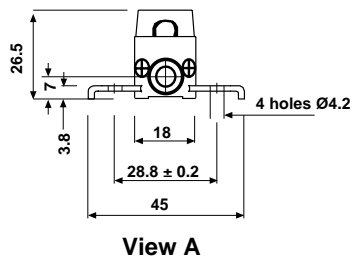

Table 2

MODEL	X
110 L1	75
110 L2	112
110 L3	150
110 L4	188

**110L WITH CABLE OUTPUT AND SPRING LOADED SHAFT: W04031**



**ACCESSORIES ON REQUEST DIMENSIONS** in millimeters, general tolerance  $\pm 1$ mm

**1) FEMALE CONNECTOR**  
Vishay's Reference: 328870

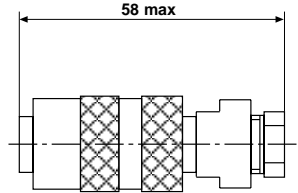

**2) SPECIAL BALL JOINT**  
Vishay's reference: 323654

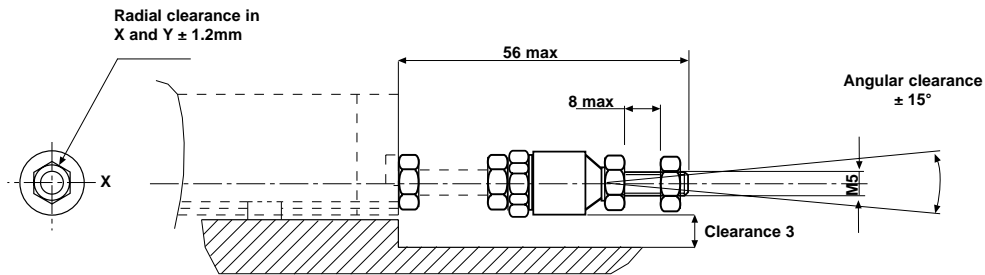

**ORDERING INFORMATION**

REC	110	L	3	D	103	W...
SERIES	MODEL	NUMBER OF TRACKS	THEORETICAL ELECTRICAL TRAVEL	LINEARITY	OHMIC VALUE	MODIFICATIONS
		L = 1 track	Times 25 mm	A : $\pm 1\%$ D : $\pm 0.1\%$ E : $\pm 0.05\%$ F : $\pm 0.025\%$	First 2 digits are significant numbers 3rd digit indicates number of zeros	Special feature code number