



厦门华联电子有限公司

Xiamen Hualian Electronics Co., Ltd.

产品规格书

SPECIFICATION

产品名称：绿色超高亮发光二极管

DESCRIPTION: GREEN SUPER BRIGHT LED

型号 MODEL: HFGA05024CP-23

电 话：(0592) 6037469

传 真：(0592) 6037471

E-mail : xmhlec@public.xm.fj.cn

Website : www.xmhl.com

地 址：厦门火炬高技术产业开发区华联电子大厦

邮 编：361006

1、特点 (FEATURES) :

- 驱动电流低, 发光强度高。 Low Drive Current, High Intensity of Light Emission.
- 快速响应时间, 可用脉冲驱动。 Fast Response Time, Pulse Driven.
- 环氧树脂无色透明封装。 Water clear Plastic Molding.

2、极限参数 (ABSOLUTE MAXIMUM RATINGS) (Ta=25°C):

参数名称 PARAMETER	符号 SYMBOL	额定值 RATING	单位 UNIT
正向脉冲电流(1) Forward Pulse Current	I_{FPM}	100	mA
正向电流 Forward Current	I_{FM}	50	mA
反向电压 Reverse Voltage	V_R	5	V
耗散功率 Power Dissipation	P_D	150	mW
工作温度 Operating Temperature	T_{opr}	-25 - +80	°C
贮存温度 Storage Temperature	T_{stg}	-30 - +100	°C
焊接温度 (5 秒) (2) Soldering Heat (5s)	T_{sol}	260	°C

(1) 占空比 Duty: 1/10, 频率 Frequency: 1KHz

(2) 离器件本体 2 mm 以上 Up to 2 mm from the body.

3、光电参数 (OPTOELECTRIC CHARACTERISTICS) (Ta=25°C):

参数名称 PARAMETER	符号 SYMBOL	测试条件 TEST CONDITION	最小值 MIN	典型值 TYP	最大值 MAX	单位 UNIT
正向电压 Forward Voltage	V_F	$I_F = 20mA$	-	3.3	3.8	V
反向电流 Reverse Current	I_R	$V_R = 5V$	-	-	50	μA
发光强度 Luminous Intensity	I_V	$I_F = 20mA$	3.0	5.0	-	cd
主波长 Dominate Wave Length	λ_D	$I_F = 20mA$	-	508	-	nm
光谱半宽度 Spectral Line Half Width	$\Delta \lambda$	$I_F = 20mA$	-	20	-	nm
半强角度 Viewing Angle	$2\theta_{1/2}$	$I_F = 20mA$	-	23	-	度

4、外形尺寸 (DIMENSION)

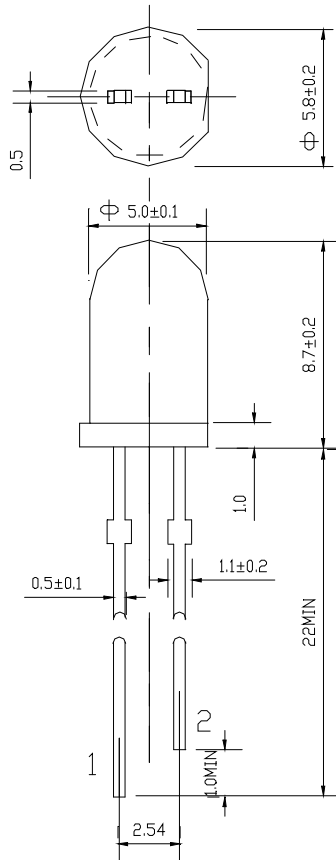

1. 正极 Anode
2. 负极 Cathode

未注公差: ± 0.2 mm

6. 包装方式 **Packing**

6.1 用 220×110mm² 防静电塑料袋内包装，500 只/袋。

Internally packed with 220×110mm² plastic bag anti-statically, 500pcs/bag.

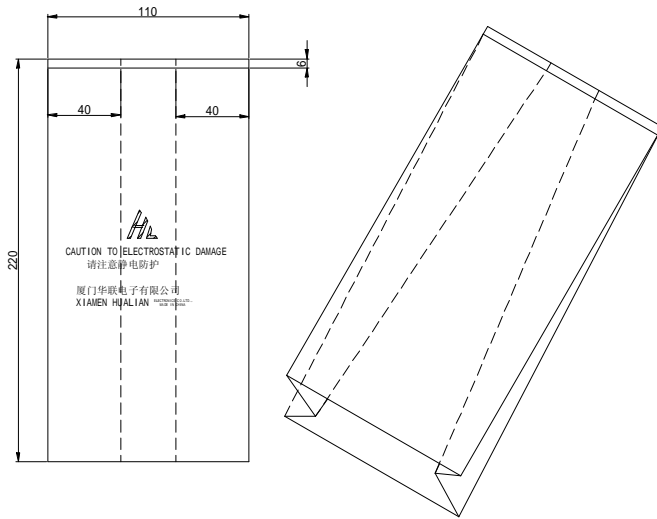

6.2 外包装用纸盒(220×220×190mm)³， 10000 只/盒。

Externally Packed with 220×220×190mm³ cartons, 10000 pcs/carton.

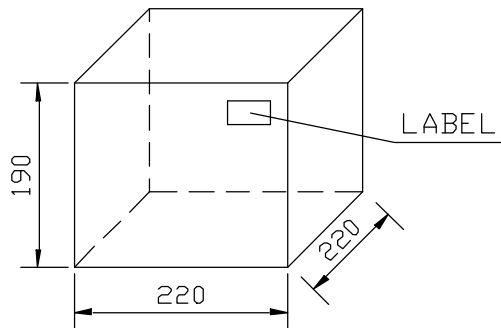

6.3 标识 Label

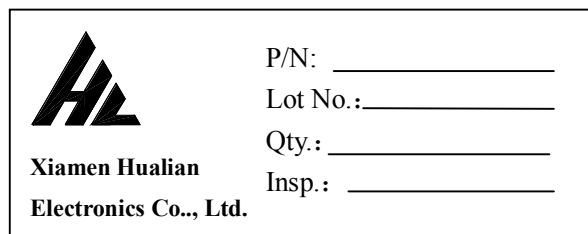

7. 注意事项 **Precautions**

7.1 引线成型 **Forming**

1) 引线成型需在焊接前完成。Leads should be formed before soldering.

- 2) 不能以引线基材为支点成型。Do not form the leads with their bases as a fulcrum.
- 3) 成型位置应离环氧本体 5mm 以上。Forming location should be up to 5mm from the epoxy body.

7.2 安装 Installation

LED 安装在 PCB 上，不能造成对引线施加压力。

Installation on PCB do not apply physical stress to the leads when mounting LED lamps on PCB.

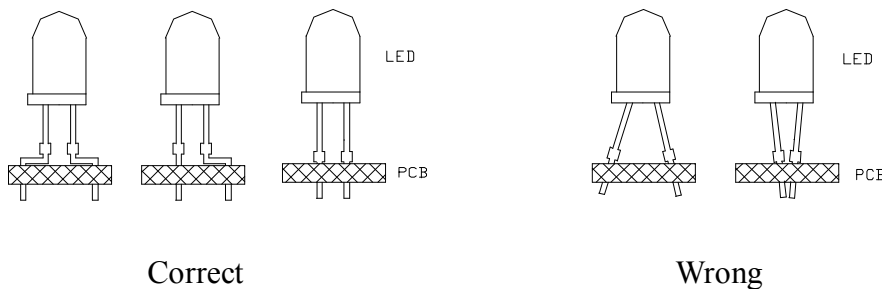

7.3 焊接 Soldering

- 1) 环氧不可浸入锡槽内。Do not dip epoxy body into solder bath.
- 2) 加热过程中不能对引线施加压力。Do not apply stress to the leads while they are heated.
- 3) 使用电烙铁焊接时，电烙铁的功率应小于等于 30W，焊接时间应小于 3 秒。

When soldering LED, the solder iron power should be not more than 30W and with the soldering time not more than 3 seconds.

9.4 清洗 Cleaning

- 1) 在任何情况下，清洗时间应在常温 1 分钟之内进行。

In any case, the cleaning time should be 1 minute or less at a normal temperature.

- 2) 不可用水清洗，以免腐蚀引线，推荐使用酒精。

Do not clean LEDs with water as the remains may rust the leads. Alcohol is suggested to be used.

- 3) 用超声波清洗 LED 时，超声功率和时间应分别小于 300W 和 30 秒；PCB 和 LED 不能接触振荡器；不能使 PCB 上 LED 产生共振。

When LEDs are ultrasonic-washed, use the ultrasonic output power of less than 300W and the time of less than 30s; do not let the PCB and LEDs touch on the oscillator; do not resonate the LEDs attached on the PCB.

7.5 超高亮 LED 为静电敏感器件，所以静电和电涌会损坏 LED。要求使用时佩带防静电腕带，

所有的装置、设备、机器、桌子、地面都必须防静电接地。

The ultra bright LED is an electrostatic insensitive device, so static electricity and surge will damage the LED. It is required to wear a wrist-band when handling the LED. All device, equipment, machinery, desk and ground must be properly grounded.

8. 建议使用方式 **Suggested way of usage.**

LED 使用时必须串联一个保护电阻，正向直流电流为 20mA 左右。

When using LED, it must use a protective resistor in series with DC current about 20 mA.