



### Description

RightSight photoelectric sensors offer high-performance general purpose sensing in a compact, flexible package. They are designed for applications where simplified installation and maintenance are required. Suitable for general purpose environments, these sensors can also be used in areas where a rugged photoelectric sensor is required.

RightSight sensors can be through-hole mounted flush against a mounting surface, or can be attached with an 18mm threaded mounting nose or base. Just 35mm (1.4in) deep, the RightSight can be used in many areas where industry-standard 18mm mounting is desired and a short mounting depth is required.

Designed to withstand the rigors of food processing and material handling environments, all RightSight sensors can withstand repeated 8270kPa (1200 psi) high temperature washdowns.

Highly visible indicators allow quick verification of operation from a wide viewing area. Three indicators display power, output, and operating margin status. The margin indicator verifies a minimum 2.5X operating margin and flashes if an output is shorted.

To simplify installation and configuration, only those sensing modes which require sensitivity adjustments (fiber optic and diffuse) contain a one-turn knob on the top of the sensor.

RightSight photoelectric sensors are available in two types:

**Standard On/Off** sensors offer a fast 1ms response time and 10.8–30V DC operation. They have a shorter mounting base and can be ordered with either NPN or PNP complementary light/dark operate outputs. For extra flexibility, models with universal voltage 21.6–264V AC/DC may be selected. These sensors have a longer mounting base and provide a MOSFET output which is short-circuit protected across the entire voltage range. Both light/dark operate models are available.

**DeviceNet™ Compatible** sensors interface directly to this industry-standard plant floor network. They not only provide simple On/Off indication, but also advanced logic and diagnostic information. These include timers, counters, motion detection, and static or dynamic margin diagnostics. Each sensor may be programmed for COS (change-of-state) or strobing protocol operation. Refer to page 8–6 for a complete description.

### Features

- Compact right angle housing
- Flexible 18mm mounting options
- 1200psi washdown rating
- No user adjustments
- 360° visible LED indicators
- Reverse polarity protection
- Short-circuit protected outputs
- Fast 1ms response time (DC)
- False pulse protection

### General Information

General Specifications . . . . .	page 1–32
Wiring Diagrams . . . . .	page 1–33
Dimensions . . . . .	page 1–33

### Sensing Modes

#### Standard On/Off

Polarized Retroreflective . . . . .	page 1–35
Standard Diffuse . . . . .	page 1–36
Sharp Cutoff Diffuse . . . . .	page 1–37
Background Suppression . . . . .	page 1–38
Transmitted Beam . . . . .	page 1–40
Infrared Glass Fiber Optic . . . . .	page 1–42

### Accessories

Quick-Disconnect Cables . . . . .	page 5–1
Mounting Assemblies . . . . .	page 1–301
Apertures . . . . .	page 1–305
Reflectors . . . . .	page 1–311



RightSight DC model with short 18mm base



**Features**

- Compact right angle housing
- Flexible 18mm mounting options
- 1200psi washdown rating
- No user adjustments
- 360° visible LED indicators
- Reverse polarity protection
- Short-circuit protected outputs
- Fast 1ms response time (DC)
- False pulse protection

**General Specifications**

	DC	AC/DC
<b>Sensing Modes</b>	See Selection Guide page 1–6	
<b>Unit Protection</b>	False pulse, reverse polarity, overload, short circuit	
<b>Supply Voltage</b>	10.8 to 30V	21.6 to 264V
<b>Current Consumption</b>	35mA max.	25mA max
<b>Output Type</b>	NPN or PNP (by model)	MOSFET
<b>Output Mode</b>	Light/dark operate (both)	Light/dark operate (by model)
<b>Output Rating</b>	100mA @ 30V	100mA @ 264V
<b>Response Time</b>	1ms (4/8ms for T.B.)	8.3ms (16.6ms for T.B.)
<b>Housing Material</b>	Noryl®	
<b>Lens Material</b>	Acrylic	
<b>Cover Material</b>	Udel	
<b>LED Indicators</b>	See table below	
<b>Connection Types</b>	4-pin DC micro QD; 4-pin AC micro QD; 4-pin DC pico QD 2m (6.5ft) 300V PVC cable	
<b>Supplied Accessories</b>	Two 18mm mounting nuts	
<b>Optional Accessories</b>	Cordsets, mounting brackets, reflectors	
<b>Operating Environment</b>	NEMA 4X, 6P, IP67 (IEC529); 1200psi (8270kPa) washdown	
<b>Vibration</b>	10–55Hz, 1mm amplitude, Meets or exceeds IEC 60947–5–2	
<b>Shock</b>	30G with 1ms pulse duration, Meets or exceeds IEC 60947–5–2	
<b>Operating Temperature</b>	–25°C to +70°C (–13°F to +158°F) ≥ 132V AC/DC; –25°C to +55°C (–13°F to +131°F) ≤ 132V AC/DC	
<b>Relative Humidity</b>	5% to 95%	
<b>Approvals</b>	UL listed, CSA certified, and CE marked for all applicable directives	

Label	Color	State	Status
Output	Yellow	OFF	Output de-energized
		ON	Output energized
Margin	Orange	OFF	Margin < 2.5
		ON	Margin > 2.5
		Flashing	Output SCP active (short-circuit)
Status	Green	OFF	Sensor not powered
		ON	Sensor powered

**Note:** Green LED turns off when output activated.

**RightSight Nonadjustable Sensor**

**RightSight Adjustable Sensor**

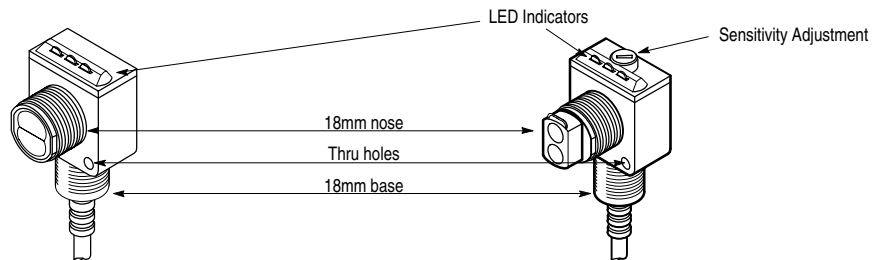

## Wiring Diagrams

### 10.8–30V DC Sensors

#### Models with NPN Outputs

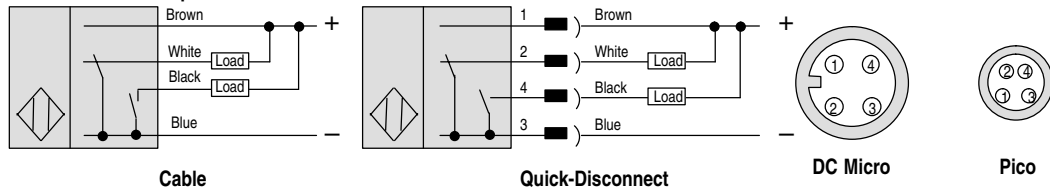

#### Models with PNP Outputs

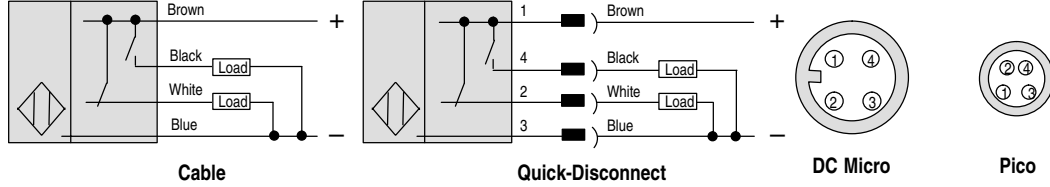

### Transmitted Beam Source—All Models

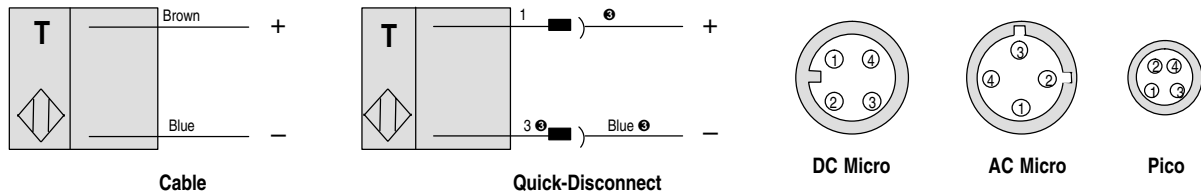

### 21.6–264V AC/DC Sensors

#### AC Wiring

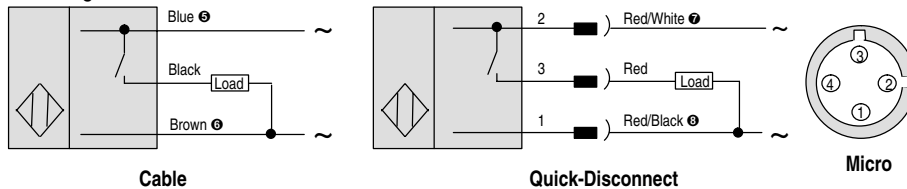

#### DC Wiring for 42EF—C—Models

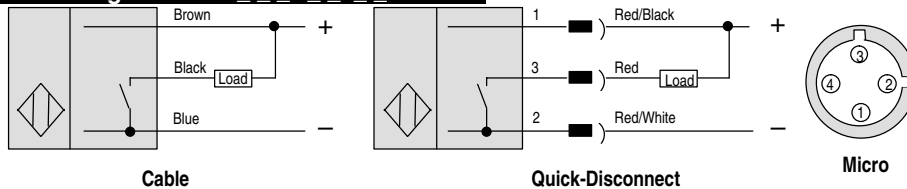

#### DC Wiring for 42EF—F—Models

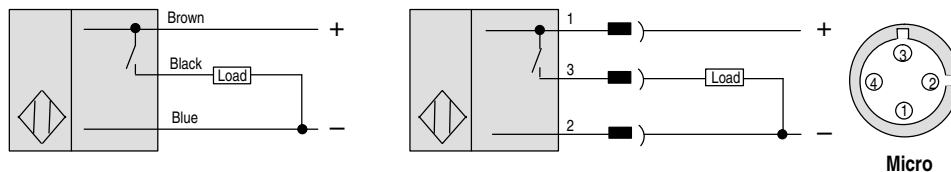

- ① For Allen-Bradley programmable controller compatible interface, refer to publication 42–2.0.
- ② Quick-disconnect wiring codes shown are valid for Allen-Bradley 889D cordsets only.
- ③ Red/black (1) red/wt (2) for AC models.
- ④ Pin 2 for AC models.
- ⑤ Brown for 42EF—F— models.
- ⑥ Blue for 42EF—F— models.
- ⑦ Red/black for 42EF—F— models.
- ⑧ Red/white for 42EF—F— models.

Dimensions—mm (inches)

AC/DC and DeviceNet Models

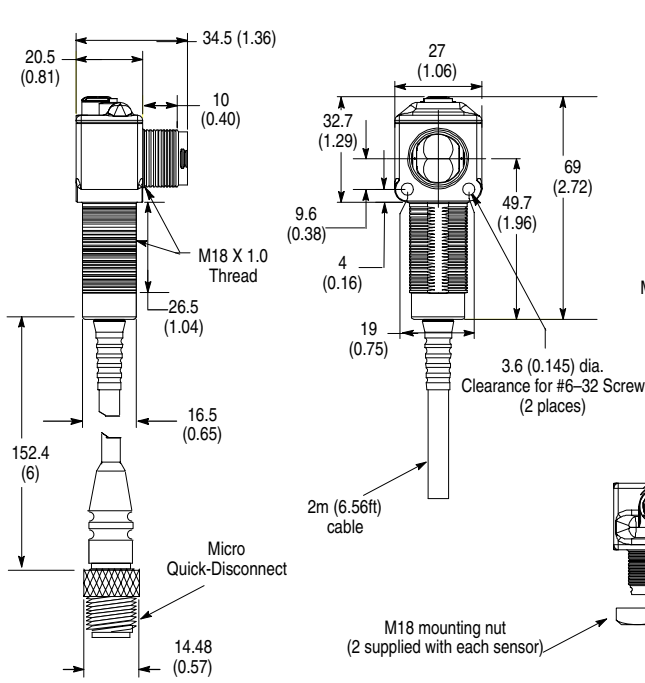

DC Models

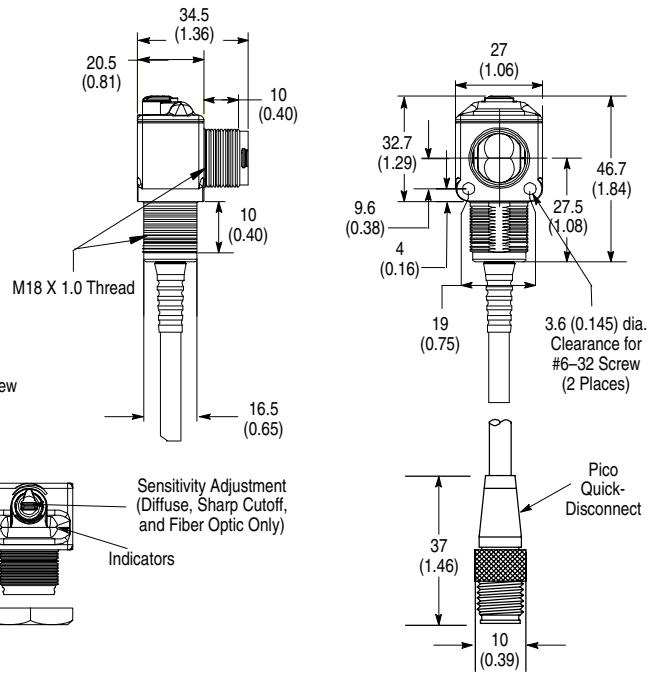

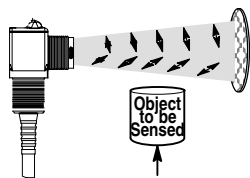

**Description**

RightSight polarized retroreflective sensors can be used to detect most objects, including shiny objects such as shrink wrapped products, bright metals, foils, etc. They are intended primarily for use in applications where an opaque target will completely block the effective beam between sensor and reflector.

**Specifications**

Field of View	1.5°
Emitter LED	Visible Red 660nm

**QD Cordsets and Accessories**

Description	Catalog Number
DC Micro QD Cordset, Straight, 4-pin, 2m	889D-F4AC-2
AC Micro QD Cordset, Straight, 4-pin, 2m	889R-F4AEA-2
Pico QD Cordset, Straight, 4-pin, 2m	889P-F4AB-2
76mm (3in) Diameter with Center Mount Hole	92-39
32mm (1.25in) Diameter	92-47
Mounting Bracket Swivel/Tilt	60-2649

**Typical Response Curve**

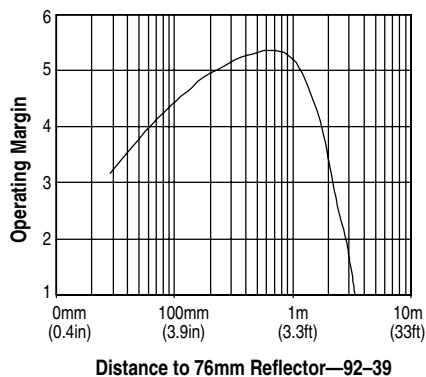

**Beam Pattern**

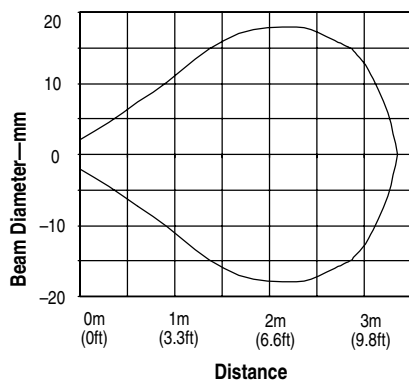

**Selection Guide**

Operating Voltage/Current	Sensing Distance	Output Energized	Output Type/Capacity Response Time	Max Leakage Current	Connection Type	Catalog Number	
10.8–30V DC 35mA	25mm (1in) to 3m (9.8ft)	2 Complementary LO/DO Outputs	NPN/100mA 1ms	0.1mA	2m 300V cable	42EF-P2MNB-A2	
					4-pin DC micro QD	42EF-P2MNB-F4	
			PNP/100mA 1ms		4-pin pico QD	42EF-P2MNB-Y4	
					2m 300V cable	42EF-P2MPB-A2	
			4-pin DC micro QD		42EF-P2MPB-F4		
			4-pin pico QD		42EF-P2MPB-Y4		
21.6–264V AC/DC 15mA	25mm (1in) to 3m (9.8ft)	Dark Operate	NPN MOSFET/100mA 8.3ms	0.4mA	2m 300V cable	42EF-P2SCB-A2	
		Light Operate			4-pin AC micro QD	42EF-P2SCB-G4	
					2m 300V cable	42EF-P2RCB-A2	
		Dark Operate	PNP MOSFET/100mA 8.3ms		0.01mA	4-pin AC micro QD	42EF-P2RCB-G4
						2m 300V cable	42EF-P2SFB-A2
			Light Operate			4-pin AC micro QD	42EF-P2SFB-G4
2m 300V cable	42EF-P2RFB-A2						
4-pin AC micro QD	42EF-P2RFB-G4						

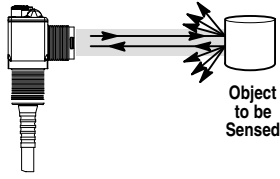

**Specifications**

Field of View	5°
Emitter LED	Infrared 880nm

**QD Cordsets and Accessories**

Description	Catalog Number
DC Micro QD Cordset, Straight, 4-pin, 2m	889D-F4AC-2
AC Micro QD Cordset, Straight, 4-pin, 2m	889R-F4AEA-2
Pico QD Cordset, Straight, 4-pin, 2m	889P-F4AB-2
Mounting Bracket Swivel/Tilt	60-2649

**Description**

RightSight standard diffuse sensors are designed to detect light directly reflected by the target surface. The nominal range of these sensors is measured to a standard white paper target. Actual range will depend on the reflectivity of the target.

A single turn sensitivity adjustment is provided to maximize sensor performance in various applications. Successful application of standard diffuse sensors can be challenging, and caution must be used to avoid detecting the background behind the target, or detecting other objects in the target area.

**Typical Response Curve**

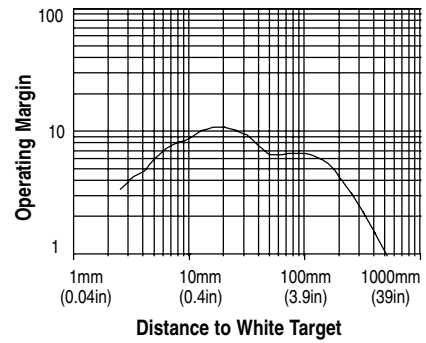

**Beam Pattern**

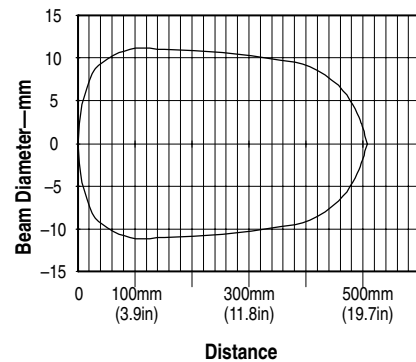

**Selection Guide**

Operating Voltage/Current	Sensing Distance	Output Energized	Output Type/Capacity Response Time	Max Leakage Current	Connection Type	Catalog Number
10.8–30V DC 35mA	3mm (0.12in) to 500mm (20in)	2 Complementary LO/DO Outputs	NPN/100mA 1ms	0.1mA	2m 300V cable	42EF-D1MNAK-A2
					4-pin DC micro QD	42EF-D1MNAK-F4
			4-pin pico QD		42EF-D1MNAK-Y4	
			2m 300V cable		42EF-D1MPAK-A2	
			4-pin DC micro QD		42EF-D1MPAK-F4	
			4-pin pico QD		42EF-D1MPAK-Y4	
21.6–264V AC/DC 15mA	3mm (0.12in) to 500mm (20in)	Light Operate	NPN MOSFET/100mA 8.3ms	0.4mA	2m 300V cable	42EF-D1RCAK-A2
					4-pin AC micro QD	42EF-D1RCAK-G4
		Dark Operate			2m 300V cable	42EF-D1SCAK-A2
		4-pin AC micro QD			42EF-D1SCAK-G4	
		Light Operate			2m 300V cable	42EF-D1RFAK-A2
					4-pin AC micro QD	42EF-D1RFAK-G4
Dark Operate	2m 300V cable	42EF-D1SFAK-A2				
	4-pin AC micro QD	42EF-D1SFAK-G4				

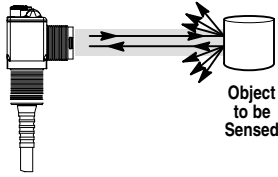

### Specifications

Field of View	7°
Emitter LED	Infrared 880nm

### QD Cordsets and Accessories

Description	Catalog Number
DC Micro QD Cordset, Straight, 4-pin, 2m	889D-F4AC-2
AC Micro QD Cordset, Straight, 4-pin, 2m	889R-F4AEA-2
Pico QD Cordset, Straight, 4-pin, 2m	889P-F4AB-2
Mounting Bracket Swivel/Tilt	60-2649

### Typical Response Curve

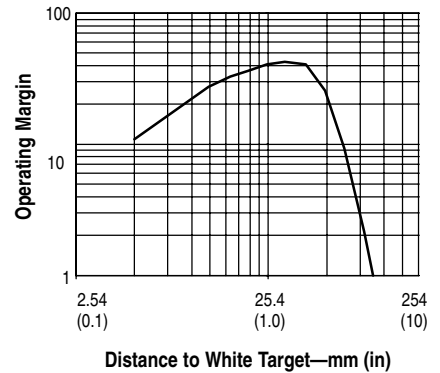

### Description

Sharp cutoff diffuse sensors are ideal for short range applications where it is desirable to detect reflections from the target surface, yet ignore reflections from background surfaces or objects directly behind the target.

These sensors are also especially suited for use in applications when high frequency lighting is present. This type of lighting can false trigger conventional photoelectric sensor. The RightSight sharp cutoff diffuse sensor will provide between 10 and 40 times more immunity when compared to a conventional photoelectric sensor.

A single turn sensitivity adjustment is provided to maximize sensor performance in various applications.

### Beam Pattern

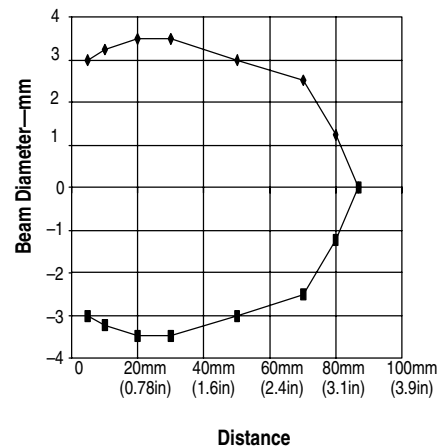

### Selection Guide

Operating Voltage/Current	Sensing Distance	Output Energized	Output Type/Capacity Response Time	Max Leakage Current	Connection Type	Catalog Number
10.8–30V DC 25mA	3mm (0.12in) to 130mm (5in)	2 Complementary LO/DO Outputs	PNP/100mA 1ms	0.1mA	2m 300V cable	42EF-S1MPA-A2
					4-pin DC micro QD	42EF-S1MPA-F4
					4-pin pico QD	42EF-S1MPA-Y4
			NPN/100mA 1ms		2m 300V cable	42EF-S1MNA-A2
					4-pin DC micro QD	42EF-S1MNA-F4
					4-pin pico QD	42EF-S1MNA-Y4
21.6–264V AC/DC 15mA	3mm (0.12in) to 130mm (5in)	Light Operate	NPN MOSFET/100mA 8.3ms	0.4mA	2m 300V cable	42EF-S1RCA-A2
		Dark Operate			4-pin AC micro QD	42EF-S1RCA-G4
					2m 300V cable	42EF-S1SCA-A2
		4-pin AC micro QD			42EF-S1SCA-G4	
21.6–132V AC/DC 15mA	3mm (0.12in) to 130mm (5in)	Light Operate	PNP MOSFET/100mA 8.3ms	0.01mA	2m 300V cable	42EF-S1RFA-A2
		Dark Operate			4-pin AC micro QD	42EF-S1RFA-G4
					2m 300V cable	42EF-S1SFA-A2
		4-pin AC micro QD			42EF-S1SFA-G4	

# RightSight™ Background Suppression

Standard On/Off

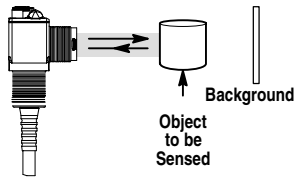

## Specifications

<b>Field of View</b>	50mm (2in): 20° 100mm (3.9in): 8°
<b>Emitter LED</b>	Infrared 880nm

## Description

Background suppression sensors are ideal for short range applications where it is desirable to detect reflections from the target surface, yet ignore reflections from background surfaces or objects directly behind the target.

Background suppression sensors contain two active photoelectric sensing elements, calibrated to detect objects in front of and behind the nominal sensing distance. When a target is not present, the sensor can actively detect a background and turn the output on or off.

RightSight background suppression sensors are among the easiest photoelectric sensors to apply. The sensors are non-adjustable to simplify installation and maintenance. Select the appropriate target range: 50mm (2.0in) or 100mm (3.9in) and RightSight will automatically reject most reflections beyond that range.

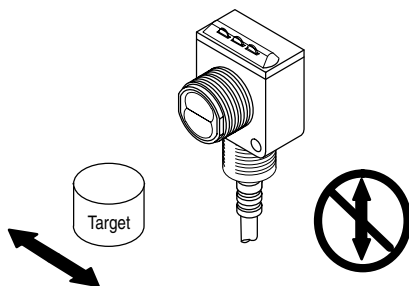

Due to the detection method, targets traveling horizontal to the sensor's optics are detected, i.e., left to right or front to back. Targets traveling vertically may not be accurately detected.

For reliable background suppression, a minimum separation distance of 6mm (0.24in) is recommended between the target and the background.

## QD Cordsets and Accessories

Description	Catalog Number
DC Micro QD Cordset, Straight, 4-pin, 2m	889D-F4AC-2
AC Micro QD Cordset, Straight, 4-pin, 2m	889R-F4AEA-2
Pico QD Cordset, Straight, 4-pin, 2m	889P-F4AB-2
Mounting Bracket Swivel/Tilt	60-2649

## Typical Response Curves

### 50mm

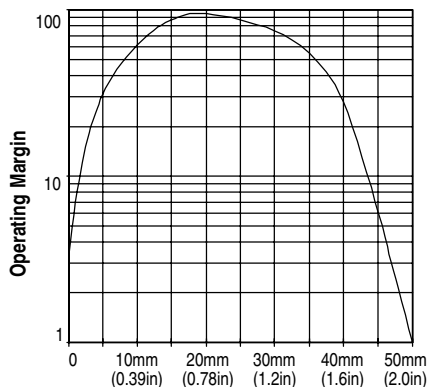

Distance to White Target

### 100mm

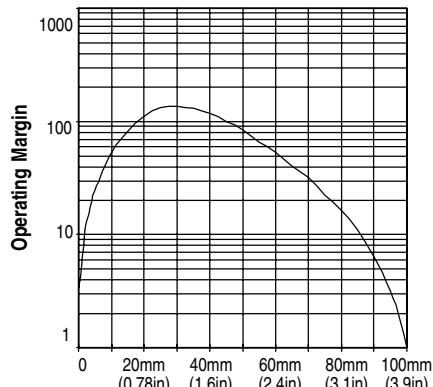

Distance to White Target

## Beam Patterns

### 50mm

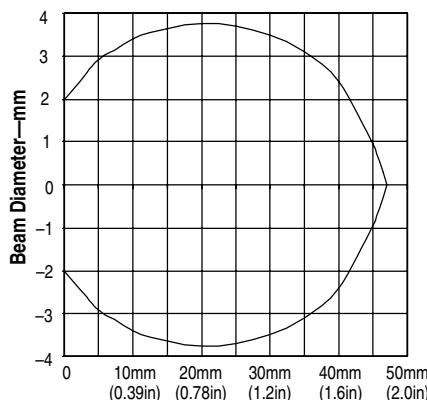

Distance

### 100mm

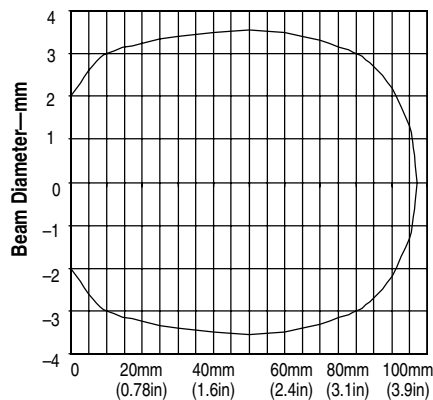

Distance



**Selection Guide**

Operating Voltage/ Current	Sensing Distance	Output Energized	Output Type/ Capacity Response Time	Max Leakage Current	Connection Type	Catalog Number					
10.8–30V DC 35mA	3mm (0.12in) to 50mm (2in)	2 Complementary LO/DO Outputs	NPN 100mA 1ms	0.1mA	2m 300V cable	42EF–B1MNBC–A2					
					4-pin DC micro QD	42EF–B1MNBC–F4					
					4-pin pico QD	42EF–B1MNBC–Y4					
			2m 300V cable		42EF–B1MPBC–A2						
			4-pin DC micro QD		42EF–B1MPBC–F4						
			4-pin pico QD		42EF–B1MPBC–Y4						
	3mm (0.12in) to 100mm (3.9in)		NPN 100mA 1ms		2m 300V cable	42EF–B1MNBE–A2					
					4-pin DC micro QD	42EF–B1MNBE–F4					
					4-pin pico QD	42EF–B1MNBE–Y4					
			2m 300V cable		42EF–B1MPBE–A2						
			4-pin DC micro QD		42EF–B1MPBE–F4						
			4-pin pico QD		42EF–B1MPBE–Y4						
21.6–264V AC/DC 15mA	3mm (0.12in) to 50mm (2in)	Light Operate	NPN MOSFET 100mA 8.3ms	0.4mA	2m 300V cable	42EF–B1RCBC–A2					
		Dark Operate			4-pin AC micro QD	42EF–B1RCBC–G4					
		3mm (0.12in) to 100mm (3.9in)			Light Operate	2m 300V cable	42EF–B1SCBC–A2				
					Dark Operate	4-pin AC micro QD	42EF–B1SCBC–G4				
	3mm (0.12in) to 100mm (3.9in)	Light Operate			2m 300V cable	42EF–B1RCBE–A2					
					4-pin AC micro QD	42EF–B1RCBE–G4					
					Dark Operate	2m 300V cable	42EF–B1SCBE–A2				
						4-pin AC micro QD	42EF–B1SCBE–G4				
		21.6–132V AC/DC 15mA				3mm (0.12in) to 50mm (2in)	Light Operate	PNP MOSFET/100mA 8.3ms	0.01mA	2m 300V cable	42EF–B1RFBC–A2
							Dark Operate			4-pin AC micro QD	42EF–B1RFBC–G4
					3mm (0.12in) to 100mm (3.9in)		Light Operate			2m 300V cable	42EF–B1SFBC–A2
							Dark Operate			4-pin AC micro QD	42EF–B1SFBC–G4
3mm (0.12in) to 100mm (3.9in)	Light Operate		2m 300V cable	42EF–B1RFBE–A2							
			4-pin AC micro QD	42EF–B1RFBE–G4							
			Dark Operate	2m 300V cable	42EF–B1SFBE–A2						
				4-pin AC micro QD	42EF–B1SFBE–G4						

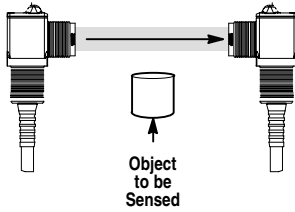

**Description**

For most applications, transmitted beam sensing provides the most reliable operation. Transmitted beam sensing generally provides the highest operation margin, reducing the need for cleaning of sensor lenses or reflective targets. Transmitted beam sensing is also typically the best choice for sensing in difficult environments where dust, mist, and other contaminants are present.

RightSight transmitted beam sensors are available in both short and long ranges, 4m (13ft) and 20m (66ft), respectively. The short-range version is ideally suited for installation in high noise environments where the sensor will be mounted close to motor starters, variable speed drives and other high frequency devices. The long-range version should only be used when the sensing distance exceeds 4m (13ft).

Easily mounted slit apertures are available for use when sensing smaller objects at reduced ranges.

The beam pattern for a transmitted beam sensor represents the boundary within which the receiver responds to the emitter, assuming there is no angular misalignment. Angular misalignment between the emitter and receiver will decrease the size of the sensing area. Margins shown are achieved when sensors are used in matched operating voltage pairs, i.e., AC/DC emitter with AC/DC receiver or DC emitter with DC receiver.

**Specifications**

Field of View	7°
Emitter LED	Infrared 880nm

**QD Cordsets and Accessories**

Description	Catalog Number
DC Micro QD Cordset, Straight, 4-pin, 2m	889D-F4AC-2
AC Micro QD Cordset, Straight, 4-pin, 2m	889R-F4AEA-2
Pico QD Cordset, Straight, 4-pin, 2m	889P-F4AB-2
Apertures, 1mm slot	60-2660
Apertures, 2mm slot	60-2661
Apertures, 4mm slot	60-2662
Aperture set	60-2659
Mounting Bracket Swivel/Tilt	60-2649

**Apertures**

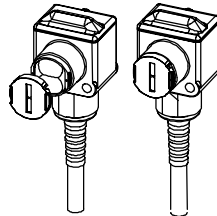

Note: 18mm nut must be installed prior to installing aperture if threads on optics snout are to be used.

- 1mm Qty. 20 #60-2660
- 2mm Qty. 20 #60-2661
- 4mm Qty. 20 #60-2662
- Aperture Set (4 each) #60-2659

**Typical Response Curve**

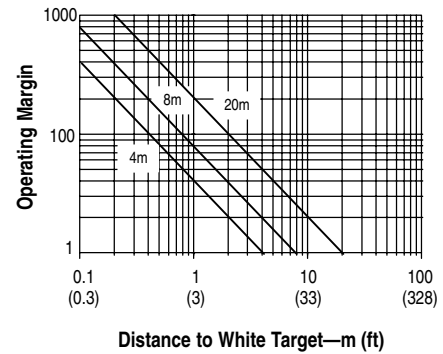

**Beam Pattern**

**4m Receiver Models**

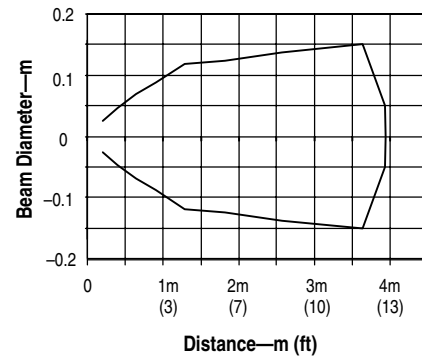

**20m Receiver Models**

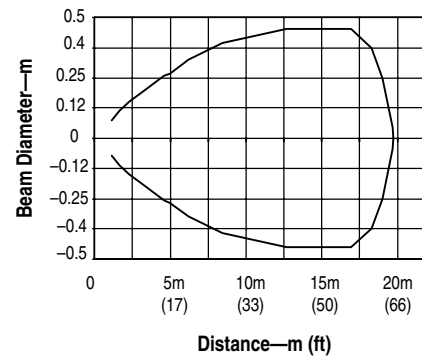

**Selection Guide for Light Sources**

Operating Voltage Supply Current	Max Sensing Distance	Connection Type	Catalog Number
10.8–30V DC 25mA	Depends on Receiver	2m 300V cable	42EF-E1EZB-A2
		4-pin micro QD	42EF-E1EZB-F4
		4-pin pico QD	42EF-E1EZB-Y4
21.6–264V AC/DC 15mA		2m 300V cable	42EF-E1QZB-A2
		4-pin micro QD	42EF-E1QZB-G4
		4-pin pico QD	42EF-E1QZB-Y4

**Selection Guide for Receivers**

Operating Voltage/ Current	Operating Distance	Output Energized	Output Type/ Capacity Response Time	Max Leakage Current	Connection Type	Catalog Number
10.8–30V DC 25mA	25mm (1in) to 4m (13ft)	2 Complementary LO/DO Outputs	NPN/100mA 4ms	0.1mA	2m 300V cable	42EF-R9MNBV-A2
					4-pin DC micro QD	42EF-R9MNBV-F4
					4-pin DC pico QD	42EF-R9MNBV-Y4
			PNP/100mA 4ms		2m 300V cable	42EF-R9MPBV-A2
					4-pin DC micro QD	42EF-R9MPBV-F4
					4-pin DC pico QD	42EF-R9MPBV-Y4
21.6–132V AC/DC 15mA	25mm (1in) to 4m (13ft)	Dark Operate	PNP MOSFET/100mA 8.3ms	0.01mA	2m 300V cable	42EF-R9SFBV-A2
		Light Operate			4-pin AC micro QD	42EF-R9SFBV-G4
		Dark Operate			2m 300V cable	42EF-R9RFBV-A2
					4-pin AC micro QD	42EF-R9RFBV-G4
21.6–264V AC/DC 15mA	25mm (1in) to 4m (13ft)	Light Operate	NPN MOSFET/100mA 16.6ms	0.4mA	2m 300V cable	42EF-R9SCBV-A2
		Dark Operate			4-pin AC micro QD	42EF-R9SCBV-G4
					2m 300V cable	42EF-R9RCBV-A2
		4-pin AC micro QD			42EF-R9RCBV-G4	
10.8–30V DC 25mA	25mm (1in) to 8m (26.25ft)	2 Complementary LO/DO Outputs	NPN/100mA 4ms	0.1mA	2m 300V cable	42EF-R9MNBV-A2
					4-pin DC micro QD	42EF-R9MNBV-F4
					4-pin DC pico QD	42EF-R9MNBV-Y4
			PNP/100mA 4ms		2m 300V cable	42EF-R9MPBV-A2
					4-pin DC micro QD	42EF-R9MPBV-F4
					4-pin DC pico QD	42EF-R9MPBV-Y4
21.6–264V AC/DC 15mA	25mm (1in) to 8m (26.25ft)	Dark Operate	NPN MOSFET/100mA 16.6ms	0.4mA	2m 300V cable	42EF-R9SCBT-A2
		Light Operate			4-pin AC micro QD	42EF-R9SCBT-G4
		Dark Operate			2m 300V cable	42EF-R9RCBT-A2
					4-pin AC micro QD	42EF-R9RCBT-G4
10.8–30V DC 25mA	25mm (1in) to 20m (66ft)	2 Complementary LO/DO Outputs	NPN/100mA 8ms	0.1mA	2m 300V cable	42EF-R9MNB-A2
					4-pin DC micro QD	42EF-R9MNB-F4
					4-pin DC pico QD	42EF-R9MNB-Y4
			PNP/100mA 8ms		2m 300V cable	42EF-R9MPB-A2
					4-pin DC micro QD	42EF-R9MPB-F4
					4-pin DC pico QD	42EF-R9MPB-Y4
21.6–264V AC/DC 15mA	25mm (1in) to 20m (66ft)	Dark Operate	NPN MOSFET/100mA 16.6ms	0.4mA	2m 300V cable	42EF-R9SCB-A2
		Light Operate			4-pin AC micro QD	42EF-R9SCB-G4
		Dark Operate			2m 300V cable	42EF-R9RCB-A2
					4-pin AC micro QD	42EF-R9RCB-G4

**Note:** For maximum performance, transmitted beam sources should be combined with matched operating voltage receivers, i.e., AC/DC source with AC/DC receiver or DC source with DC receiver. Reduced operating distance and margin will result from mixed operating voltage pairs.

# RightSight™ Infrared Glass Fiber Optic

Standard On/Off

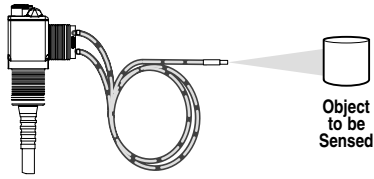

## Specifications

<b>Field of View</b>	Depends on Glass Fiber Optic cable selected
<b>Emitter LED</b>	Infrared 880nm

## QD Cordsets and Accessories

Description	Catalog Number
DC Micro QD Cordset, Straight, 4-pin, 2m	889D-F4AC-2
AC Micro QD Cordset, Straight, 4-pin, 2m	889R-F4AEA-2
Pico QD Cordset, Straight, 4-pin, 2m	889P-F4AB-2
Mounting Bracket Swivel/Tilt	60-2649

## Description

RightSight infrared fiber optic sensors are best suited for applications where the sensor cannot be placed at the actual sensing position. Infrared sensors with glass fiber optic cables provide the greatest sensing distances and are the most stable when sensing a wide variety of colors.

RightSight glass fiber optic sensors will withstand repeated 8270kPa (1200psi) washdowns when used with any Allen-Bradley glass fiber optic cable. However, for best results, PVC sheathed glass fiber optic cables are recommended for use in applications where washdown will occur.

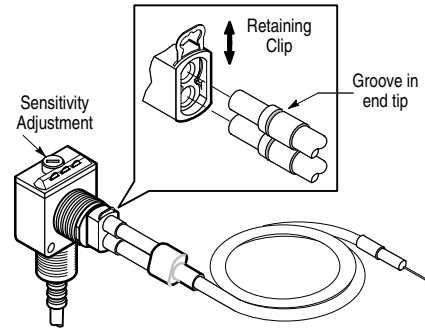

## Glass Fiber Optic Cables—mm (inches)

Sensing Mode	Glass Fiber Dia.	Fiber Model	Typical Range
Diffuse (Bifurcated Fiber)	3.1 (0.125)	99-32-1	38 (1.5)
	1.1 (0.046)	99-275-1	21 (0.8)
Transmitted Beam (Individual Fiber)	3.1 (0.125)	99-50-1	457 (18)
	1.1 (0.046)	99-715-1	152 (6)

## Selection Guide

Operating Voltage/Current	Sensing Distance	Output Energized	Output Type/Capacity Response Time	Max Leakage Current	Connection Type	Catalog Number					
10.8–30V DC 35mA	Depends on Glass Fiber Optic cable selected	2 Complementary LO/DO Outputs	NPN/100mA 1ms	0.1mA	2m 300V cable	42EF-G1MNA-A2					
					4-pin DC micro QD	42EF-G1MNA-F4					
					4-pin pico QD	42EF-G1MNA-Y4					
			PNP/100mA 1ms		2m 300V cable	42EF-G1MPA-A2					
					4-pin DC micro QD	42EF-G1MPA-F4					
					4-pin pico QD	42EF-G1MPA-Y4					
21.6–264V AC/DC 15mA	Depends on Glass Fiber Optic cable selected	Light Operate	NPN MOSFET/100mA 8.3ms	0.4mA	2m 300V cable	42EF-G1RCA-A2					
					4-pin AC micro QD	42EF-G1RCA-G4					
					Dark Operate	2m 300V cable	42EF-G1SCA-A2				
						4-pin AC micro QD	42EF-G1SCA-G4				
					21.6–132V AC/DC 15mA	Depends on Glass Fiber Optic cable selected	Light Operate	PNP MOSFET/100mA 8.3ms	0.01mA	2m 300V cable	42EF-G1RFA-A2
										4-pin AC micro QD	42EF-G1RFA-G4
Dark Operate	2m 300V cable	42EF-G1SFA-A2									
	4-pin AC micro QD	42EF-G1SFA-G4									