

High Brightness / High Reliability character

3528Package type TopView Chip LED

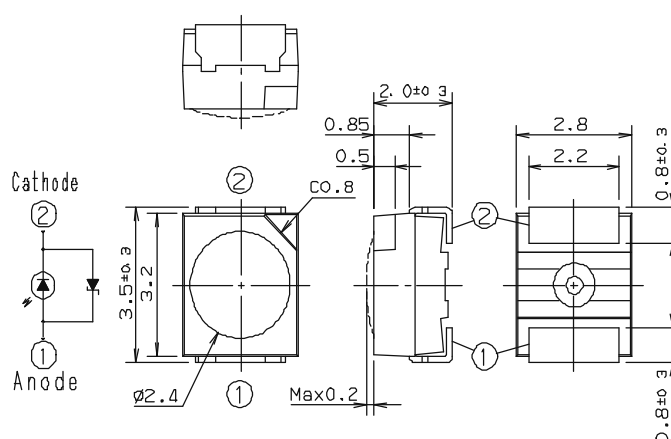
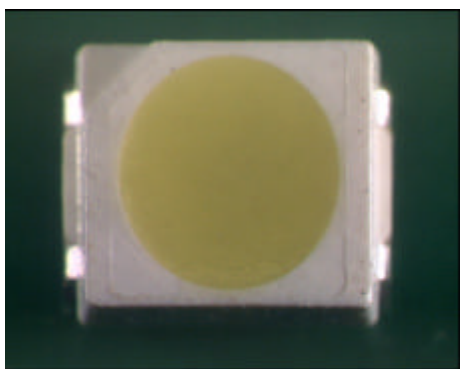

■ Overview

Supported varied color combination of White / Pink / Sky Blue / Yellow of GaN

High brightness, high reliability character chip LED

■ Features

1. GaN dies + Non YAG phosphor (Inorganic type)
2. High brightness LED of GaN
Lineup for White, Sky Blue, Yellow, Pink
(Other existing color of Blue and Green)
3. Since a luminescence color selects a fluorescent substance and corresponds, the product deployment which shared basic specification is possible for it.
4. Basic specification is the high reliability design which aimed at loading to automotive.



■ Applications

Automotive LED and Indicator

■ Dimension

3.5mm L × 2.8mm W × 2.0mm H

The products and specification are subject to change without any notice. Please ask for the latest Product Standards to guarantee the satisfaction of your product requirements.

Semiconductor Company, Matsushita Electric Industrial Co., Ltd.

■ Specification

Absolute Maximum Rating

at Ta=25 deg

		Power	Forward Current	Pulse Current	Reverse Current	Reverse Voltage	Operation Temperature	Storage Temperature
		Pd(mA)	IFDC(mA)	IFP(mA)	IRDC(mA)	VR(V)	TOPR(deg)	TSTG(deg)
GaN	Blue	120	30	60	100	---	-40 ~ +100	-40 ~ +100
	White							
	Green							
	Pink							
	Sky Blue							
	Yellow							

*The condition of pulse current I_{FP} : Pulse width 1 ms, Duty 10 %

Electro-Optical Characteristics

at Ta=25deg

	Luminous Intensity		IF (mA)	Forward Voltage		Peak Emission Wavelength	Spectral Line Half Width		Chromatic coordinates		
	Io			VF (V)	P(nm)	(nm)	IF (mA)	X	Y	IF (mA)	
	(mcd)										
	Typ	Min		Typ	Max	Typ	Typ	Typ	Typ		
Blue	90	60	20	3.4	3.9	470	30	20	--	--	20
White	350	220				---	---		0.310	0.310	
Green	350	220				525	45		--	--	
Pink	250	175				---	---		0.350	0.280	
Sky Blue	425	300				---	---		0.160	0.230	
Yellow	310	215				---	---		0.400	0.470	

*Tolerance of Luminous Intensity $\pm 20\%$

Directive Characteristics

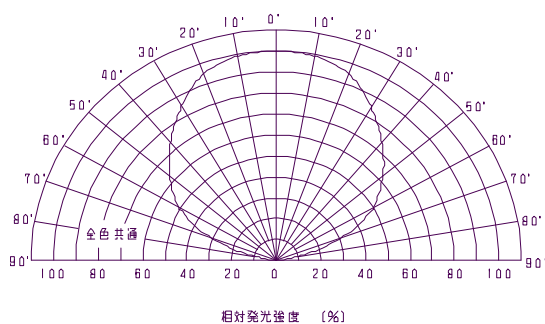

CHROMATICITY DIAGRAM

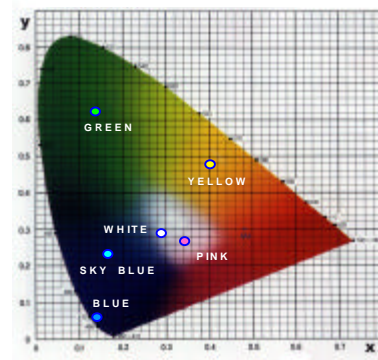

Kind deployment : We can product the same package size LEDs, its color is Red, Soft orange, Amber, and Yellow Green etc. Please contact our sales.