



Main features

- *Pressure range:*
0-10; 0-1000 bar / 0-150; 0-15000 psi
- *Precision class:*
0,3% beyond 50 bar; 0,6% up to 50 bar
- *Entirely in stainless steel*
- *Internally generated calibration signal*
- *Protection level: IP65*
- *Available in intrinsic safety version EEia IIC T6*

Series TPF transducers with flush measurement diaphragm are designed to check the pressure of high-viscosity fluids, which cannot be done with normal transducers with internal measurement chamber.

They are used in the food industry and in plastics processing, up to a temperature of 120°C, and in other applications in which the means of measurement must not stagnate in cavities.

The selection of highly stable electronic components and ultrasonic checking of materials guarantee the absence of inclusions and defects on the primary reaction mechanics, assuring a highly reliable product.

TECHNICAL DATA

Precision class (1)	< 0,3% FSO 0/60...0/1000 bar < 0,6% FSO 0/10...0/50 bar
Resolution	infinite
Pressure range	from 0/10 to 0/1000 bar from 0/150 to 0/15000 psi
Max. applicable pressure (2) (20 sec. without degradation of the specific)	2 times Full Scale (max. 2000bar / 30000psi)
Resistance to bursting	3 times Full Scale (max. 2000bar / 30000psi)
Measurement principle	Metal strain gauge glued (4 active branches)
Resistance of measurement bridge	350 (± 2%) Ohm
Power supply	10 (max 15) Vdc/ac RMS
Resistance of isolation	>1000 MΩ to 50Vdc
Nominal pressure signal	3 (± 1%) mV/V (200...1000bar / 3000...15000 psi) 2 (± 1%) mV/V (50...160bar / 750...1500 psi) 1,5 (± 1%) mV/V (10...40bar / 150...500 psi)
Ambient pressure signal	±1% FSO
Calibration signal	80% ± 1%
Compensated temperature range	-20...+100°C / -4...+212°F
Permitted temperature range	-30...+120°C / -22...+248°F
Option cable F:	-30...+100°C / -22...+212°F
Thermal drift in compensated range (zero - cal. - sens.)	ranges > 50bar (750psi) ±0,02% FSO/°C / ±0,01% FSO/°F ranges ≤ 50bar (750psi) ±0,03% FSO/°C / ±0,02% FSO/°F
Materials in contact with measurement fluid	17- 4 PH stainless steel
Case material	AISI 304 stainless steel
Protection level	IP65
Process connections	Standard: M18x1.5; on request: 3/4-16UNF, 1/2"G male
Electrical connections	6-pole connector; other connectors on request

FSO = Full Scale Output

1 BFSL (Best Fit Straight Line) method

2 tested for more than 1000 strokes with single duration <2msec.

MECHANICAL DIMENSIONS - Process connections

Connection
M18 x 1.5
 (code **G**)

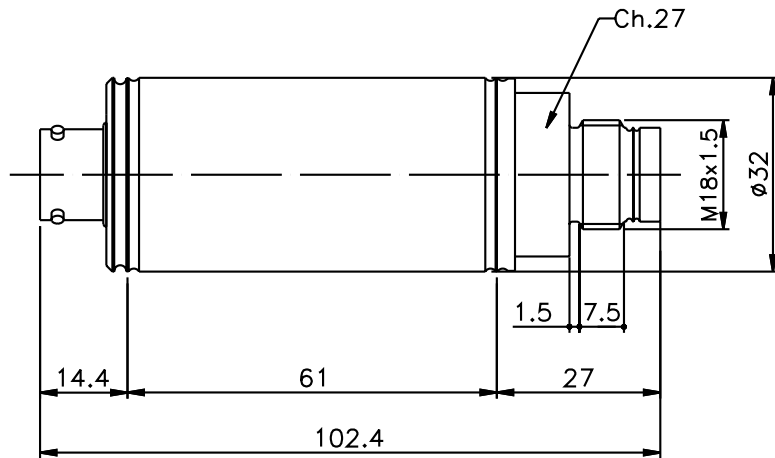

Connection
3/4" - 16 UNF
 (code **L**)

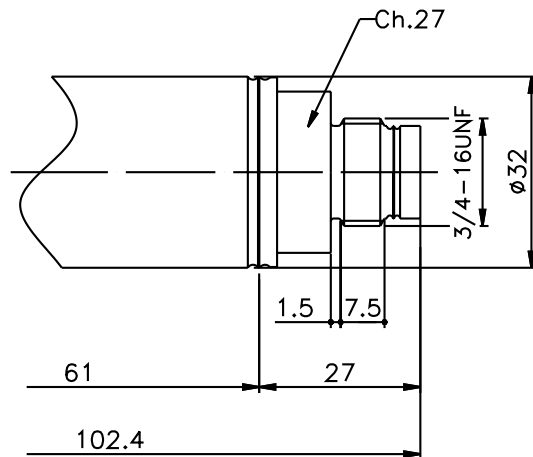

Connection
1/2" G maschio
 (code **M**)

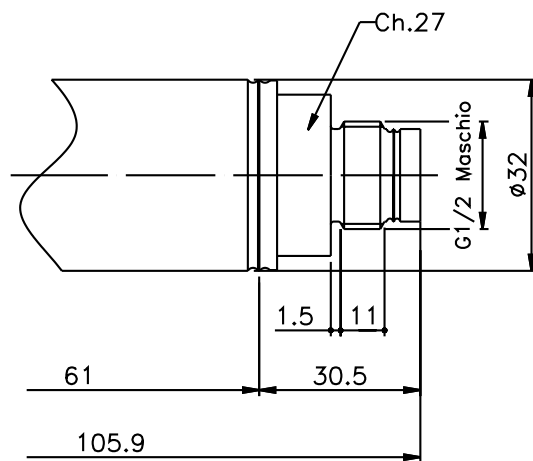

ATTENTION: For installation, use a maximum locking torque of 40Nm.

MECHANICAL DIMENSIONS - Connectors

P - 7-pole connector

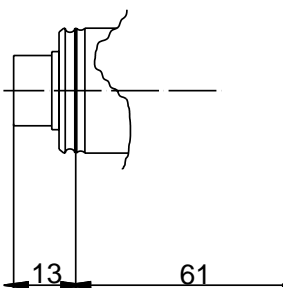

F - 4/6-pole cable

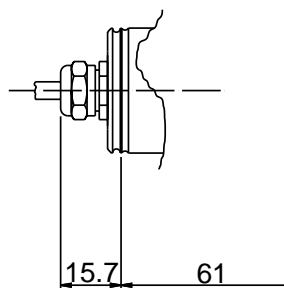

E - 4-pole connector solenoid

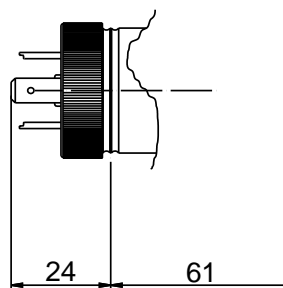

M - 4-pole connector microsolenoid

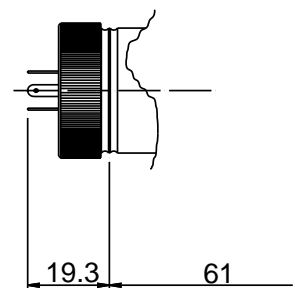

ELECTRICAL CONNECTIONS - Connectors

V - 6-pole connector

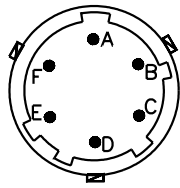

Male Connector
VPT02A10-6PT2

P - 7-pole connector

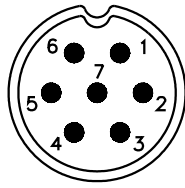

Male Connector
09-0127-09-07

F - 6-pole cable

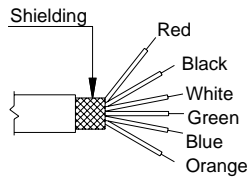

F - Shielded cable 6 x 0,25 - 1m.

E - 4-pole connector solenoid
M - 4-pole connector microsolenoid

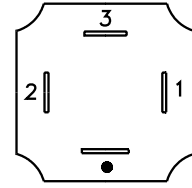

E - Solenoid 400DIN
46350A-ISO 4400
M - Microsolenoid 400 DIN
46350B-ISO 4400

ELECTRICAL CONNECTIONS - connection diagrams

mV/V output

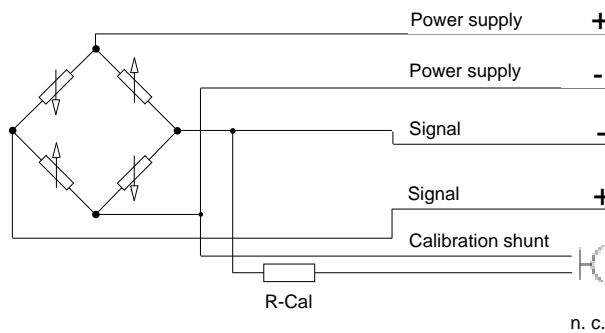

Code V	Code P	Code F	Code E/M
C	1	White	3
D	2	Green	
B	4	Black	2
A	3	Red	1
E - F	5 - 6	Blue/orange	Not available
	7		

The cable sheathing is connected to the transducer body

ACCESSORIES ON REQUEST

Connectors

Connection V

Female cable connector Prot. IP66

CON 300

Connection P

Female cable connector Prot. IP40

CON 320

Female cable connector 90° Prot. IP40

CON 322

Female cable connector Prot. IP67

CON 321

Connection E

Connector 3 poles + ground DIN43650A ISO4400 Prot. IP65 **CON 006**

Connection M

Connector 3 poles + ground DIN43650B ISO4400 Prot. IP65 **CON 008**

ORDER CODE

Pressure transducer

TPF

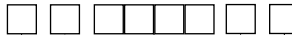

PROCESS CONNECTIONS		
Standard		
M18 x 1.5	G	
On request		
3/4"-16 UNF	L	
1/2" G male	M	

ELECTRICAL CONNECTIONS		
Standard		
6-pole connector	V	
On request		
7-pole connector	P	
6-pole shielded cable	F	
4-pole connector solenoid	E	
4-pole connector microsolenoid	M	

Mechanical and/or electrical characteristics differing from standard may be arranged on request

EXPLOSION-PROOF VERSION	
EX	Certification EEx ia IIC T6

PRESSURE RANGE			
	bar		psi
B01D	0..10	P15D	0..150
B16U	0..16	P03C	0..300
B02D	0..20	P05C	0..500
B25U	0..25	P75D	0..750
B03D	0..30	P15C	0..1500
B35U	0..35	P03M	0..3000
B04D	0..40	P05M	0..5000
B05D	0..50	P75C	0..7500
B06D	0..60	P10M	0..10000
B01C	0..100	P15M	0..15000
B16D	0..160		
B02C	0..200		
B25D	0..250		
B35D	0..350		
B04C	0..400		
B05C	0..500		
B06C	0..600		
B07C	0..700		
B01M	0..1000		

Ex.: **TPF - G - V - B02C**

Transducer: output signal 3 mV/V, pressure fitting M18x1.5 flush diaphragm, pressure range 200 bar, 6-pole Veam connector

Ex.: **TPF - G - V - B01D - EX**

Transducer: output signal 1.5 mV/V, pressure fitting M18x1.5 flush diaphragm, pressure range 10 bar, 6-pole Veam connector, explosion-proof version

GEFRAN spa reserves the right to make any kind of design or functional modification at any moment without prior notice



LEADER Electronic Co., Ltd
 116, Jianghuali, Jianghua Road, Jiangmen City, GD, PRC
 Tel: + 86 750 3101711, 3379183
 Fax: + 86 750 3388669
 Website: www.leadersensors.com
 E-mail: leader@leadersensors.com



cod. 85921 -11/01