

FEATURES

- STACKED METALLIZED POLYETHYLENE NAPHTHALATE (PEN) FILM
- STANDARD EIA 1206, 1210, 1913, 2416, 2820, 3022 AND 3925 SIZES
- WIDE TEMPERATURE RANGE UP TO +105°C (16Vdc & 50Vdc)
- HIGH HEAT AND MOISTURE RESISTANT
- VERY STABLE TEMPERATURE, FREQUENCY, VOLTAGE, BIAS AND DIELECTRIC ABSORPTION CHARACTERISTICS
- SUITABLE FOR REFLAWSOLDERING
- TAPE AND REEL PACKAGING



**NSWC IS
RECOMMENDED
FOR NEW DESIGNS**



SURFACE MOUNT

SPECIFICATIONS	Case Sizes						
	1206	1210	1913	2416	2820	3022	3925
Capacitance Range	0.001 ~ 0.0047 μ F	0.0056 ~ 0.01 μ F	0.012 ~ 0.22 μ F	0.1 ~ 0.47 μ F	0.18 ~ 0.33 μ F	0.39 ~ .47 μ F	0.56 ~ 1.0 μ F
Voltage Ratings	16Vdc, 50Vdc, 100Vdc						
Capacitance Tolerance	\pm 10% (K) and \pm 5% (J)						
Temperature Range	-55°C ~ +105°C (16Vdc and 50Vdc), -55°C ~ +85°C (100Vdc)						
Dissipation Factor (20°C)	1.0% max @ 1 KHz						
Insulation Resistance (20°C)	3 Gigohms or 1000 Ω /F whichever is lower (16Vdc parts measured at 10Vdc)						
Dielectric Withstanding Voltage	150% of Rated Voltage 60 Seconds 175% of Rated Voltage for 5 Seconds (except 100Vdc parts)						
Temperature Characteristic	\pm 3% Δ C Maximum Over Temperature Range						
Dielectric Absorption	0.05 ~ 0.10% Typical						

ENVIRONMENTAL CHARACTERISTICS

Life Test At +105°C 1000 Hours at 125% of Rated Voltage (85°C for 100Vdc)	Capacitance Change	Within \pm 1% /-6% of Initial Value
	Dissipation Factor	1.1% Maximum
	Insulation Resistance	1 Gig Ω Minimum or 300 Ω /F whichever is lower
Resistance to Soldering Heat: +240°C Peak for 5 Seconds (+230°C for 100Vdc)	Capacitance Change	Within \pm 3% of Initial Value
	Dissipation Factor	1.1% Maximum
	Insulation Resistance	1 Gig Ω Minimum or 300 Ω /F whichever is lower
Humidity Load Life (90 ~ 95% RH) (1) 1000 Hours, +40°C (500 Hours for 100Vdc) (2) 500 Hours, +60°C	Capacitance Change	(1) +8%/-5%, (2) \pm 10%
	Dissipation Factor	(1) \pm 1.5%, (2) \pm 2%
	Insulation Resistance	(1) 100 Meg Ω or 30 Ω /F (2) 10Meg Ω or 3 Ω /F whichever is lower
Solderability with 10% Wt Rosin-Methanol Flux	90% Minimum Coverage After 5 Second Dip into 235°C Solder Pot	

RECOMMENDED SOLDERING PROFILES

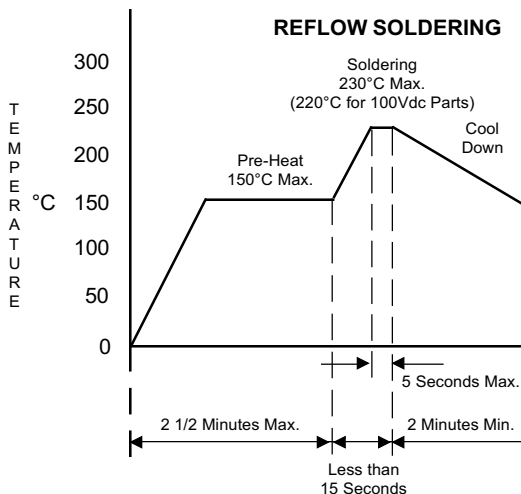

RECOMMENDED LAND PATTERN (mm)

EIA Size	A	B	C
1206	1.8	3.6	1.4
1210	1.8	3.6	2.3
1913	2.6	6.6	3.0
2416	3.8	7.8	3.8
2820	4.5	9.0	4.6
3022	5.1	9.7	5.0
3925	7.2	11.9	5.7

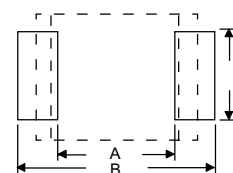

STANDARD PRODUCTS AND SIZE CODE

Cap.	Code	Working Voltage (Vdc)		
		16	50	100
0.0010	102			B2
0.0012	122			B2
0.0015	152			B2
0.0018	182			B2
0.0022	222			B2
0.0027	272			B2
0.0033	332			B3
0.0039	392			B3
0.0047	472			B3
0.0056	562			C2
0.0068	682			C2
0.0082	822			C3
0.010	103			C3
0.012	123			D1
0.015	153			D1
0.018	183			D1
0.022	223			D1
0.027	273			D1
0.033	333			D1
0.039	393			D1
0.047	473			D2
0.056	563		D2	D2
0.068	683		D2	D3
0.082	823		D3	D4
0.1	104		D4	E1
0.12	124	D1	E1	E3
0.15	154	D2	E2	E4
0.18	184	D2	E3	G1
0.22	224	D3	E4	G2
0.27	274	E1		G3
0.33	334	E2		G5
0.39	394	E3		Q1
0.47	474	E4		Q2
0.56	564			R1
0.68	684			R3
0.82	824			R6
1.0	105			R8*

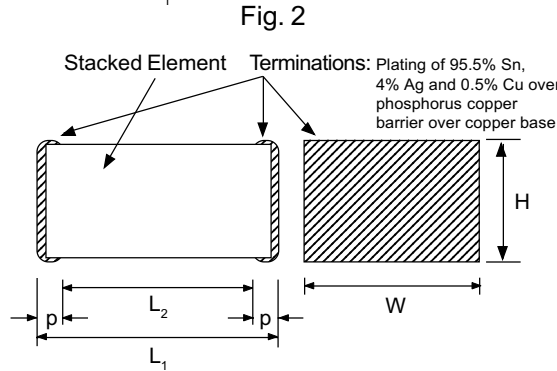
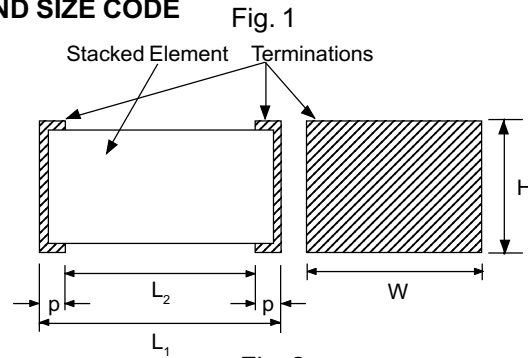

DIMENSION (mm) AND CASE CODE

Case Code	Length L ± 0.2	Width W	Height H ± 0.3	p	EIA Code	
B2	3.2	1.6	1.1	0.65 ± 0.3 (Fig. 1)	1206	
B3			1.5			
C2		2.5	1.5			1210
C3			2.1			
D1	4.8	3.3 ± 0.3	1.4	0.35 ± 0.2 (Fig. 2)	1913	
D2			2.0			
D3			2.4			
D4			2.8			
E1	6.0	4.1 ± 0.3	1.8			2416
E2			2.0			
E3			2.4			
E4			2.8			
G1	7.1	5.0 ± 0.4	2.0	2820		
G2			2.4			
G3			2.9			
G5			3.5			
Q1	7.7	5.5 ± 0.4	3.4	3022		
Q2			4.0			
R1	9.8	6.3 ± 0.4	3.0		3925	
R3			3.6			
R6			4.3			
R8			5.1			

PART NUMBERING SYSTEM

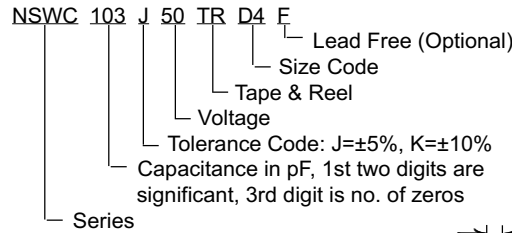

EMBOSED PLASTIC CARRIER

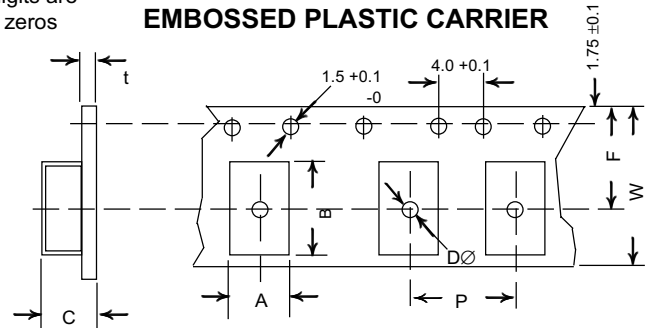

*ONLY AVAILABLE IN 10% TOLERANCE ONLY

TAPE DIMENSIONS (mm)

Case Code	A ± 0.1	B ± 0.1	C ± 0.2	t	W ± 0.3	F	P ± 0.1	D $+0.2/-0$				
B2	1.9	3.5	1.5	0.25	8	3.5	4	1.0				
B3			1.9									
C2	2.8		1.9									
C3			2.5									
D1	3.8	5.1	2.0	0.3 ± 0.05	12.0	5.5 ± 0.05	8.0	1.5				
D2			2.6									
D3, D4			3.4									
E1, E2	4.6	6.3	2.7					0.343 ± 0.013	16.0	7.5 ± 0.1	12.0	1.5
E3, E4			3.5									
G1 ~ G5	5.5	7.5	4.7									
Q1, Q2	6.91	8.43	5.685									
R1 ~ R8	8.94	10.54	5.795									

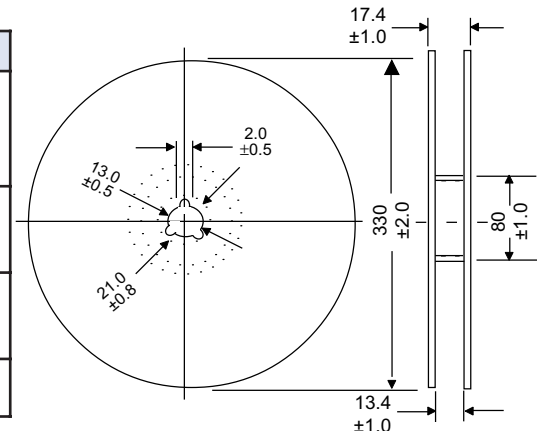

FEATURES

- STACKED METALLIZED POLYETHYLENE NAPHTHALATE (PEN) FILM
- STANDARD EIA 1913, 2416, 2420, 2820, 2825, 3022, 3925 AND 3925 SIZES
- HIGH HEAT AND MOISTURE RESISTANT
- VERY STABLE TEMPERATURE, FREQUENCY, VOLTAGE, BIAS AND DIELECTRIC ABSORPTION CHARACTERISTICS
- SUITABLE FOR REFLOW SOLDERING
- TAPE AND REEL PACKAGING



**NSWC IS
RECOMMENDED
FOR NEW DESIGNS**



SURFACE MOUNT

SPECIFICATIONS	Case Sizes						
	1913	2416	2420	2820	2825	3925	3932
Capacitance Range	0.001 μ F ~ 0.015 μ F	0.012 μ F ~ 0.068 μ F	0.027 μ F ~ 0.12 μ F	0.039 μ F ~ 0.047 μ F	0.056 μ F ~ 0.068 μ F	0.082 μ F ~ 0.1 μ F	0.12 μ F ~ 0.15 μ F
Voltage Ratings	250VDC, 400VDC						
Capacitance Tolerance	\pm 5% (J)						
Temperature Range	-55°C ~ +85°C						
Dissipation Factor (20°C)	1.0% max @ 1 KHz						
Insulation Resistance (20°C) (through 2K ohm resistor)	3 Gigohms @ 100VDC						
Dielectric Withstanding Voltage	1.5 times rated voltage						
Temperature Characteristic	\pm 3% Δ C Maximum Over Temperature Range						
Dielectric Absorption	0.05 ~ 0.10% Typical						

ENVIRONMENTAL CHARACTERISTICS

Life Test At +85°C 1000 Hours at 125% of Rated Voltage	Capacitance Change	Within \pm 1% / -6% of Initial Value
	Dissipation Factor	1.1% Maximum
	Insulation Resistance	1 Gig Ω Minimum
Resistance to Soldering Heat: +240°C Peak for 5 Seconds (+230°C for 100Vdc)	Capacitance Change	Within \pm 3% of Initial Value
	Dissipation Factor	1.1% Maximum
	Insulation Resistance	1 Gig Ω Minimum or 300 Ω /F whichever is lower
Humidity Load Life (90 ~ 95% RH) (1) 1000 Hours, +40°C	Capacitance Change	(1) +8%/-5%, (2) \pm 10%
	Dissipation Factor	(1) \pm 1.5%, (2) \pm 2%
	Insulation Resistance	100 MegW
Resistance to Soldering Heat 230°C \pm 3°C Soldering Iron: 30 W 250°C for 3.5 Sec.	Capacitance Change	Within \pm 5%
	Dissipation Factor	Maximum 1.1%
	Insulation Resistance	1 Gig Ω
Solderability with 10% Wt Rosin-Methanol Flux	95% Minimum Coverage After 5 Second Dip into 235°C Solder Pot	

RECOMMENDED SOLDERING PROFILES

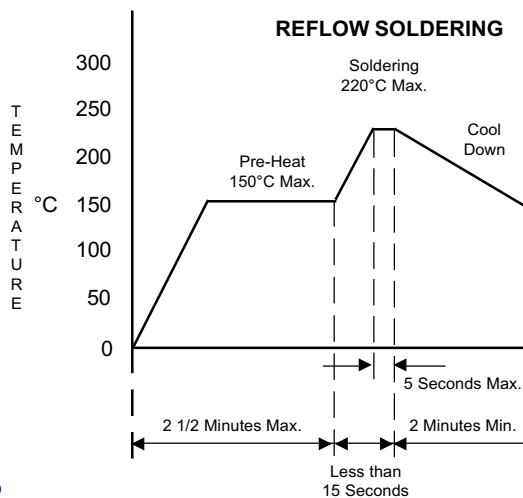

RECOMMENDED LAND PATTERN (mm)

EIA Size	A	B	C
1913	2.6	6.6	3.0
2416	3.8	7.8	3.8
2420	3.8	7.8	4.6
2820	4.5	9.0	4.6
2825	4.5	9.0	5.7
3925	7.2	11.9	5.7
3932	7.2	11.9	7.2

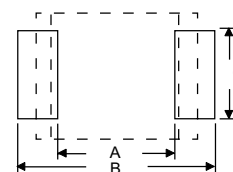

STANDARD PRODUCTS AND SIZE CODE

Cap.	Code	Working Voltage (Vdc)	
		250	400
0.0010	102	D1	D1
0.0012	122	D1	D1
0.0015	152	D1	D1
0.0022	222	D1	D1
0.0027	272	D1	D1
0.0033	332	D1	D1
0.0039	392	D1	D1
0.0047	472	D1	D1
0.0056	562	D1	D2
0.0068	682	D1	D2
0.0082	822	D1	D3
0.010	103	D1	D4
0.012	123	D1	E2
0.015	153	D1	E3
0.018	183	D2	E4
0.022	223	D2	E5
0.027	273	D3	F1
0.033	333	D4	F3
0.039	393	E2	G4
0.047	473	E3	G6
0.056	563	E4	H3
0.068	683	E5	H5
0.082	823	F2	R2
0.10	104	F4	R5
0.12	124	F5	S1
0.15	154	-	S3

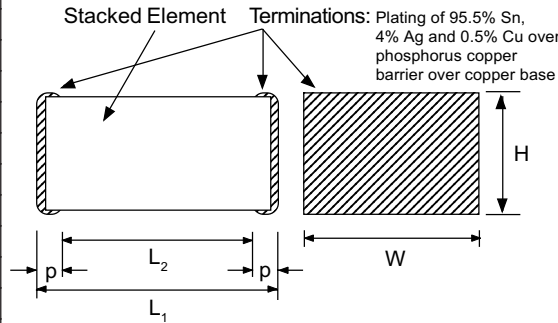

DIMENSION (mm) AND CASE CODE

Case Code	Length L ±0.2	Width W	Height H ±0.3	p	EIA Code	
D1	4.8	3.3 ± 0.3	1.4	0.35 ±0.2	1913	
D2			2.0			
D3			2.4			
D4			2.8			
E2	6.0	4.1 ± 0.3	2.0			2416
E3			2.4			
E4			2.8			
E5			3.2			
F1			3.0			
F2	3.2					
F3	6.0	5.0 ± 0.4	3.6			2420
F4			3.8			
F5			4.5			
G4	7.1	5.0 ± 0.4	3.2	2820		
G6			3.8			
H3	7.1	6.3 ± 0.4	3.6	2825		
H5			4.4			
R2			3.4			
R5	9.8	6.3 ± 0.4	4.0	3925		
S1			4.3			
S3			5.1		3932	

PART NUMBERING SYSTEM

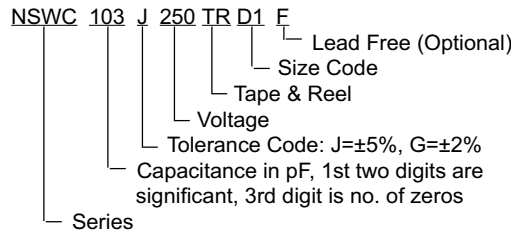

TAPE DIMENSIONS (mm)

Case Code	A±0.1	B±0.1	C±0.2	t	W±0.3	F	P±0.1	D+0.2/-0									
D1	3.8	5.1	2.0	0.3±0.05	12.0	5.5±0.05	8.0	1.5									
D2			2.6														
D3, D4			3.4														
E1, E2			2.7														
E3, E4	6.3	3.5	0.343±0.013					16.0	7.5±0.1	12.0	1.5						
E5		4.6															
F1 ~ F5		4.7															
G4, G6	7.5	5.1										0.343±0.013	16.0	7.5±0.1	12.0	1.5	
H3, H5		8.43															5.685
R2, R5	8.94	10.54															5.795
S1, S3																	5.795

EMBOSSED PLASTIC CARRIER

