

---

# HD74LV05A

Hex Inverters with Open Drain Outputs

# HITACHI

ADE-205-249 (Z)  
1st Edition  
March 1999

---

## Description

The HD74LV05A has six inverters with open drain outputs in a 14-pin package.

Low-voltage and high-speed operation is suitable for the battery-powered products (e.g., notebook computers), and the low-power consumption extends the battery life.

## Features

- $V_{CC} = 2.0\text{ V}$  to  $5.5\text{ V}$  operation
- All inputs  $V_{IH}$  (Max.) =  $5.5\text{ V}$  (@  $V_{CC} = 0\text{ V}$  to  $5.5\text{ V}$ )
- All outputs  $V_O$  (Max.) =  $5.5\text{ V}$  (@  $V_{CC} = 0\text{ V}$ )
- Typical  $V_{OL}$  ground bounce <  $0.8\text{ V}$  (@  $V_{CC} = 3.3\text{ V}$ ,  $T_a = 25^\circ\text{C}$ )
- Typical  $V_{OH}$  undershoot >  $2.3\text{ V}$  (@  $V_{CC} = 3.3\text{ V}$ ,  $T_a = 25^\circ\text{C}$ )
- Output current  $\pm 6\text{ mA}$  (@  $V_{CC} = 3.0\text{ V}$  to  $3.6\text{ V}$ ),  $\pm 12\text{ mA}$  (@  $V_{CC} = 4.5\text{ V}$  to  $5.5\text{ V}$ )

## Function Table

Input A	Output Y
L	H
H	L

Note: H:High level

L:Low level

# HD74LV05A

## Pin Arrangement

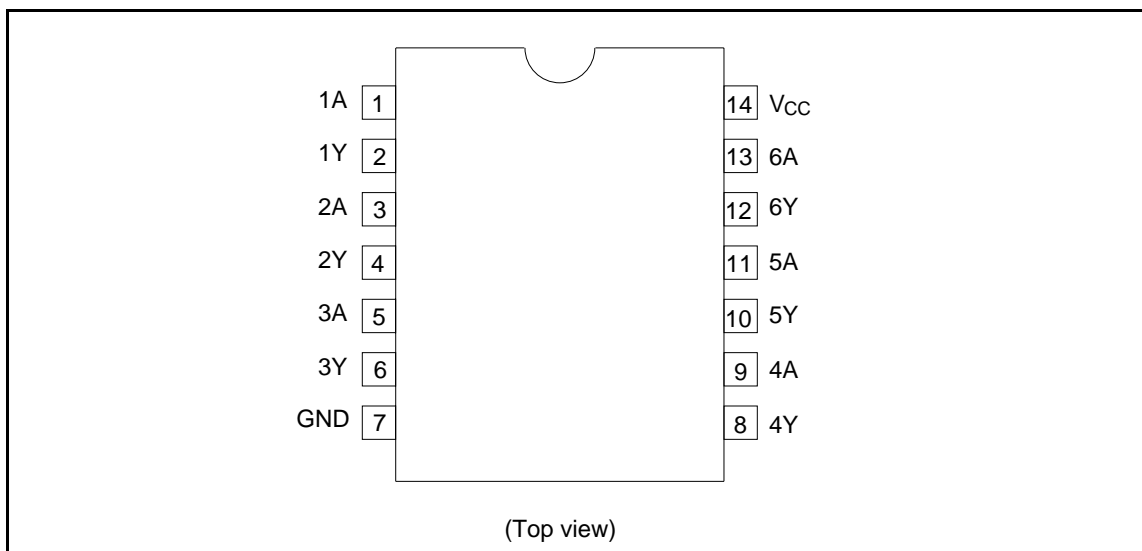

## Absolute Maximum Ratings

Item	Symbol	Ratings	Unit	Conditions
Supply voltage range	$V_{CC}$	-0.5 to 7.0	V	
Input voltage range*1	$V_I$	-0.5 to 7.0	V	
Output voltage range*1, 2	$V_O$	-0.5 to $V_{CC} + 0.5$ -0.5 to 7.0	V	Output: H or L $V_{CC}$ : OFF
Input clamp current	$I_{IK}$	-20	mA	$V_I < 0$
Output clamp current	$I_{OK}$	$\pm 50$	mA	$V_O < 0$ or $V_O > V_{CC}$
Continuous output current	$I_O$	$\pm 25$	mA	$V_O = 0$ to $V_{CC}$
Continuous current through $V_{CC}$ or GND	$I_{CC}$ or $I_{GND}$	$\pm 50$	mA	
Maximum power dissipation at $P_T$ $T_a = 25^\circ\text{C}$ (in still air)*3		785 500	mW	SOP TSSOP
Storage temperature	$T_{stg}$	-65 to 150	$^\circ\text{C}$	

Notes: The absolute maximum ratings are values which must not individually be exceeded, and furthermore, no two of which may be realized at the same time..

1.The input and output voltage ratings may be exceeded if the input and output clamp-current ratings are observed.

2.This value is limited to 5.5 V maximum.

3.The maximum package power dissipation was calculated using a junction temperature of 150 $^\circ\text{C}$ .

**Recommended Operating Conditions**

Item	Symbol	Min	Max	Unit	Conditions
Supply voltage range	$V_{CC}$	2.0	5.5	V	
Input voltage range	$V_I$	0	5.5	V	
Output voltage range	$V_O$	0	5.5	V	
Output current	$I_{OL}$	—	50	$\mu A$	$V_{CC} = 2.0 V$
		—	2	mA	$V_{CC} = 2.3 \text{ to } 2.7 V$
		—	6		$V_{CC} = 3.0 \text{ to } 3.6 V$
		—	12		$V_{CC} = 4.5 \text{ to } 5.5 V$
Input transition rise or fall rate	$\Delta t/\Delta v$	0	200	ns/V	$V_{CC} = 2.3 \text{ to } 2.7 V$
		0	100		$V_{CC} = 3.0 \text{ to } 3.6 V$
		0	20		$V_{CC} = 4.5 \text{ to } 5.5 V$
Operating free-air temperature	$T_a$	-40	85	$^{\circ}C$	

Note: Unused or floating inputs must be held high or low.

**Logic Diagram**

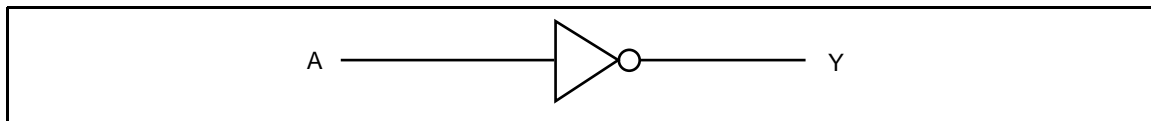

**DC Electrical Characteristics**

- $T_a = -40 \text{ to } 85^{\circ}C$
- 

Item	Symbol	$V_{CC} (V)^*$	Min	Typ	Max	Unit	Test Conditions
Input voltage	$V_{IH}$	2.0	1.5	—	—	V	
		2.3 to 2.7	$V_{CC} \times 0.7$	—	—		
		3.0 to 3.6	$V_{CC} \times 0.7$	—	—		
		4.5 to 5.5	$V_{CC} \times 0.7$	—	—		
	$V_{IL}$	2.0	—	—	0.5		
		2.3 to 2.7	—	—	$V_{CC} \times 0.3$		
		3.0 to 3.6	—	—	$V_{CC} \times 0.3$		
		4.5 to 5.5	—	—	$V_{CC} \times 0.3$		
Output voltage	$V_{OL}$	Min to Max	—	—	0.1	V	$I_{OL} = 50 \mu A$
		2.3	—	—	0.4		$I_{OL} = 2 \text{ mA}$
		3.0	—	—	0.44		$I_{OL} = 6 \text{ mA}$
		4.5	—	—	0.55		$I_{OL} = 12 \text{ mA}$
Input current	$I_{IN}$	0 to 5.5	—	—	$\pm 1$	$\mu A$	$V_{IN} = 5.5 V \text{ or } GND$

## HD74LV05A

Item	Symbol	V <sub>CC</sub> (V)*	Min	Typ	Max	Unit	Test Conditions
Quiescent supply current	I <sub>CC</sub>	5.5	—	—	20	μA	V <sub>IN</sub> = V <sub>CC</sub> or GND, I <sub>O</sub> = 0
Output leakage current	I <sub>OFF</sub>	0	—	—	5	μA	V <sub>O</sub> = 5.5 V
Input capacitance	C <sub>IN</sub>	3.3	—	2.3	—	pF	V <sub>I</sub> = V <sub>CC</sub> or GND

- Note: For conditions shown as Min or Max use the appropriate values under recommended operating conditions.

### Switching Characteristics

- V<sub>CC</sub> = 2.5 ± 0.2 V

•

T<sub>a</sub> = 25°C

T<sub>a</sub> = -40 to 85°C

Item	Symbol	Min	Typ	Max	Min	Max	Unit	Test Conditions	FROM (Input)	TO (Output)
Propagation delay	t <sub>PLH</sub>	—	4.7	10.4	1.0	13.0	ns	C <sub>L</sub> = 15 pF	A	Y
		—	9.5	15.2	1.0	18.0		C <sub>L</sub> = 50 pF		
time	t <sub>PHL</sub>	—	5.4	10.4	1.0	13.0		C <sub>L</sub> = 15 pF		
		—	7.9	15.2	1.0	18.0		C <sub>L</sub> = 50 pF		

- V<sub>CC</sub> = 3.3 ± 0.3 V

•

T<sub>a</sub> = 25°C

T<sub>a</sub> = -40 to 85°C

Item	Symbol	Min	Typ	Max	Min	Max	Unit	Test Conditions	FROM (Input)	TO (Output)
Propagation delay	t <sub>PLH</sub>	—	4.0	7.1	1.0	8.5	ns	C <sub>L</sub> = 15 pF	A	Y
		—	7.3	10.6	1.0	12.0		C <sub>L</sub> = 50 pF		
time	t <sub>PHL</sub>	—	4.3	7.1	1.0	8.5		C <sub>L</sub> = 15 pF		
		—	5.8	10.6	1.0	12.0		C <sub>L</sub> = 50 pF		

- $V_{CC} = 5.0 \pm 0.5 \text{ V}$

•

$T_a = 25^\circ\text{C}$

$T_a = -40 \text{ to } 85^\circ\text{C}$

Item	Symbol	Min	Typ	Max	Min	Max	Unit	Test Conditions	FROM (Input)	TO (Output)
Propagation delay	$t_{PLH}$	—	3.3	5.5	1.0	6.5	ns	$C_L = 15 \text{ pF}$	A	Y
		—	5.6	7.5	1.0	8.5		$C_L = 50 \text{ pF}$		
time	$t_{PHL}$	—	3.4	5.5	1.0	6.5		$C_L = 15 \text{ pF}$		
		—	4.1	7.5	1.0	8.5		$C_L = 50 \text{ pF}$		

### Operating Characteristics

- $C_L = 50 \text{ pF}$

•

$T_a = 25^\circ\text{C}$

Item	Symbol	$V_{CC} \text{ (V)}$	Min	Typ	Max	Unit	Test Conditions
Power dissipation capacitance	$C_{PD}$	3.3	—	9.6	—	pF	$f = 10 \text{ MHz}$
		5.0	—	11.4	—		

### Noise Characteristics

- $C_L = 50 \text{ pF}$

•

$T_a = 25^\circ\text{C}$

Item	Symbol	$V_{CC} \text{ (V)}$	Min	Typ	Max	Unit	Test Conditions
Quiet output, maximum dynamic $V_{OL}$	$V_{OL(P)}$	3.3	—	0.3	0.8	V	
Quiet output, minimum dynamic $V_{OL}$	$V_{OL(V)}$	3.3	—	-0.1	-0.8		
High-level dynamic input voltage	$V_{IH(D)}$	3.3	2.31	—	—	V	
Low-level dynamic input voltage	$V_{IL(D)}$	3.3	—	—	0.99		

# HD74LV05A

## Test Circuit

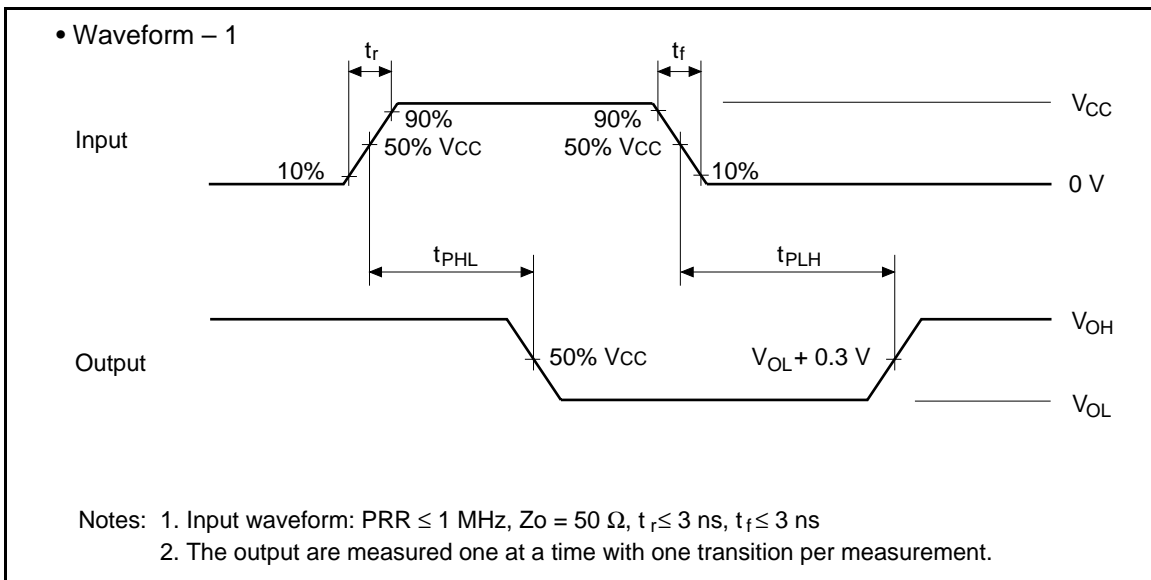
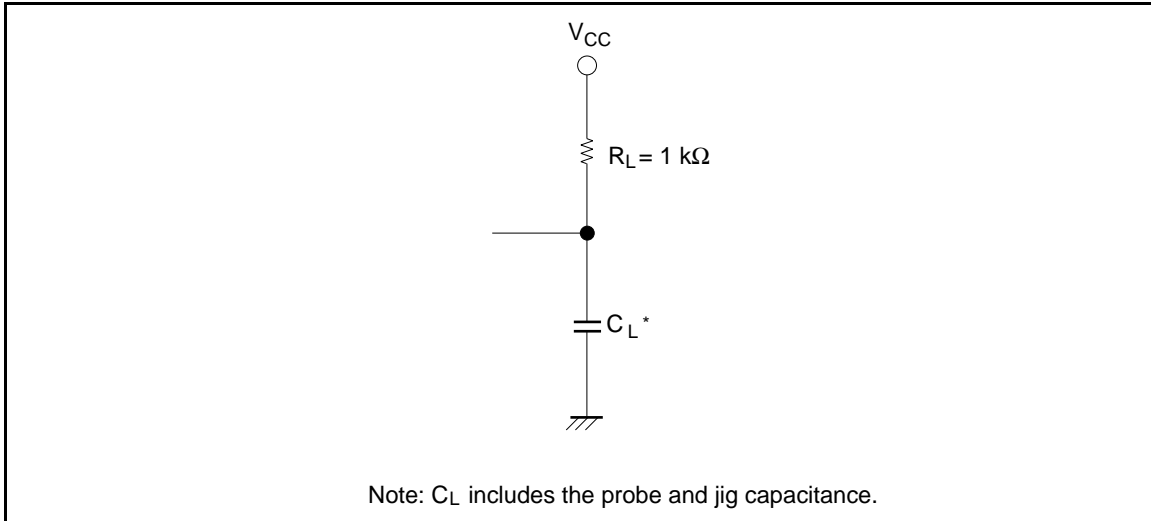

Package Dimensions

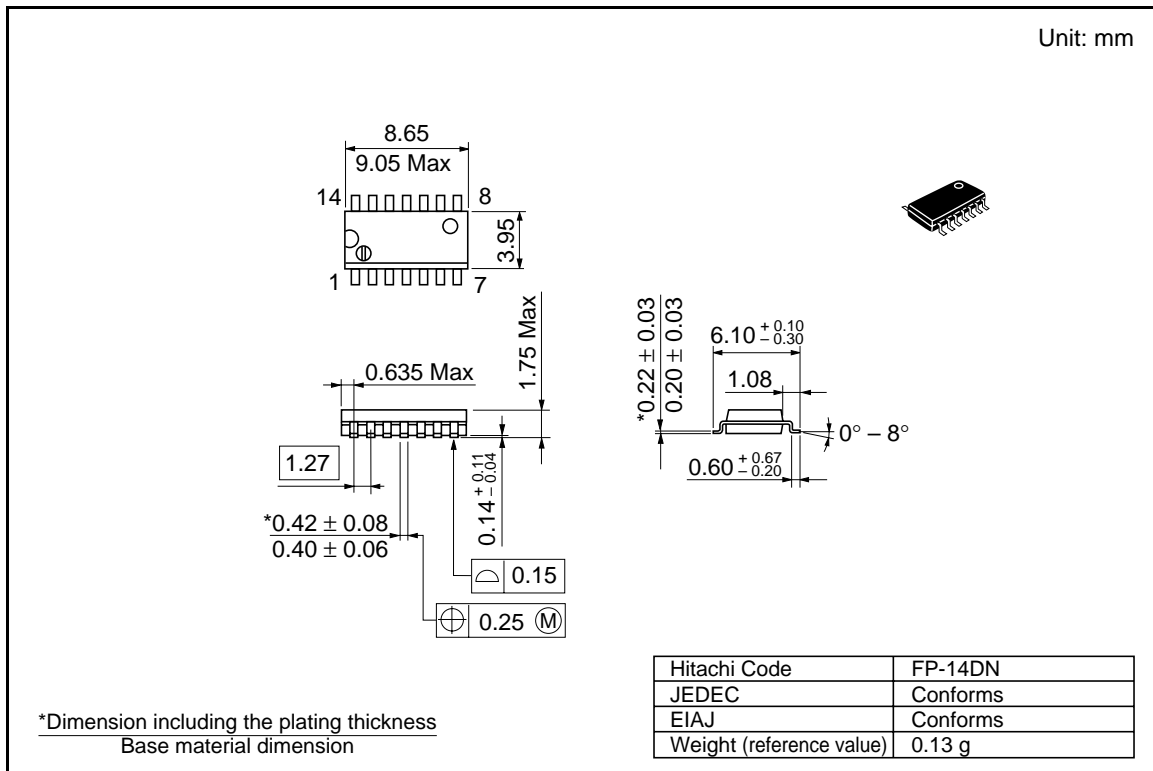
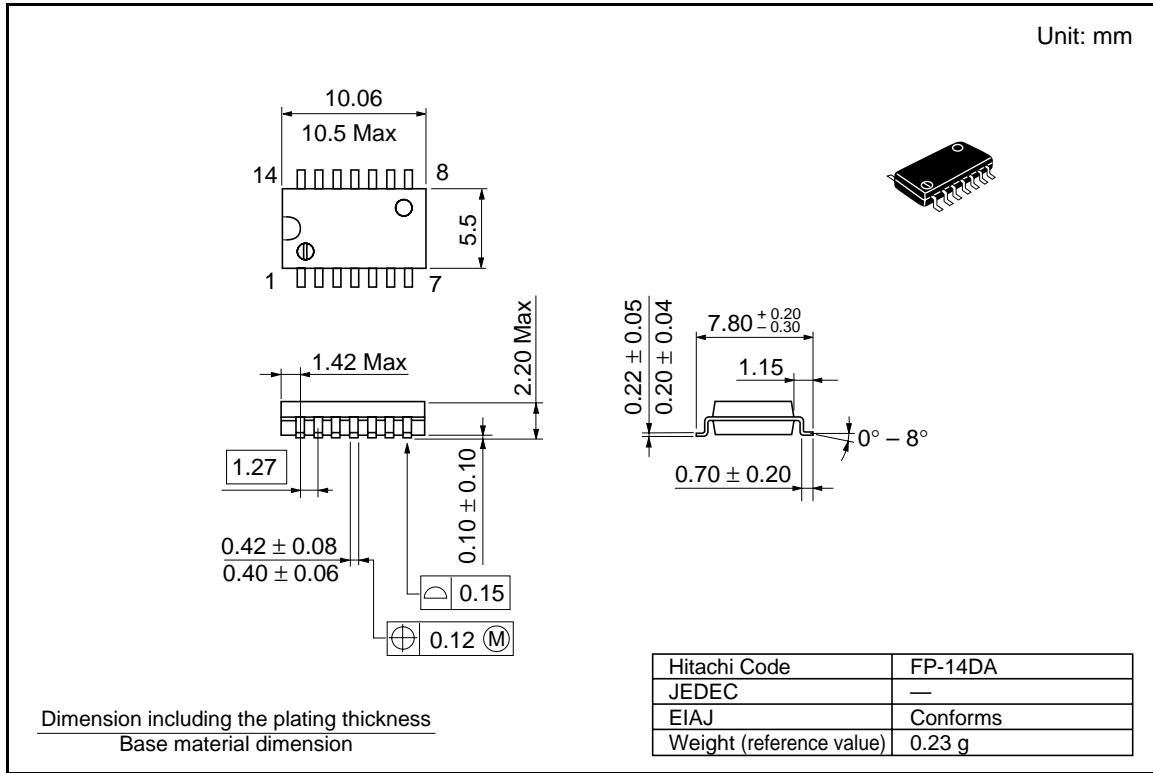

# HD74LV05A

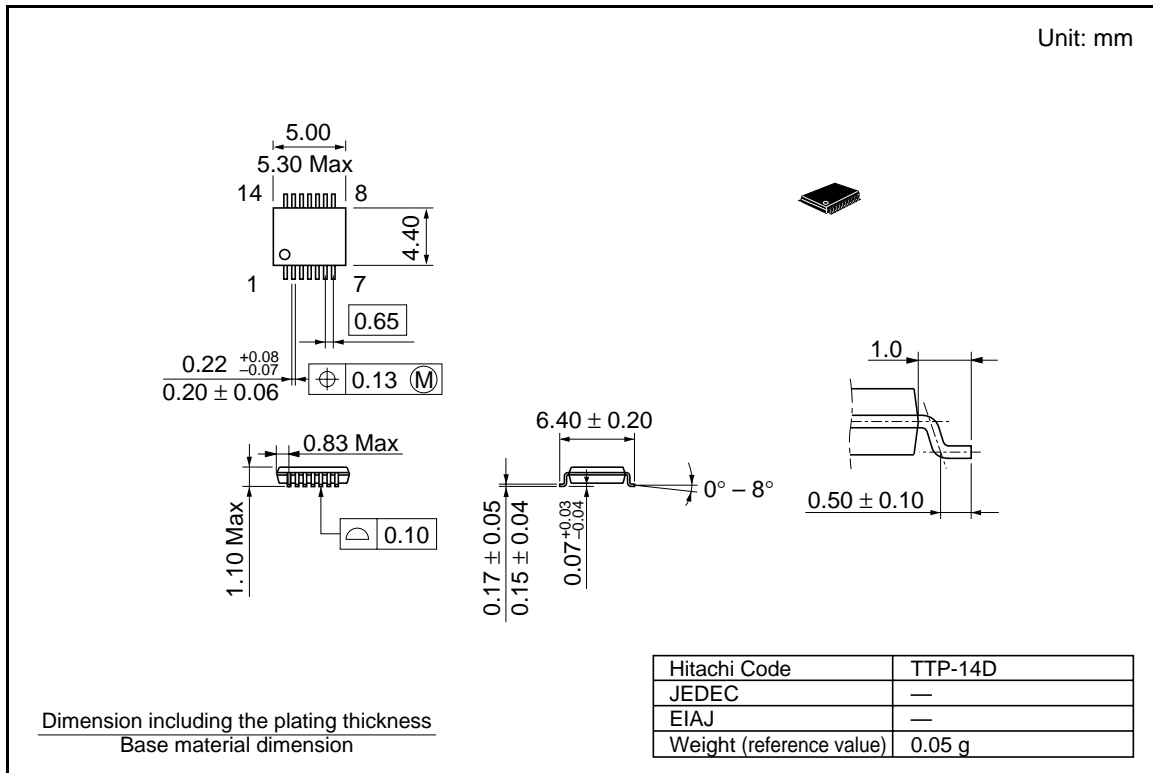

## Cautions

1. Hitachi neither warrants nor grants licenses of any rights of Hitachi's or any third party's patent, copyright, trademark, or other intellectual property rights for information contained in this document. Hitachi bears no responsibility for problems that may arise with third party's rights, including intellectual property rights, in connection with use of the information contained in this document.
2. Products and product specifications may be subject to change without notice. Confirm that you have received the latest product standards or specifications before final design, purchase or use.
3. Hitachi makes every attempt to ensure that its products are of high quality and reliability. However, contact Hitachi's sales office before using the product in an application that demands especially high quality and reliability or where its failure or malfunction may directly threaten human life or cause risk of bodily injury, such as in aerospace, aeronautics, nuclear power, combustion control, transportation, traffic, safety equipment or medical equipment for life support.
4. Design your application so that the product is used within the ranges guaranteed by Hitachi particularly for maximum rating, operating supply voltage range, heat radiation characteristics, installation conditions and other characteristics. Hitachi bears no responsibility for failure or damage when used beyond the guaranteed ranges. Even within the guaranteed ranges, consider normally foreseeable failure rates or failure modes in semiconductor devices and employ systemic measures such as fail-safe devices, so that the equipment incorporating the Hitachi product does not cause bodily injury, fire or other consequential damage due to operation of the Hitachi product.
5. This product is not designed to be radiation resistant.
6. No one is permitted to reproduce or duplicate, in any form, the whole or part of this document without written approval from Hitachi.
7. Contact Hitachi's sales office for any questions regarding this document or Hitachi semiconductor products.



# HITACHI

**Hitachi, Ltd.**

Semiconductor & IC Div.  
 Nippon Bldg., 2-6-2, Ohte-machi, Chiyoda-ku, Tokyo 100-0004, Japan  
 Tel: Tokyo (03) 3270-2111 Fax: (03) 3270-5109

URL      NorthAmerica      : <http://semiconductor.hitachi.com/>  
              Europe                : <http://www.hitachi-eu.com/hel/ecg>  
              Asia (Singapore)      : <http://www.has.hitachi.com.sg/grp3/sicd/index.htm>  
              Asia (Taiwan)            : [http://www.hitachi.com.tw/E/Product/SICD\\_Frame.htm](http://www.hitachi.com.tw/E/Product/SICD_Frame.htm)  
              Asia (HongKong)        : <http://www.hitachi.com.hk/eng/bo/grp3/index.htm>  
              Japan                        : <http://www.hitachi.co.jp/Sicd/indx.htm>

**For further information write to:**

Hitachi Semiconductor  
 (America) Inc.  
 179 East Tasman Drive,  
 San Jose, CA 95134  
 Tel: <1> (408) 433-1990  
 Fax: <1>(408) 433-0223

Hitachi Europe GmbH  
 Electronic components Group  
 Dornacher Straße 3  
 D-85622 Feldkirchen, Munich  
 Germany  
 Tel: <49> (89) 9 9180-0  
 Fax: <49> (89) 9 29 30 00

Hitachi Europe Ltd.  
 Electronic Components Group.  
 Whitebrook Park  
 Lower Cookham Road  
 Maidenhead  
 Berkshire SL6 8YA, United Kingdom  
 Tel: <44> (1628) 585000  
 Fax: <44> (1628) 778322

Hitachi Asia Pte. Ltd.  
 16 Collyer Quay #20-00  
 Hitachi Tower  
 Singapore 049318  
 Tel: 535-2100  
 Fax: 535-1533

Hitachi Asia Ltd.  
 Taipei Branch Office  
 3F, Hung Kuo Building, No.167,  
 Tun-Hwa North Road, Taipei (105)  
 Tel: <886> (2) 2718-3666  
 Fax: <886> (2) 2718-8180

Hitachi Asia (Hong Kong) Ltd.  
 Group III (Electronic Components)  
 7/F., North Tower, World Finance Centre,  
 Harbour City, Canton Road, Tsim Sha Tsui,  
 Kowloon, Hong Kong  
 Tel: <852> (2) 735 9218  
 Fax: <852> (2) 730 0281  
 Telex: 40815 HITEC HX

Copyright © Hitachi, Ltd., 1998. All rights reserved. Printed in Japan.