

Technical Data

HC-49/U (NMP / NYP) Series



Description

The HC-49/U Series is an industry standard AT-cut crystal housed in a Mil standard HC-49/U package.

Applications & Features

- AT-cut performance
- Resistance weld seal
- Clock/VCXO Multiplier
- Fibre Channel
- Ethernet
- 56K and Cable Modems
- ADSL
- ISDN
- Microcontrollers
- Remote Control Devices
- Network Processors
- Audio/Video

Frequency Range:	1.8432 MHz to 200 MHz
Temperature Range:	
Operating:	-20 to +70°C (standard - see part number builder for other options)
Storage:	-55 to +125°C

Temp. Stability Tolerance:	±50 ppm, -20 to +70°C (standard - see part number builder for other options)
-----------------------------------	--

Characteristics at 25°C ±2°C:	
Freq. Calibration Tolerance:	±30 ppm (standard - see part number builder for other options)
Load Capacitance:	12 pF to 32 pF or series resonance
Effective Series Resistance:	700 to 20 Ω (frequency dependent)
Drive Level:	100μW correlation, 2000μW max operating
Shunt Capacitance:	7pF max

Mechanical:	
Shock:	MIL-STD-883, Method 2002, Condition B
Solderability:	MIL-STD-883, Method 2003
Terminal Strength:	MIL-STD-202, Method 211, Conditions A and C
Vibration:	MIL-STD-883, Method 2007, Condition A
Solvent Resistance:	MIL-STD-202, Method 215
Resistance to Soldering Heat:	MIL-STD-202, Method 210, Condition B

Environmental:	
Gross Leak Test:	MIL-STD-883, Method 1014, Condition C
Fine Leak Test:	MIL-STD-883, Method 1014, Condition A
Thermal Shock:	MIL-STD-883, Method 1011, Condition A
Moisture Resistance:	MIL-STD-883, Method 1004

Part Numbering Guide

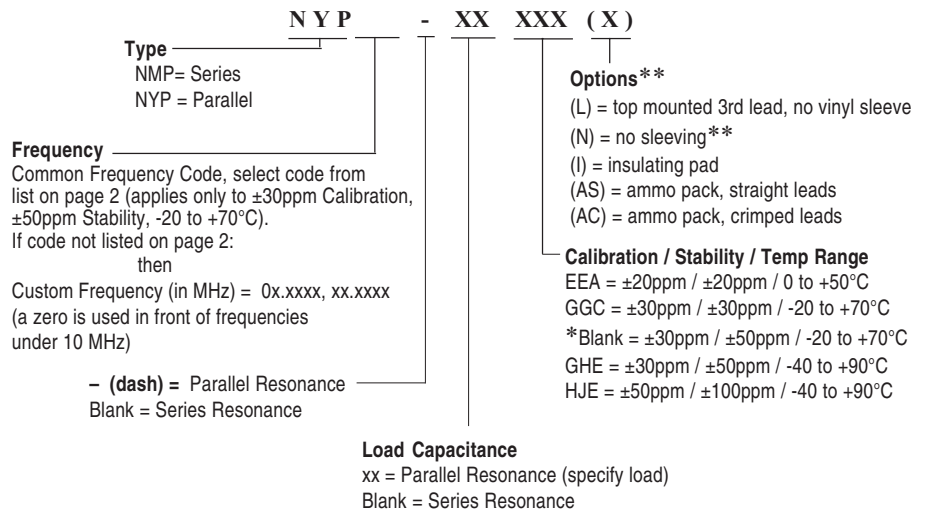

*no code used, as these specs designate standard configuration for this series
**Parts come covered with vinyl shrink sleeve as standard and are shipped bulk in bags.

Part Number Examples:
Spec: Common Freq 20MHz, ±30ppm calib, ±50ppm stab, -20 to +70°C, 12pF = NYP200-12
Spec: Custom Freq 5.1234MHz, ±30ppm calib, ±30ppm stab, -20 to +70°C, 16pF = NYP05.1234-16GGC

Technical Data

HC-49/U (NMP / NYP) Series

Package Details

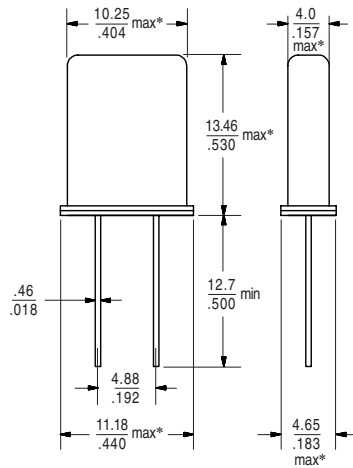

*Maximum dimensions include vinyl sleeve

Scale: None (Dimensions in $\frac{mm}{inches}$)

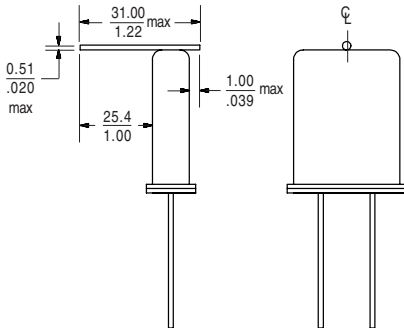

Optional 3rd Lead (no vinyl sleeving)

Marking Format (exact location of items may vary)

Products with custom frequency, calibration, stability, temp:

Line 1: SaRonix
 Line 2: Frequency (up to 9 digits, including decimal point)
 Line 3: Calib/Stability/Temp Code - Load Capacitance (marked "S" for Series Resonance)
 Line 4: Date Code: YYWW

SARONIX
xx.xxxxxx
GGC - 12
YYWW

Products with common frequency and standard specifications:

Line 1: SaRonix
 Line 2: Frequency (up to 9 digits, including decimal point)
 Line 3: NMP (for Series) or NYP (for Parallel), Frequency Code
 - Load Capacitance (marked "S" for Series Resonance)
 Line 4: Date Code: YYWW

SARONIX
xx.xxxxxx
NMPxxx - S
YYWW

Common Frequencies

Common frequency codes:
 to be used only with ± 30 ppm calibration, ± 50 ppm stability over -20 to $+70^\circ\text{C}$

Frequency MHz	Frequency Code	Maximum ESR (Fundamental)
1.843200	018A	700
2.000000	020A	500
2.097425	021A	500
2.457600	024A	300
3.000000	030A	200
3.276800	032A	150
3.579545	035A	150
3.600000	036	150
3.686400	037	120
3.932160	039	120
4.000000	040	100
4.096000	0409	100
4.194304	041	100
4.433619	044	80
4.915200	049	55
5.000000	050	50
5.068800	051	50
5.185000	052	50
5.714300	057	50
6.000000	060	50
6.144000	061	40
6.553600	065	40
7.000000	070	40
7.159090	071	40
7.372800	073	40
8.000000	080	35
8.192000	081	35
9.216000	092	35
9.830400	098	35
10.000000	100	30
10.738635	107	30
11.000000	110	30
11.059200	111	30
12.000000	120	30
12.288000	122	30
14.318180	143	25
14.745600	147	25
15.000000	150	25
16.000000	160	25
16.384000	163	25
18.000000	180	20
18.432000	184	20
19.660800	196	20
20.000000	200	20
22.118400	221	20
24.000000	240	20
24.576000	245	40 (3rd OT)
25.000000	250	40 (3rd OT)
27.000000	270	40 (3rd OT)
28.636360	286	40 (3rd OT)
30.000000	300	25
32.000000	320	40 (3rd OT)
36.000000	360	40 (3rd OT)
40.000000	400	40 (3rd OT)
48.000000	480	40 (3rd OT)

All specifications are subject to change without notice.

DS-121 REV D04