



**BVU-3K0W14-B**

**PACKAGE CONFIGURATION**

**DESCRIPTION**

Dice Material : GaN Blue  
Light Color : White Color  
Lens Color : Water Transparent  
Stand-Off P/N : BVU-3K0W14-B R



**RADIATION PATTERN**

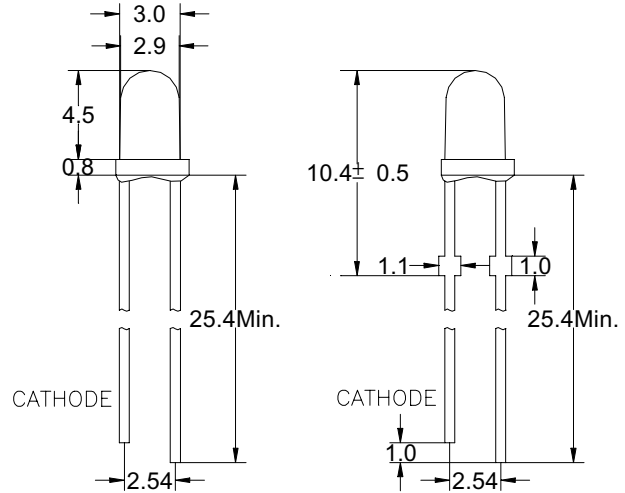
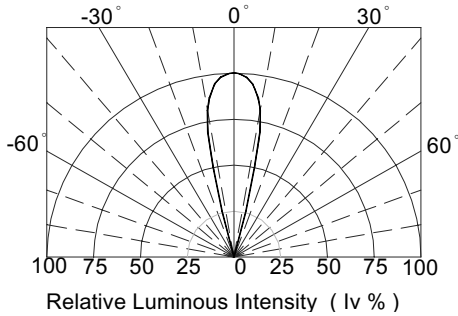

**ABSOLUTE MAXIMUM RATINGS AT Ta = 25 °C**

Tolerance ± 0.25 mm

PARAMETER	MAX.	UNIT
Power Dissipation	120	mW
Continuous Forward Current	30	mA
Peak Forward Current ( 1/10 Duty Cycle , 0.1ms Pulse Width )	100	mA
Reverse Voltage	5	V
Derating Linear From 50 °C	0.4	mA/°C
Operating Temperature Range	-40 to + 100	°C
Storage Temperature Range	-40 to + 100	°C
Lead Solder Temperature 1.6 mm Below Package	260 °C for 5 seconds	

**ELECTRICAL / OPTICAL CHARACTERISTICS AT Ta = 25 °C**

SYMBOL	PARAMETER	TEST COND.	MIN.	TYP.	MAX.	UNIT
V <sub>F</sub>	Forward Voltage	I <sub>F</sub> = 20 mA		3.4	4	V
I <sub>R</sub>	Reverse Current	V <sub>R</sub> = 5V			2	μA
2θ 1/2	Viewing Angle	I <sub>F</sub> = 20 mA		25		Deg

**BIN GRADE LIMITS ( I F = 20 mA ) CHROMATICITY COORDINATES**

WA	x	0.26	0.26	0.29	0.29	WC	x	0.32	0.32	0.35	0.35
	y	0.19	0.23	0.27	0.23		y	0.28	0.32	0.35	0.31
WB	x	0.29	0.29	0.32	0.32	WD	x	0.35	0.35	0.38	0.38
	y	0.23	0.27	0.32	0.28		y	0.31	0.35	0.4	0.36

One delivery will include three different ranks of products.

Measurement Uncertainty of the color coordinates : ±0.02

**BIN GRADE LIMITS ( I F = 20 mA ) LUMINOUS INTENSITY / mcd**

Bin	J	K	L	M	N	O
Min.	1000	1300	1680	2180	2800	3600
Max.	1300	1680	2180	2800	3600	4650

One delivery will include the consecutive two ranks of products.

Measurement Uncertainty of the Luminous Intensity : ± 15 %

\*Bright View reserves the rights to alter specifications and remove availability of products at any time without notice.

\*These products are sensitive to static electricity.

Caution must be taken strictly to avoid static electricity.

\*Chromaticity Coordinates , x,y is according to CIE Chromaticity Diagram base on color of lamps.

\*θ 1/2 is the off-axis angle where the luminous intensity is one half the on-axis intensity.