

# ***OE HYBRID***

## ***622.08Mbps Transmitter***

### **OD-J8400-0B01**

**OC-12: LR-1**

**STM-4: L-4.1**

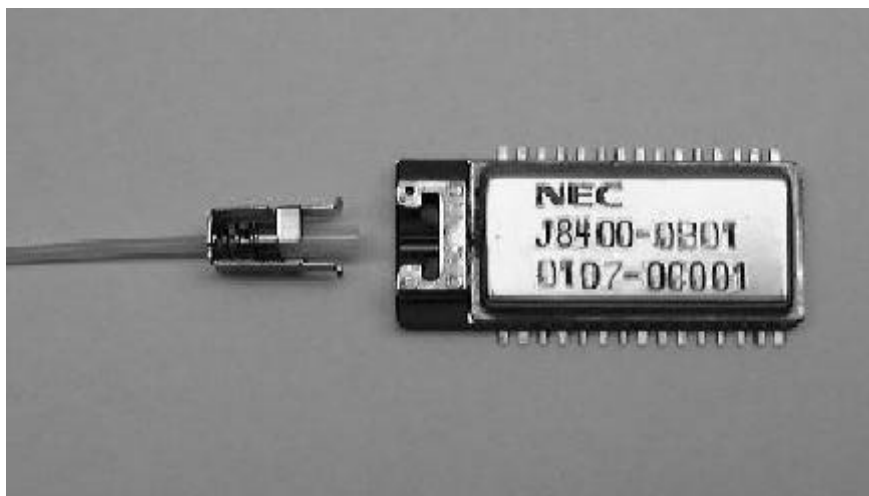

## - Contents -

<b>1. PRODUCT NUMBER</b> .....	<b>3</b>
<b>2. SPECIFICATIONS</b> .....	<b>3</b>
2.1 ABSOLUTE MAXIMUM RATINGS .....	3
2.2 ENVIRONMENTAL CONDITIONS.....	3
2.3 OPTICAL SIGNAL INTERFACE SPECIFICATIONS.....	4
2.4 ELECTRICAL SIGNAL INTERFACE SPECIFICATIONS.....	5
<b>3. FUNCTIONAL BLOCK DIAGRAM</b> .....	<b>7</b>
3.1 FUNCTIONAL BLOCK DIAGRAM.....	7
3.2 ALARM, MONITOR AND CONTROL FUNCTION .....	7
<b>4. RELIABILITY</b> .....	<b>8</b>
4.1 FIT NUMBER.....	8
4.2 RELIABILITY TEST ITEMS AND CONDITIONS.....	8
<b>5. PACKAGE SIZE, PIN ASSIGNMENT</b> .....	<b>9</b>
5.1 OUTLINE DIAGRAM, PIN LAYOUT .....	9
5.2 PIN ASSIGNMENT.....	10
<b>6. RECOMMENDED PERIPHERAL CIRCUIT</b> .....	<b>11</b>
<b>7. PAD LAYOUT</b> .....	<b>12</b>
<b>8. RECOMMENDED PATTERN LAYOUT</b> .....	<b>13</b>
<b>9. RECOMMENDED MOUNTING CONDITIONS</b> .....	<b>14</b>
9.1 MOUNT PROHIBITIVE AREA .....	14
9.2 RE-FLOW SOLDERING CONDITIONS.....	14
9.3 SOLVENT CLEANING.....	15
9.4 MOUNTING PRECAUTIONS.....	15
9.5 DE-SOLDERING FROM THE PRINTED BOARD .....	15
9.6 PIGTAIL ATTACHMENT.....	15
9.7 SHIPMENT PACKING.....	17
<b>10. APPLICATION PRECAUTIONS</b> .....	<b>18</b>

## 1. Product Number

Product Number	Specification	Operating Case Temperature
OD-J8400-0B01	SONET LR-1, and ITU-T G. 957 L-4.1 compliant	0 to +75 deg.C

Pigtail fiber cord is not included with the above product, it has to be separately ordered. The applicable pigtail fiber cords are listed below. Please refer to section 9.6 for connecting a pigtail cord to the above products.

Product Number	Connector Type	Fiber Cord Length
OD-S524-SC-SM	SC	51 to 55 cm
OD-S524-FCPC-SM	FC	
OD-S524-MUJ-SM	MUJ	
OD-S524-MU-SM	MU	

## 2. Specifications

### 2.1 Absolute Maximum Ratings

Parameter	Specification		Unit	Note
	Min	Max		
Supply Voltage (Vcc)	-0.3	+6.0	V	
Storage temperature	-40	+85	deg.C	
Signal Input Pins	0	Vcc	V	

### 2.2 Environmental Conditions

Parameter	Specification	Note
Data Rate	622.08 Mbps	
Data Format	Scrambled NRZ	Scrambler is not included.
Transmission Cable	Single-mode fiber	SI-10/125
Operating Case Temperature	0 to +75 deg.C	
Supply Voltage	+3.3V +/-5%	
Power Consumption	0.4 W (Typ)	Under condition at +25 deg.C, +3.30V
	0.6 W (Max)	Under condition at +75deg.C, +3.47V

## 2.3 Optical Signal Interface Specifications

Parameter	Specification		Unit	Note
	Min	Max		
Average Optical Output Power	-3	+2	dBm	
Extinction Ratio	13		dB	
RMS Spectral Width		1	nm	
RMS Center Wavelength	1280	1335	nm	
Optical Output Eye Diagram	ITU-T G.957 compliant			Refer to fig. 1
Laser Diode Classification	IEC 825-2 Class 1 compliant			
Optical Signal Polarity	Positive logic			

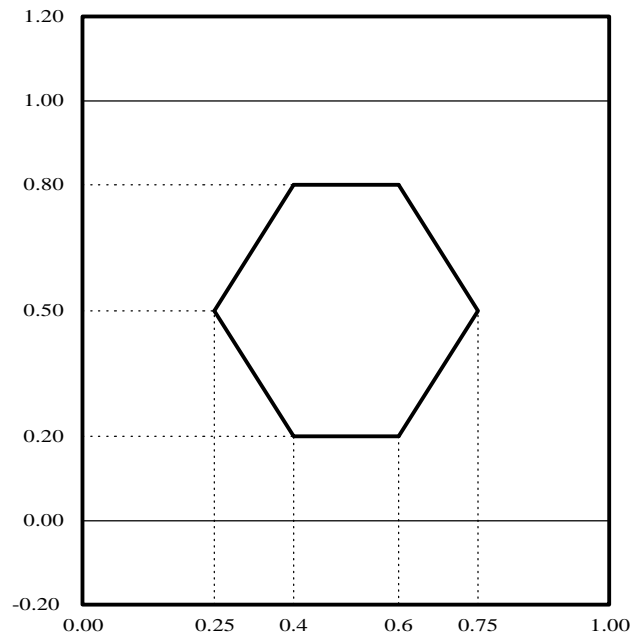

**Fig. 1** Optical output signal mask specifications of SONET/ITU standard specified by the waveform after passing through 4th order Bessel-filter which has cut-off frequency of  $622.08\text{MHz} \times 0.75$ .

## 2.4 Electrical Signal Interface Specifications

### 2.4.1 Data and Clock Input

Parameter	Specification		Unit
Input Signal Level		<b>Min</b>	<b>Max</b>
	VIH	Vcc-1.17	Vcc-0.81
	VIL	Vcc-1.84	Vcc-1.48
Data and Clock Signal	<p style="text-align: center;">tst, thd &gt; 200ps</p>		

### 2.4.2 Alarm Output (OPT OUT ALM, CURR ALM)

Parameter	Specification		Unit
Output Level		<b>Min</b>	<b>Max</b>
	VOH	0.9xVcc	Vcc
	VOL	0	0.1xVcc
Status	'L'	Fault condition	
	'H'	Normal operation	
Fan-out	IOH	-0.2	mA
	IOL	0.2	

### 2.4.3 Control input (SHUT DOWN)

Parameter	Specification		Unit
Input Level		<b>Min</b>	<b>Max</b>
	VIH	2.0	Vcc
	VIL	0	0.8
Status	'L'	Optical output disable	
	'H'	Optical output enable	

### 2.4.4 Control input (CURR ALM TST)

Parameter	Specification
Status	When CURR_ALM_TST is Connected to GND, CURR ALM will be asserted to 'L'. Leave open during normal operation.

## 2.4.5 Control Input (FF\_SEL)

Parameter	Specification
Status	When FF_SEL is Connected to GND, input data signal is retimed with input clock signal.
	When FF_SEL is left open, input data signal isn't retimed. CLK IN signals are not needed.

## 2.4.6 Performance Monitor

Parameter	Specification	Unit	Note
OPT MON	550 (Max)	mV	Voltage output. Please receive with high impedance (>1 M ohm) circuit.
BIAS MON	42 x Ib (Ib: Laser bias compensation current:[mA])	mV	Voltage output. Please receive with high impedance (>1 M ohm) circuit.

## 3. Functional Block Diagram

### 3.1 Functional Block Diagram

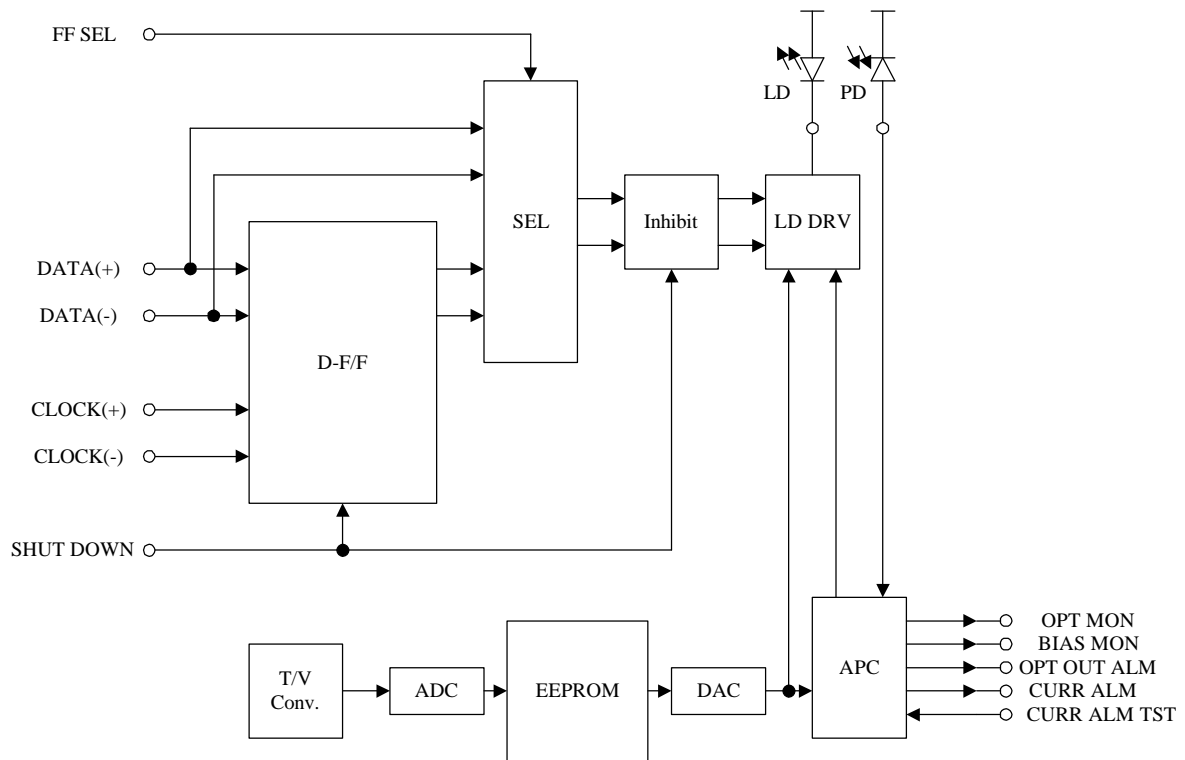

D-F/F: D-type flip-flop, LD DRV: Laser diode driver, DAC: Digital to analogue converter, T/V Conv.: Temperature to voltage converter, APC: Automatic power control circuit, ADC: Analogue to digital converter, EEPROM: Electronic erasable ROM, PD: PIN photo diode, LD: 1.31um laser diode

### 3.2 Alarm, Monitor and Control Function

Parameter	Symbol	Function
Optical output power loss alarm	OPT OUT ALM	To alert loss of power condition. Alarm does not assert until power degradation exceed 3 dB.
Laser degrade alarm	CURR ALM	To alert laser degradation. Alarm asserts when laser bias compensation current(Ib) increases by 25 mA +/- 5 mA from the initial value.
Laser shut down	SHUT DOWN	To shutdown laser output.
Current alarm test	CURR ALM TST	To test CURR ALM function. When connected to GND, CURR ALM is forced to active 'L'.
Laser bias current Monitor	BIAS MON	To monitor laser bias compensation current (Ib) . The Ib is calculated from output voltage (Vo) of this terminal; $I_b = V_o / 42 \text{ mA}$ . Initial value is nearly 0 V.
Optical output power monitor	OPT MON	To monitor the voltage that is proportional to optical launched power.

## 4. Reliability

### 4.1 FIT Number

TBD (to be determined)

### 4.2 Reliability Test Items and Conditions

<b>Item</b>	<b>Condition</b>
Accelerated aging	+85 deg.C, +3.465 V, 3000 hours
Temperature cycle	-40 to +85 deg.C, 4 h/cycle, 500 cycles
Damp heat	+85 deg.C, 85%RH, 500 hours
Vibration	10 to 55 Hz, 1.5 mm, 1 hour for x, y, z each direction
Mechanical shock	50 G, 11 ms, 3 times for x, y, z each direction
Thermal shock	0 and +100 deg.C in water, 5 minutes each temperature, 20 cycles
Low temperature storage	-40 deg.C, 2000 hours



## 5. Package size, Pin Assignment

### 5.1 Outline diagram, Pin layout

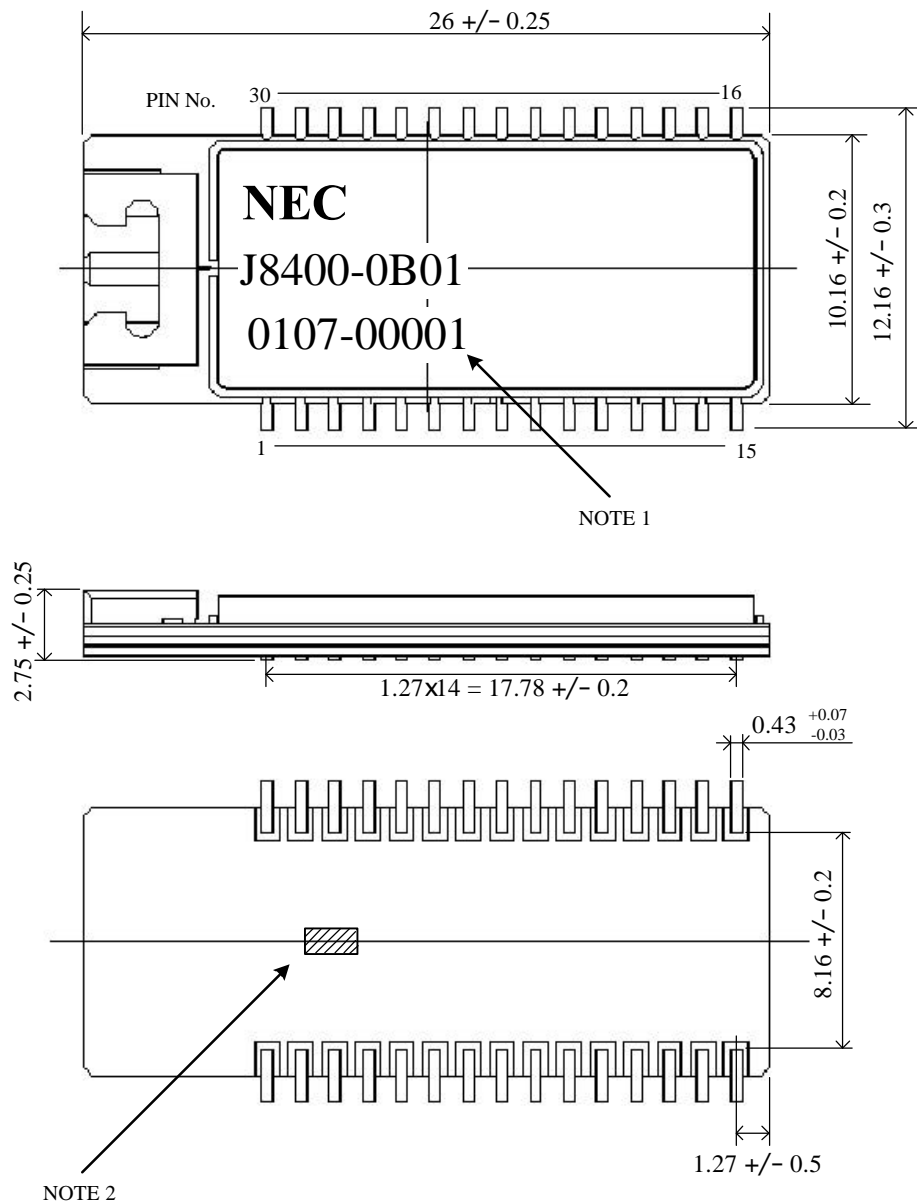

(Unit in mm)

Note1 Product name description is given below:

NEC:	NEC logo mark
J8400-0B01:	Product Number
****_****:	Production year/month-serial number

Note 2 Product testing terminal: Please keep open and don't connect to any other pattern or GND.

## 5.2 Pin Assignment

Pin No.	Symbol	I/O	Notes
1	OPT MON	O	Refer to page 6, 7
2	GND	I	
3	GND	I	
4	FF SEL	I	Refer to page 6, 7
5	GND	I	
6	CLK IN (-)	I	Refer to page 5, 7
7	CLK IN (+)	I	Refer to page 5, 7
8	GND	I	
9	DATA IN (-)	I	Refer to page 5, 7
10	DATA IN (+)	I	Refer to page 5, 7
11	SHUT DOWN	I	Refer to page 5, 7
12	BIAS MON	O	Refer to page 6, 7
13	CURR ALM TST	I	Refer to page 5, 7
14	CURR ALM	O	Refer to page 5, 7
15	OPT OUT ALM	O	Refer to page 5, 7
16	GND	I	
17	GND	I	
18	GND	I	
19	GND	I	
20	EXT C	-	Connect a 0.1uF capacitor with GND. Refer to next page
21	Vcc	I	Refer to next page
22	GND	I	
23	GND	I	
24	GND	I	
25	GND	I	
26	GND	I	
27	GND	I	
28	Vcc	I	Refer to next page
29	GND	I	
30	Vcc	I	Refer to next page

I: input terminal, O: output terminal

## 6. Recommended peripheral circuit

It is necessary to use the circuit shown below. Please connect decoupling capacitors close to Vcc pins. As data and clock input pins are high impedance, external termination is necessary as close as possible. The type of termination depends on former circuit.

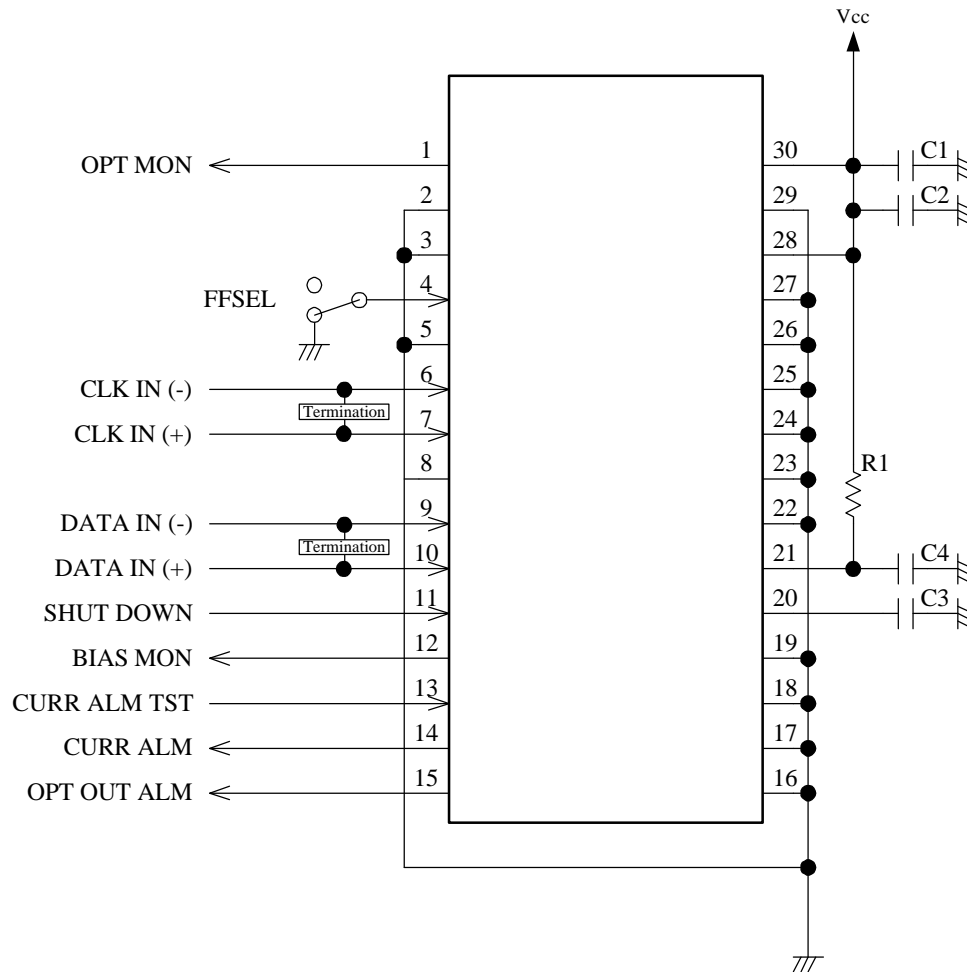
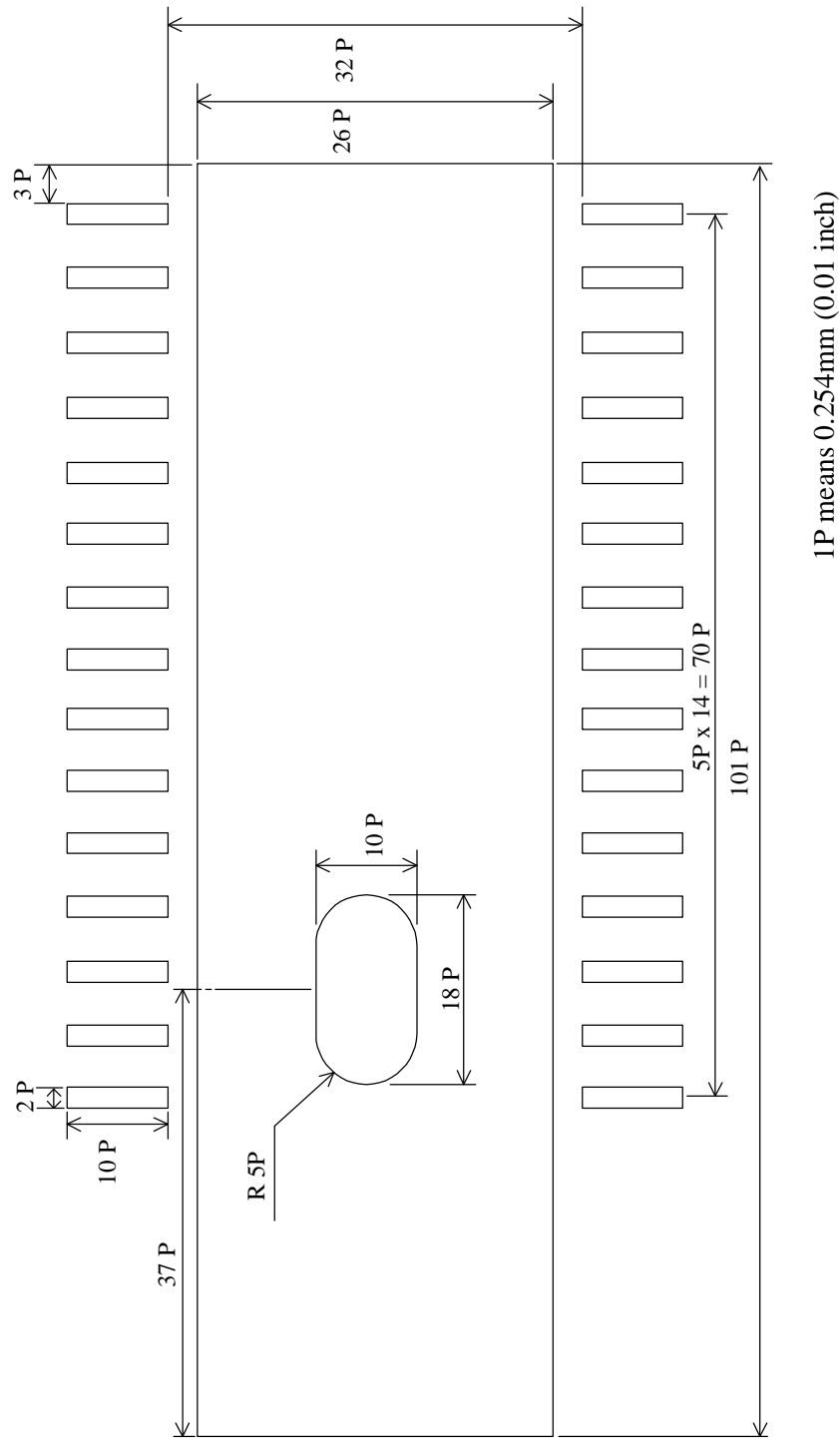

**Fig. 2** Recommended peripheral circuit

### Peripheral circuit part list

Symbol	Description
R1	10 ohm, 1/16W
C1	10 uF +/-20%, 10V
C2	0.1 uF, +20% / -80 %, 10V
C3	0.1 uF, +/-20%, 10V
C4	10 uF +/-20%, 10V

## 7. Pad layout



## 8. Recommended pattern layout

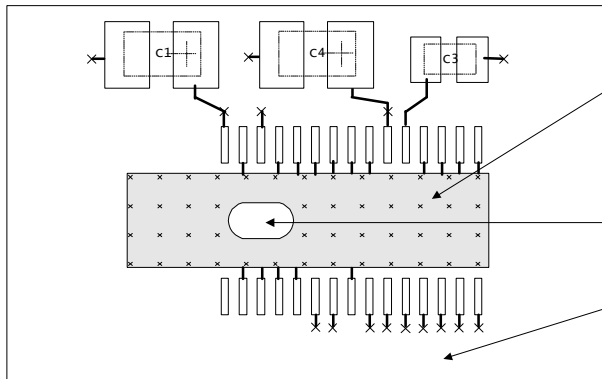

### First Layer (Component side)

a) Please make GND pattern under this device (see Pad Layout on section 7). This GND pattern should be connected to a low impedance GND layer by many through holes.

b) Please don't place any pattern and through holes in this oval area.

c) Please also make GND pattern on a blank area around this device as possible

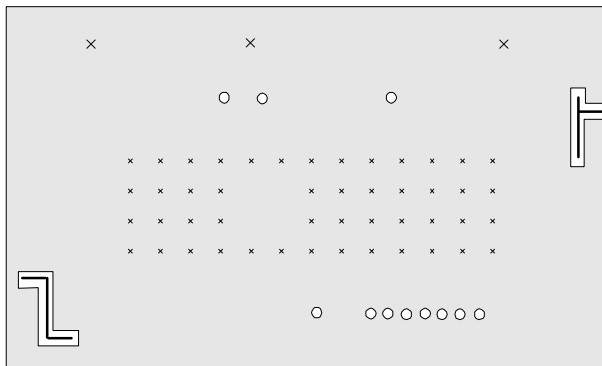

### Second Layer (Ground layer)

x: through holes

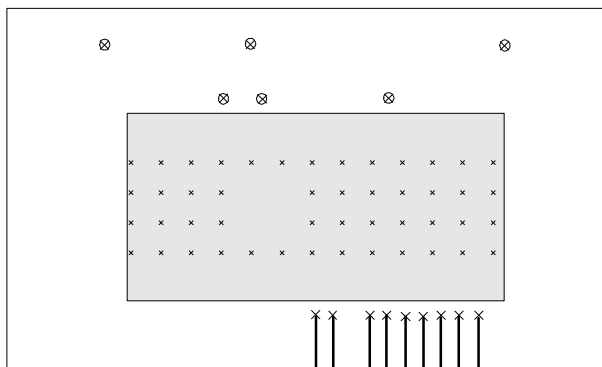

### Third Layer (Signal layer)

Please make GND pattern on a blank area around this device.

x: through holes

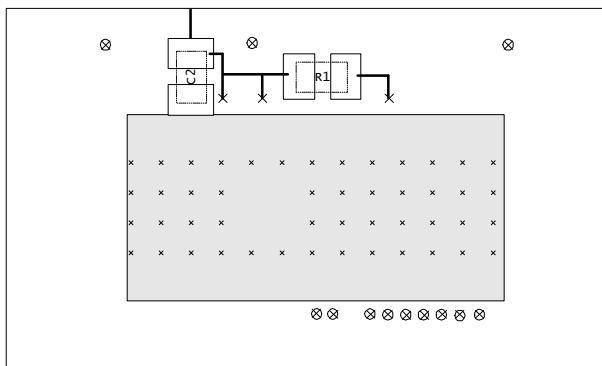

### Fourth Layer (Power supply layer and solderside)

a) Please connect decoupling capacitors close to Vcc pins and GND with low impedance against this device.

b) Please make GND pattern on a blank area around this device as possible.

x: through holes

## 9. Recommended Mounting Conditions

### 9.1 Mount prohibitive area

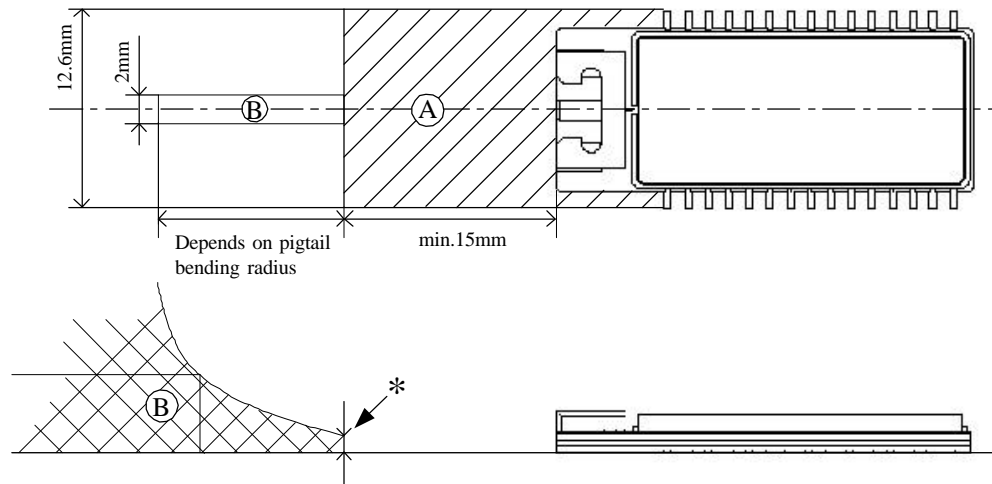

- a) 'A' is necessary space for the pigtail connection tool. Keep this area (12.6mm x 15.0mm) empty.
- b) 'B' is space for pigtail cord. Keep the bending radius of pigtail cord more than 30mm.
- c) Start bending pigtail cord after '\*' point.

### 9.2 Re-flow Soldering Conditions

- a) Soldering temperature: At the temperature more than +200 deg.C, the time should be less than 30 sec., +230 deg.C max.
- b) Pre-heating time: That is not specified particularly (depends on PCB). Typically +150 deg.C, 30 to 60 sec. c)
- Temperature rise and falling time: less than 5 deg.C/ sec.

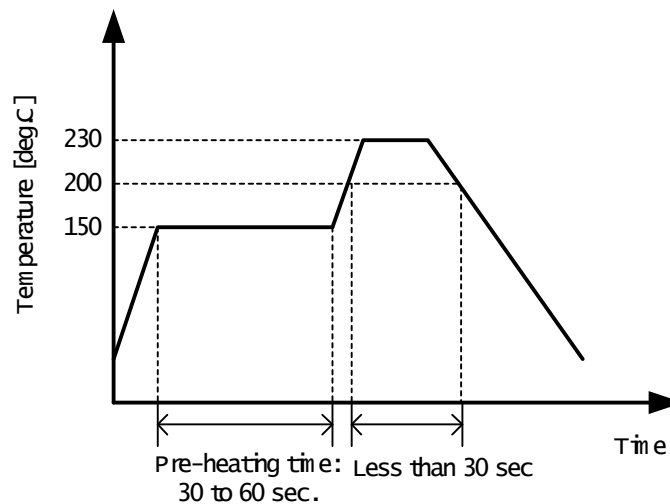

## 9.3 Solvent Cleaning

Solvent cleaning is not recommended.

## 9.4 Mounting Precautions

Do not remove safety cap over the ferrule at the time of re-flow soldering.

Please remove the safety cap after re-flow soldering.

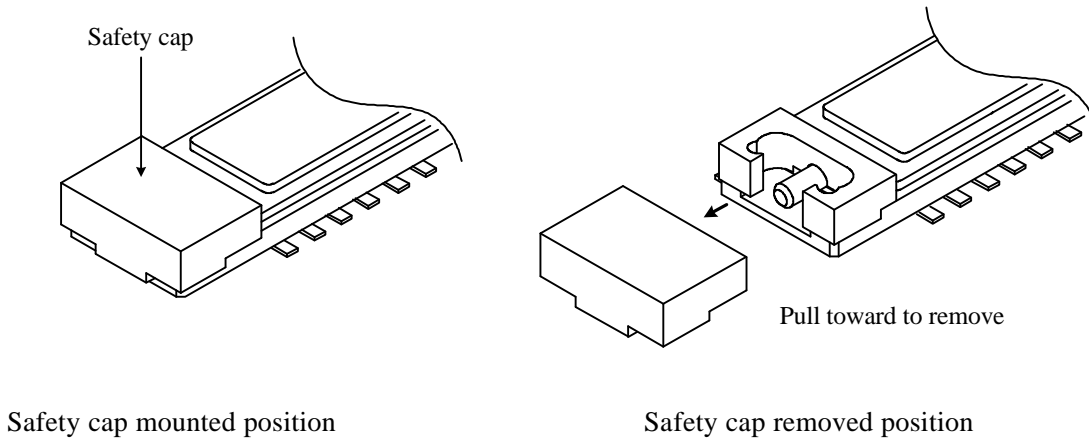

## 9.5 De-soldering from the Printed Board

The product performance is not guaranteed in case of de-soldering from a PCB. If it is necessary to de-solder, Please detach pigtail in advance. Pigtail can be used again.

## 9.6 Pigtail Attachment

Pigtail should be attached after soldering the product on PCB. Please pay attention to following points while attaching a pigtail:

- a) To attach pigtail use pigtail attach / detach tool specially designed for this device.
- b) Please refer to instruction manual of pigtail attach / detach tool for details. (Supplied separately)
- c) Ferrule may be broken upon applying excess strength and its characteristics may be changed.

Don't stretch or bend pigtail cord more than specified values. Recommended value for stretch is less than 200gf and bending radius should be more than 30 mm.

d) Please clean the ferrule surface by a cotton stick before attaching a pigtail.

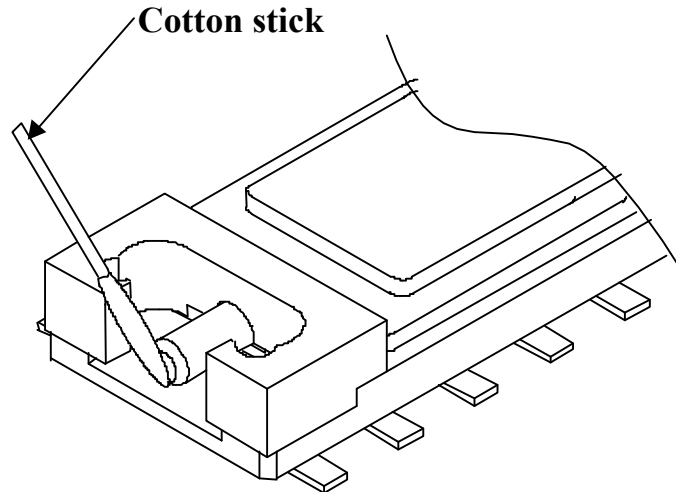

Recommended cotton stick

Maker: NTT-ME

Product name: CLETOP stick type

Product Number: 14100400



## 9.7 Shipment Packing

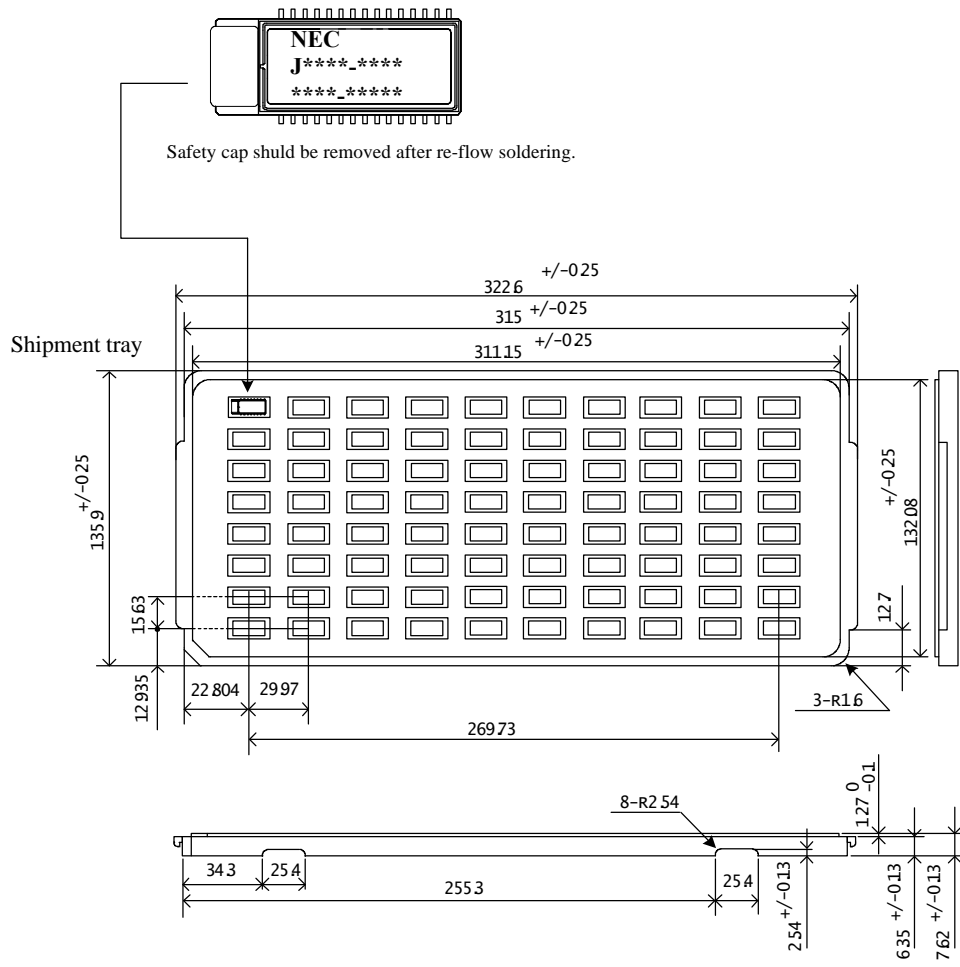

Direction of mounting to the shipment tray

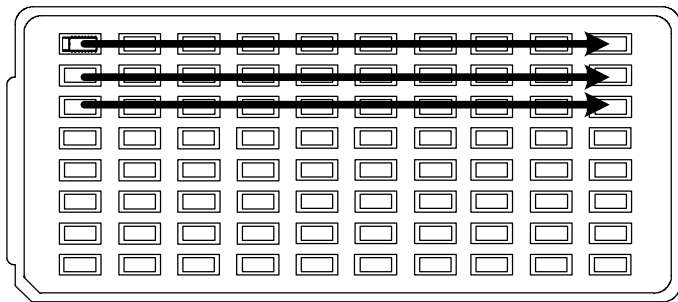

## 10. Application Precautions

- a) To prevent optical connector surface from crack or stain, please put the dust cap while this device is not in use. When the connector surface is stained, please wipe with a kind of lens paper.
- b) The bending radius for pigtail fiber cord should be more than 30mm.
- c) Optical components are mounted inside this device. Please handle with care. Mechanical shock due to falling could lead permanent damage.
- d) The device performance given in this manual is guaranteed for correct applications. Device performances are not guaranteed under incorrect use.
- e) Sudden heating or cooling by dryer or cooling spray could lead permanent damage to the device. The device may not work normally while sudden heating or cooling.
- f) This product should be handled as a CMOS product.