

Temperature Compensated Crystal Oscillators KT14 Series

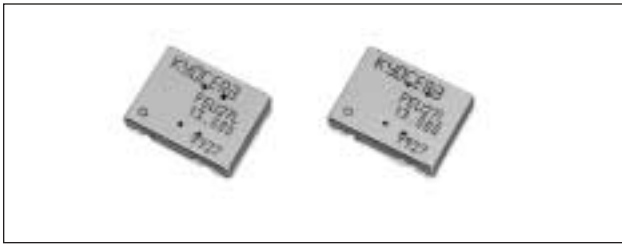

DIMENSIONS

millimeters (inches)

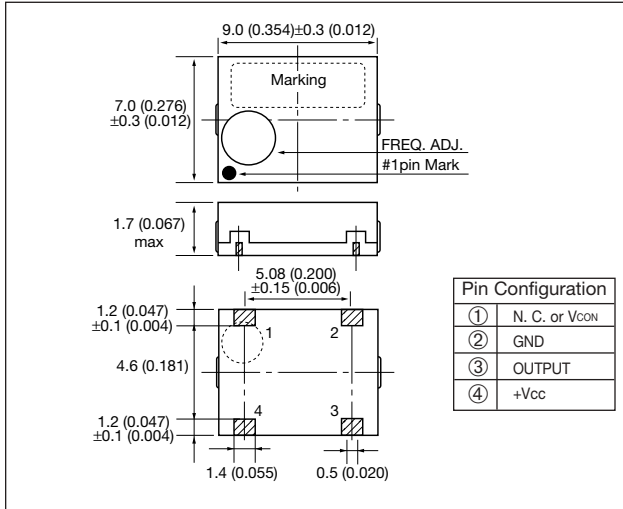

FEATURES

- Low profile SMD type (9.0x7.0x1.7mm)
- AFC function available
- Frequency adjustment free after reflow soldering process
- 2.8, 3.0, 3.3V drive available

APPLICATIONS

- PHS, PDC, GSM, DCS1800, AMPS, CDMA, D-AMPS, PCS1900, etc.

HOW TO ORDER

KT14 - E G R 28 N - 19.200M T

Packaging

T = Tape and reel 2,000 pcs/reel

Frequency (MHz)

12.8000	14.850	19.440
13.000	16.800	19.680
14.400	19.200	19.800

AFC Function

N = No, L = Yes (Trimmerless)

Supply Voltage

28 = 2.8V, 30 = 3.0V

Upper Operating Temp.

V = 80°C, T = 70°C, R = 60°C

Lower Operating Temp.

C = -30°C, G = -10°C, E = -20°C

Frequency Stability

K = ±5ppm, E = ±2.5ppm, D = ±2.0ppm

Series

TEST CIRCUIT

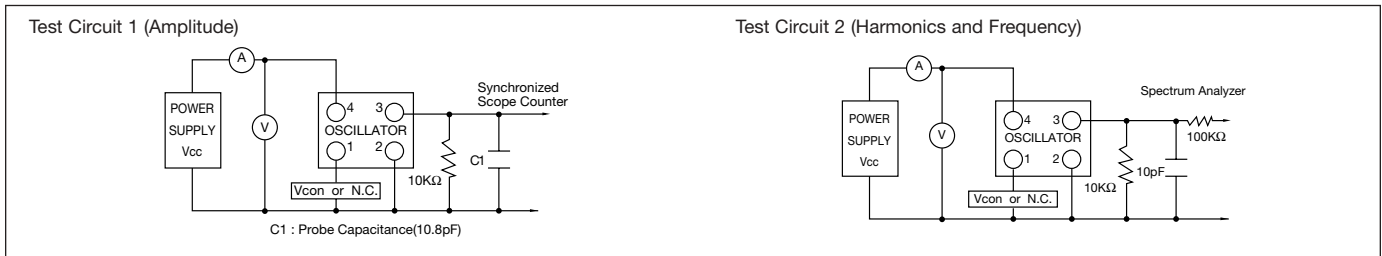

SPECIFICATIONS

Items	Code	Specifications		Unit	Remarks
		PHS	Cellular		
Supply Voltage	Vcc	2.8±5%	2.8±5%	V	—
			3.0±5%		
			3.3±5%		
Output Frequency	fo	19.200	12.800 13.000 14.000	MHz	—
			14.850 16.800		
			19.200 19.440		
			19.680 19.800		
Operating Temperature	Topr	-10 to 60	-30 to +80	°C	—
Storage Temperature	Tstr	-20 to 70	-40 to 85	°C	—
Frequency Stability	Δf/fo	±2.5 max.	±2.0 max.	ppm	vs temperature (after reflow)
			±2.5 max.		
			±0.2 max.		
Aging Rate	Aging	±1.0 max.	±0.3 max.	ppm/year	1 year
			±0.3 max.		
Output Voltage	Vout	0.8 min.	—	Vp-p	load 10kΩ/10pF
Supply Current	Icc	2.0 max.	—	mA	no load
Trimmer Control Range	Δf/C	±3.0 min.	—	ppm	—
Voltage Control Range	Δf/V	—	ex: ±4.0 to ±8.0	ppm	1.5V±1V, 2.5V±1V
Harmonics	—	—	-3.0 max.	dBc	—

Temperature Compensated Crystal Oscillators KT16 Series



FEATURES

- Miniature SMD type (7.0x5.2.0x1.8mm)
- Frequency adjustment free after reflow soldering process
- AFC function available
- 2.7V, 3.0V, 3.3V drive available
- Frequency Stability = ± 2 ppm at 30 to +80°C

APPLICATIONS

- PDC, GSM, CDMA, TDMA

HOW TO ORDER

KT16 - D C V 30 L - 19.680M T

Packaging

T = Tape and reel 4,000 pcs/reel

Frequency (MHz)

12.800	14.850	19.440
13.000	16.800	19.680
14.400	19.200	19.800

AFC Function

V = Yes

Supply Voltage

28 = 2.8V, 30 = 3.0V

Upper Operating Temp.

V = 80°C, T = 70°C, R = 60°C

Lower Operating Temp.

C = -30°C, G = -10°C, E = -20°C

Frequency Stability

K = ± 5 ppm, E = ± 2.5 ppm, D = ± 2.0 ppm

Series

DIMENSIONS

millimeters (inches)

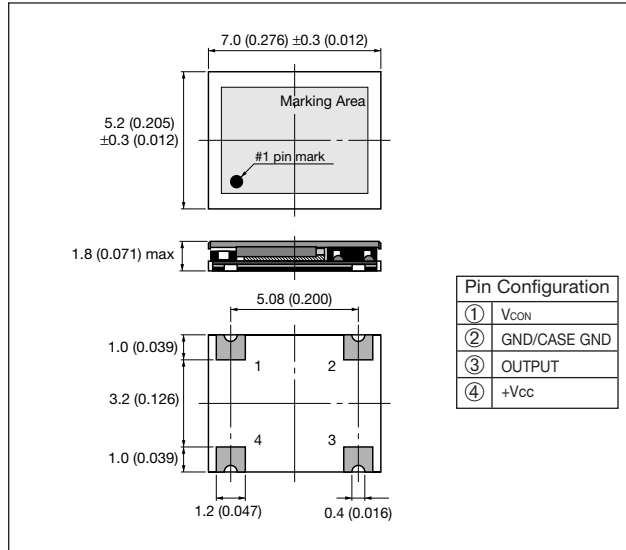

TEST CIRCUIT

Test Circuit 1 (Amplitude)

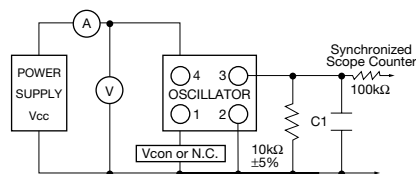

Test Circuit 2 (Harmonics and Frequency)

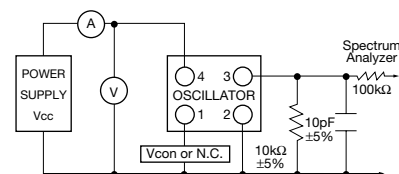

SPECIFICATIONS

Items	Code	Specifications		Unit	Remarks
		Cellular			
Supply Voltage	V _{CC}	2.7		V	—
		3.0			
		3.3			
Output Frequency	f _o	26.000	19.440	MHz	—
		19.680	14.400		
		13.000	12.800		
Operating Temperature	T _{opr}	-30 to +80		°C	—
Storage Temperature	T _{stg}	-40 to +85		°C	—
Frequency Stability	$\Delta f/f_0$	± 2.0 max.		ppm	vs temperature (after reflow)
		± 2.5 max.		ppm	vs load
		± 0.2 max.		ppm	vs voltage
		± 0.3 max.		ppm/year	25°C \pm 2°C
Aging Rate	Aging	± 1.0 max.		ppm/year	—
Output Voltage	V _{out}	0.8 min.		V _{p-p}	load 10k Ω /10pF
Supply Current	I _{CC}	1.5 max.		mA	—
Trimmer Control Range	$\Delta f/C$	—		ppm	—
Voltage Control Range	$\Delta f/V$	± 8.0 to ± 15		ppm	—
Harmonics	—	-3.0 max.		dBc	—

Temperature Compensated Crystal Oscillators KT18 Series



FEATURES

- Miniature SMD type (5.0x3.2x1.5mm)
- Frequency adjustment free after reflow soldering process
- AFC function available
- 2.6 to 5.5V drive available
- Frequency Stability = ± 2 ppm at 30 to +80°C

APPLICATIONS

- PDC, GSM, CDMA, TDMA

HOW TO ORDER

KT18 - D C V 30 A - 19.680M T

Packaging

T = Tape and reel 4,000 pcs/reel

Frequency (MHz)

12.800	16.800	19.680
13.000	19.200	19.800
14.400	19.440	26.000

AFC Function

A = Yes

Supply Voltage

28 = 2.8V, 30 = 3.0V

Upper Operating Temp.

V = 80°C, T = 70°C, R = 60°C

Lower Operating Temp.

C = -30°C, G = -10°C, E = -20°C

Frequency Stability

K = ± 5 ppm, E = ± 2.5 ppm,

D = ± 2.0 ppm

Series

DIMENSIONS

millimeters (inches)

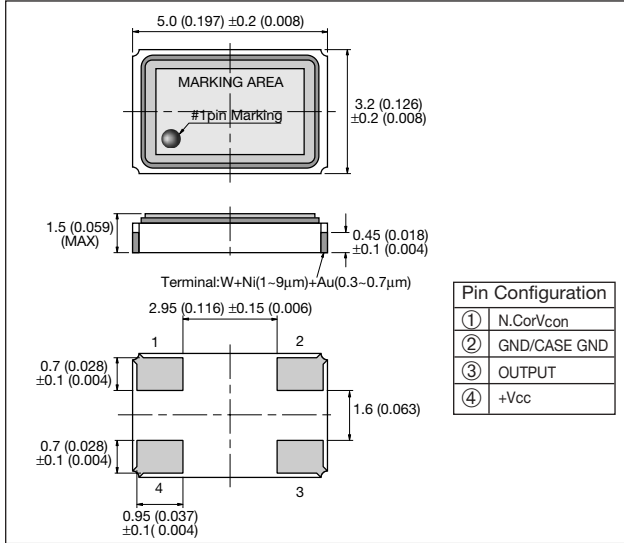

TEST CIRCUIT

Test Circuit 1 (Amplitude)

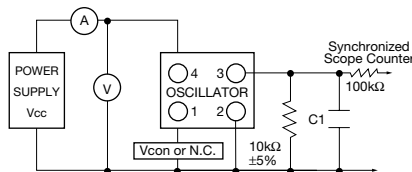

Test Circuit 2 (Harmonics and Frequency)

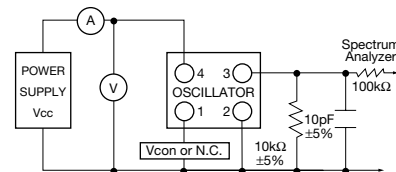

SPECIFICATIONS

Items	Code	Specifications			Unit	Remarks
		Cellular				
Supply Voltage	Vcc	2.6 to 5.5			V	—
Output Frequency	fo	26.000	19.440	19.200	MHz	—
		19.680	14.400	19.800		
		13.000	12.800	16.800		
Operating Temperature	Topr	-30 to +80			°C	—
Storage Temperature	Tstg	-40 to +85			°C	—
Frequency Stability	$\Delta f/f_0$	± 1.5 max.			ppm	vs temperature (after reflow)
		± 2.0 max.			ppm	vs load
		± 0.2 max.			ppm	vs voltage
		± 0.3 max.			ppm	—
Aging Rate	Aging	± 1.0 max.			ppm/year	25°C ± 2 °C
Output Voltage	Vout	0.8 min.			Vp-p	load 10k Ω /10pF
Supply Current	Icc	2.0 max.			mA	—
Trimmer Control Range	$\Delta f/C$	—			ppm	—
Voltage Control Range	$\Delta f/V$	± 8.0 to ± 15			ppm	—
Harmonics	—	-3.0 max.			dBc	—

Temperature Compensated Crystal Oscillators



RECOMMENDED LAND PATTERN

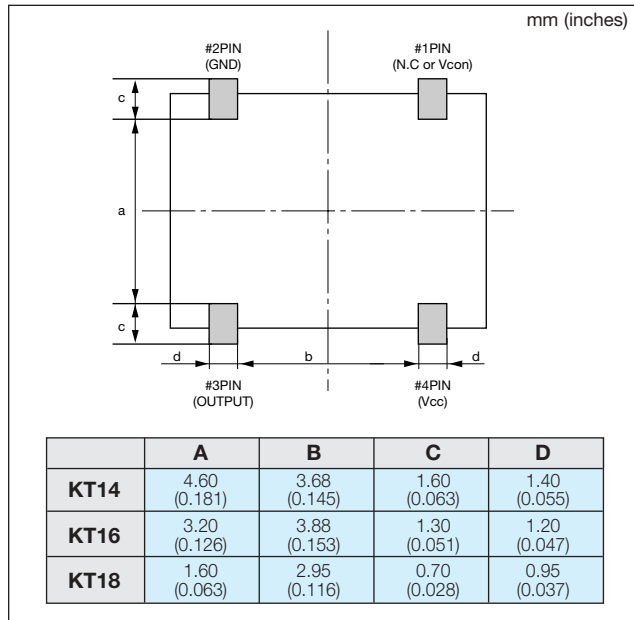

REEL DIMENSIONS

millimeters (inches)

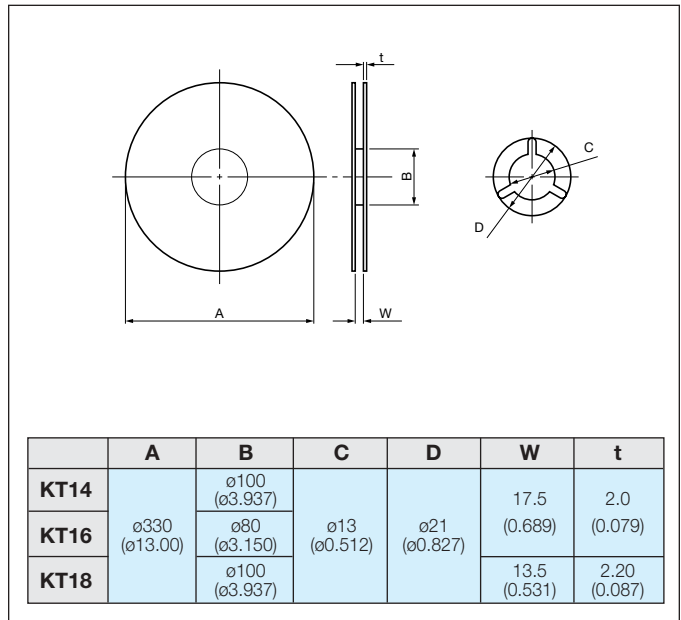

PACKAGING

millimeters (inches)

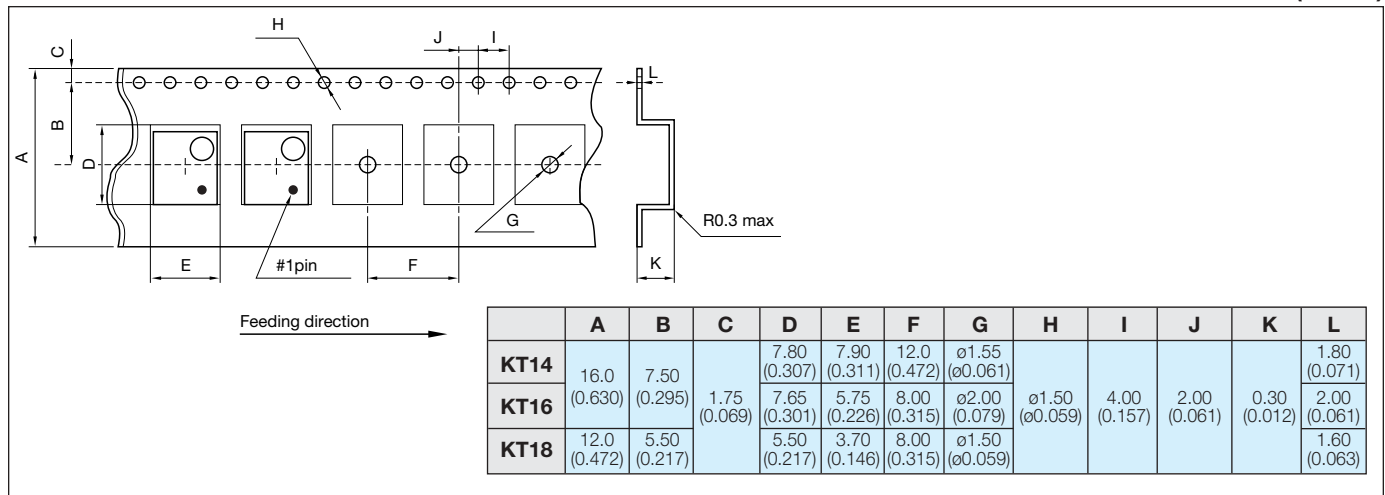

RECOMMENDED REFLOW PROFILE

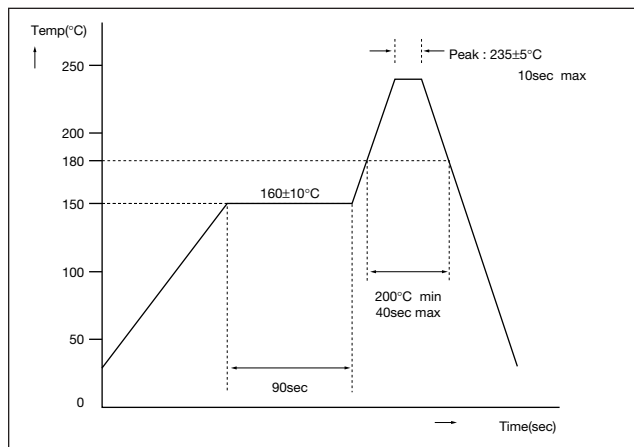

PACKAGING

KT14: 2,000 pcs/reel
 KT16/KT18: 4,000 pcs/reel