

The information disclosed herein was originated by and is the property of Densitron International. Densitron International reserves all patent, proprietary, design, use, sales, manufacturing and reproduction rights thereto

REVISIONS

REV.	DESCRIPTION	DATE	APPROVED
01	PRE-RELEASE	3/19/99	M.A.

1. **Specification subject to change without notice.**
2. **All dimensions and specifications apply to standard modules. This information may vary for modules with optional features.**
3. **All dimensions are in millimeters.**
4. **Precautions: These precautions apply equally to modules from all makers, not just Densitron. Violation of these guidelines may void the warranty and can cause problems ranging from erratic operation to catastrophic display failure.**

Handling precautions:

- ◆ This device is susceptible to Electro-Static Discharge (ESD) damage. Observe Anti-Static precautions.

Power supply precautions:

- ◆ Identify and, at all times, observe absolute maximum ratings for both logic and LC drivers. Note that there is some variance between models.
- ◆ Prevent the application of reverse polarity to V_{DD} and V_{SS}, however briefly.
- ◆ Use a clean power source free from transients. Power up conditions are occasionally "jolting" and may exceed the maximum ratings of the module.
- ◆ The +5V power of the module should also supply the power to all devices which may access the display. Don't allow the data bus to be driven when the logic supply to the module is turned off.
- ◆ DO NOT install a capacitor between the V_O (contrast) pin and ground. V_{DD} must, at all times, exceed the V_O voltage level. The capacitor combines with the contrast potentiometer to form an R-C network which "holds-up" V_O, at power-down, possibly damaging the module.

Operating precautions:

- ◆ DO NOT plug or unplug the module when the system is powered up.
- ◆ Minimize the cable length between the module and host MPU. (Recommended max. length 30 cm).
- ◆ For models with EL backlights, do not disable the backlight by interrupting the HV line. Unloaded inverters produce voltage extremes which may arc within a cable or at the display.
- ◆ Operate the module within the limits of the modules temperature specifications.

Mechanical / Environmental precautions:

- ◆ Improper soldering is the major cause of module difficulty. Use of flux cleaner is not recommended as they may seep under the elastomeric connection and cause display failure. Densitron recommends the use of Kester "245" no-clean solder.
- ◆ Mount the module so that it is free from torque and mechanical stress.
- ◆ Surface of LCD panel should not be touched or scratched. The display front surface is an easily scratched, plastic polarizer. Avoid contact and clean only when necessary with soft, absorbent cotton dampened with petroleum benzene.
- ◆ ALWAYS employ anti-static procedure while handling the module.
- ◆ Prevent moisture build-up upon the module and observe the environmental constraints for storage temperature and humidity.
- ◆ DO NOT store in direct sunlight.
- ◆ If leakage of the liquid crystal material should occur, avoid contact with this material, particularly ingestion. If the body or clothing becomes contaminated by the liquid crystal material, wash thoroughly with water and soap.

Notes: (unless otherwise specified)

Unless otherwise specified: Dimensions are mm Tolerances are: X = ± 3 .X = ± 0.5 .XX = ± 0.05 FSCM NO. 62483	APPROVALS	DATE	DENSITRON INTERNATIONAL PLC. TITLE 128 X 240 PIXEL INDUSTRIAL TOUCH MONITOR	
	DRAWN			
	CHECKED		DWG. NO.	TS4229

1.0 DESCRIPTION

Industrial Touch Input Monitor consisting of a Liquid Crystal Display, analog resistive touch panel, CMOS driver and controller LSI, printed circuit board, metal support frame and array type Light Emitting Diode (LED) backlight.

Available LC fluids types are: NTN (supertwisted nematic), NTN-H (extended temperature range NTN).

Options include on-board negative voltage generation and temperature compensation.

2.0 MECHANICAL CHARACTERISTICS

Item	Specifications	Unit
Package Dimensions	144.0 x 104.0 x 17.4	mm
Display format	240 x 128	-
Driving method	1/128	duty
Dot size	0.4 x 0.4	mm
Dot pitch	0.45 x 0.45	mm
Active display area	107.95 x 57.55	mm
Viewing area	114.0 x 64.0	mm
Weight		g
Surface hardness	>2H	H
Reflex Time	<30	mS
Touch Durability	1,000,000	Operations

Notes:W-Width;H-Height;D-Depth.

3.0 ABSOLUTE MAXIMUM RATINGS

V_{SS}=0V;T_a=25°C

Item	Symbol	TN, NTN		TN-H, NTN-H		Unit
		Min.	Max.	Min.	Max.	
Logic supply voltage	V _{DD} -V _{SS}	0	7	0	7	V
LC driver supply voltage	V _{DD} -V _O	0	6	0	-25	V
Operating temperature	TOP	0	+50	-20	+70 (Note 3)	°C
Storage temperature (Note 1)	TST	-20	+70	-30	+80	
Humidity: Operating (@40°C)	-	-	85%	-	85%	RH (Note 2)
Non-operating (@40°C)	-	-	95%	-	95%	RH (Note 2)

Notes: 1: Tested to 100 hrs.
2: Refers to non-condensing conditions.
3: With backlight off.

4.0 ELECTRICAL CHARACTERISTICS

V_{DD}=5±0.25V;T_a=25°C

Item	Symbol	Test Condition	Min.	Typ.	Max.	Unit
Input "High" voltage	V _{IH}	-	2.2	-	V _{DD}	V
Input "Low" voltage	V _{IL}	-	-	-	0.6	V
Output "High" voltage	V _{OH}	I _{OH} =0.205mA	2.4	-	-	V
Output "Low" voltage	V _{OL}	I _{OL} =1.2mA	-	-	0.4	V
Power supply current	I _{ee}	V _{ee} =-20V	-	7.0	-	mA
Power supply current	I _{dd}	V _{dd} =5.0 V	-	30.0	-	

4.1 TOUCH INPUT CHARACTERISTICS

ITO coating resistance	X axis 300-600 ohms Y axis 300-600 ohms
Action resistance	<3k ohms (when pressed with a rubber head at 100g force)
Power consumption	<1mA

5.0 RECOMMENDED LC DRIVE VOLTAGE ($V_{DD}-V_O$)

$V_{DD}=5.0\pm 0.25V$

Temperature	NTN	NTN-H
Ta= -20°C		24.3
Ta= 0°C	21.0	21.0
Ta= 25°C	18.5	18.5
Ta= 50°C	16.8	16.8
Ta=70°C		15.7

6.0 BACKLIGHT SPECIFICATIONS:

Ta=20°C,60%RH,Darkroom.

Item	Symbol	Typ.	Max.	Unit
LED input voltage	VLED	5.0	6.0	V
LED input current	ILED	660	825	mA
Built-in current limiting resistor	R1	-	-	Ohms, W
External current limiting resistor (recommended)	R2	1 Ohm, 1W	-	Ohms, W
Number of nodes	N	110	-	-

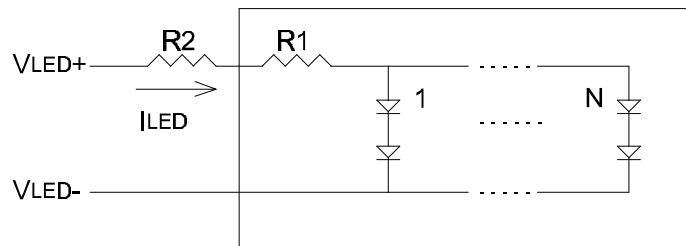

7.0 POWER SUPPLY

• NTN, NTN-H

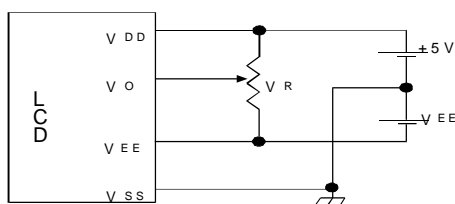

• NTN, NTN-H with on-board negative voltage generator

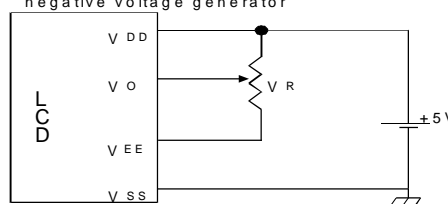

$V_R = 10K - 20K \text{ ohm}$

• NTN, NTN-H with temperature compensation



• NTN, NTN-H with on-board negative voltage generator and temperature compensation

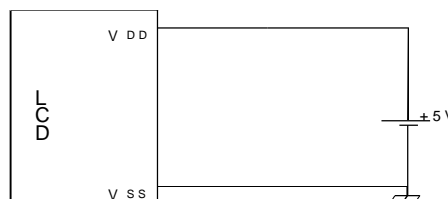

DWG. NO.

TS4229

SHEET 3 OF 13

REV. 01

8.0 INTERFACE DESCRIPTION

Pin No.	Symbol	I/O	Function
1	VSS	-	Ground (0V)
2	VDD	-	Logic Supply Voltage (+5V)
3	Vo	-	LC Drive voltage for contrast adjustment
4	C/D	I	WR='L'...C/D='H': command write C/D='L': Data write RD='L'... C/D='H' :status read C/D='L': Data read
5	RD	I	Data read Active Low
6	RW	I	Data write active low
7	DB0	I/O	Bi-directional data bus line 0
8	DB1	I/O	Bi-directional data bus line 1
9	DB2	I/O	Bi-directional data bus line 2
10	DB3	I/O	Bi-directional data bus line 3
11	DB4	I/O	Bi-directional data bus line 4
12	DB5	I/O	Bi-directional data bus line 5
13	DB6	I/O	Bi-directional data bus line 6
14	DB7	I/O	Bi-directional data bus line 7
15	CE	I	Chip enable active low
16	Reset	I	Chip reset active low
17	Vee	I(O)	negative voltage input for LC drive (negative voltage output for models with on-board negative voltage generator)
18	MD2	I	Mode selection (see below)
19	FS1	I	Terminal for font size selection
20	HALT	-	H=normal, L= stop oscillator
BL1	VLED+	-	LED anode
BL2	VLED-	-	LED cathode
TS1	X1	I/O	analogue touch screen top bus bar
TS2	X2	I/O	analogue touch screen bottom bus bar
TS3	Y1	I/O	analogue touch screen left bus bar
TS4	Y2	I/O	analogue touch screen right bus bar

Font Selection

Font Select	MD2	FS1
6x8	L	H
8x8	H	L

10.0 DTSC01 CONTROLLER CIRCUIT (OPTIONAL)

The DTSC01 has been designed to allow the user simple TTL or RS232 serial interfacing to any 4,5 or 8 wire analogue resistive touch system, for example the Densitron range of industrial touch monitors.

Description

Once power is applied to the DTSC01, data is made available on the output of the PCB at connector J3 and J4.

This data appears in a constant stream containing the following:

- 10 bits of X position data
- 10 bits of Y position data
- 1 bit touch actuation control

This data is sent in 3 packets of 8 bits.

In addition to the data output the DTSC01 will respond to a number of specific setup commands to tune the response of the touch panel to the application in which it is used. This consists of:

- ◆ Baud Rate
- ◆ Touch Mode
- ◆ Averaging
- ◆ Speed
- ◆ Noise rejection

POWER

DTSC01 is a low power device. It requires 5V $\pm 20\%$ @20mA on J2 connector.

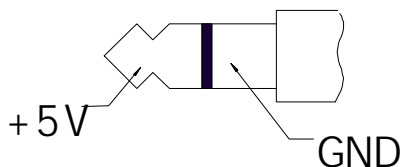

SERIAL CONNECTOR

The interface with the PC is through a standard D-type connector.

D-type connector J3		
Pin No.	Symbol	Function
1	N/C	Not Connected
2	TxD	Transmit Data
3	RxD	Receive Data
4	N/C	Not Connected
5	GND	Ground
6	N/C	Not Connected
7	N/C	Not Connected
8	N/C	Not Connected
9	N/C	Not Connected

TTL level signals are output through optional pin header J4. It is useful for connecting to a microprocessor directly.

TTL level connector J4		
Pin No.	Symbol	Function
1	RxD TTL	Receive Data (TTL level)
2	TxD TTL	Transmit Data (TTL level)
3	TxD	Transmit Data
4	RxD	Receive Data
5	GND	Ground

TOUCH OVERLAY CONNECTOR

Touch overlay connector J1		
Pin No.	Symbol	Function
1	SY-	Y-sense
2	Y-	Y-drive
3	SY+	Y+sense
4	Y+	Y+drive
5	SX-	X-sense
6	X-	X-drive
7	SX+	X+sense
8	X+	X+drive
9	S4	Not used
10	5W	5 TH wire sense
11	S3	Not used
12	GND	Ground
13	S2	Not used
14	Vcc	3.3V power
15	S1	Not used
16	+5V	5V±20% power supply

General Operation

After power has been applied to the circuit, data will be streamed from J4 & J3. This will appear as follows:

Bit	7	6	5	4	3	2	1	0
Data	1	T	X9	X8	X7	Y9	Y8	Y7
Data	0	X6	X5	X7	X3	X2	X1	X0
Data	0	Y6	Y5	Y4	Y3	Y2	Y1	Y0

T = 0 for release data touch mode

T = 1 for press data touch mode

Example

With the device in continuous touch mode the reading looks like:

```
11 x9x8x7y9y8y7
0x6x5x4x3x2x1x0
0y6y5y4y3y2y1y0
```

In press only touch mode and release only touch mode:

```
11 x9x8x7y9y8y7
0x6x5x4x3x2x1x0
0y7y5y4y3y2y1y0
10 x9x8x7y9y8y7
```

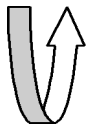

loops round

stop

for touch and release points respectively.

Set up commands

As standard the device is shipped pre-configured as follows:-

BAUD RATE – 2400 baud, no parity, 8 data bits, 1 stop bit
 TOUCH MODE – Continuous data stream
 AVERAGING – 32 samples per reading
 SPEED – Auto switching off
 NOISE REJECT - High noise rejection

Command	D7 -----D0	Hex	
BAUD RATE	0 1 0 0 0 1 0 0	44	2400 baud rate
	0 1 0 0 1 1 0 0	4B	9600 baud rate
	0 0 0 0 0 0 0 0	00	4 samples per reading
	0 0 0 0 0 0 0 1	01	8 " " "
FILTERING	0 0 0 0 0 0 1 0	02	16 " " "
	0 0 0 0 0 0 1 1	03	32 " " "
	0 1 0 0 0 0 0 1	41	Data sent on release
TOUCH MODE	0 1 0 0 0 0 1 0	42	Data sent on press
	0 1 0 0 0 0 1 1	43	Data sent continuously
	0 0 0 0 0 5 0 0	04	Enable auto speed switch
AUTO SPEED SENSE	0 0 0 0 0 5 0 0	04	Enable auto speed switch
NOISE REJECTION	0 0 N 0 0 0 0 0	20	High noise rejection

Example Programming

To modify any of the parameters in the setup the DTSC01 will respond to the following header code (01H). This will hold the controller in a command receive mode for approximately 100mS. If no further data is received within this period then the device will touch out and return to normal operation.

All commands must be terminated with ODH, after which the device will return to normal operation.

EG: To change the DTSC01 baud rate to 9600 (from factory set 2400) 01 4B OD

Note: To help with timing data write information, the DTSC01 will echo all information back to the host.

11.0 LCD Instruction Set

Commands	D7	D6	D5	D4	D3	D2	D1	D0	Description	Execute Time
Pointer Set	0	0	1	0	0	N2	N1	N0		Status
						0	0	1	Cursor Pointer Set	Check
						0	1	0	Offset Register Set	
						1	0	0	Address Pointer Set	
Control Word	0	1	0	0	0	0	N1	N0		32 X /fosc
Set commands							0	0	Text Home Address Set	
							0	1	Text Area Set	
							1	0	Graphic Home Address Set	
							1	1	Graphic Area Set	
Mode Set	1	0	0	0	C0	N2	N1	N0		32 x 1/fosc
					0				CG ROM Mode	
					1				CG RAM Mode	
						0	0	0	OR Mode	
						0	0	1	EXOR Mode	
						0	1	1	AND Mode	
						1	0	0	Text only (attribute capability)	
Display Modes	1	0	0	1	N3	N2	N1	N0		32 x 1/fosc
					0				Graphics Off	
					1				Graphics On	
						0			Text Off	
						1			Text On	
							0		Cursor Off	
							1		Cursor On	
								0	Cursor blink Off	
								1	Cursor blink On	
Cursor Pattern	1	0	1	0	0	N2	N1	N0	N2~N0: No. of lines for cursor+1	32 x 1/fosc
Select							0	0	0	Bottom Line cursor
							0	0	1	2 line cursor
							1	1	1	8 line cursor (block cursor)
Data Auto	1	1	0	0	0	0	N1	N0		32 x 1/fosc
Read/Write							0	0	Data Auto Write Set	
							0	1	Data Auto Read Set	
							1	0	Auto reset (Address pointer auto-incremented) for continuous rd/wr	
Data Read/Write	1	1	0	0	0	N2	N1	N0		
						0			Address Pointer up/down	
						1			Address Pointer unchanged	
							1		Address Pointer down	
								0	Data Write	
								1	Data Read	

Screen Peeking	1	1	1	0	0	0	0	0	0	Read Displayed Data	Status
Screen Copy (Note 3)	1	1	1	0	1	0	0	0	0	Copies 1 line of displayed data whose address is indicated by the Address Pointer to Graphic RAM area	Status check
Bit Set/Reset	1	1	1	1	N	N	N	N	N	N2~N0 indicates the bit in the pointed address	Status check
					0					Bit Reset	
					1					Bit Set	
						0	0	0		Bit 0 (LSB)	
						0	0	1		Bit 1	
						1	1	1			
						1	1	1		Bit 7 (MSB)	

Note:

1. *= DON'T CARE
2. Read the status of the STA0 and STA1 Flags before each new command or data byte is sent to the T6963C. If these two flags are set (i.e.=1) then the T6963C is not busy processing the previous instruction and it is safe to write a new command or data byte to the T6963C. If a new instruction is sent to the T6963C while these two flags are not set (i.e.=0), then that command shall be ignored by the T6963C.
3. In the case of a dual screen LCD the screen copy command should not be used.

Note: full programming data on the T6963 controller is available at www.denstron.com

12.0 OPTICAL CHARACTERISTICS

Item	Symbol	Test Condition	Min.	Typ.	Max.	Unit
Contrast ratio TN, TN-H	K	$\varnothing=20^\circ \theta=0^\circ$	3	-	-	-
Contrast ratio NTN	K	$\varnothing=20^\circ \theta=0^\circ$	4	-	-	-
Contrast ratio NTN-H	K	$\varnothing=20^\circ \theta=0^\circ$	5	-	-	-
Viewing angle TN, TN-H	$\varnothing 2-\varnothing 1$ θ	$\theta=0^\circ K \geq 1.4$ $\varnothing=20^\circ K=1.4$	20 ± 30	-	-	Deg. Deg.
Viewing angle NTN	$\varnothing 2-\varnothing 1$ θ	$\theta=0^\circ K \geq 1.4$ $\varnothing=20^\circ K=1.4$	40 ± 30	-	-	Deg. Deg.
Viewing angle NTN-H	$\varnothing 2-\varnothing 1$ θ	$\theta=0^\circ K \geq 1.4$ $\varnothing=20^\circ K=1.4$	40 ± 40	-	-	Deg. Deg.
Response time Rise	t_r	$\varnothing=20^\circ \theta=0^\circ$	-	150	250	mS
Fall	t_f	$\varnothing=20^\circ \theta=0^\circ$	-	150	250	mS

DEFINITION OF CONTRAST RATIO (K)

$$K = \frac{\text{Brightness of non-selected dots}}{\text{Brightness of selected dots}}$$

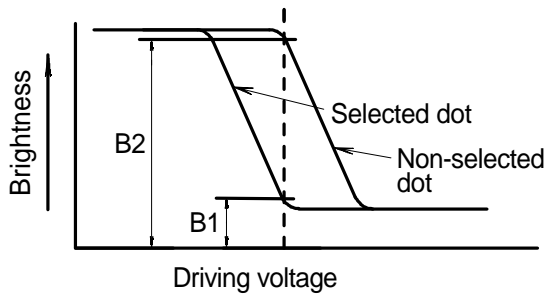

CONTRAST VERSUS VIEWING ANGLE

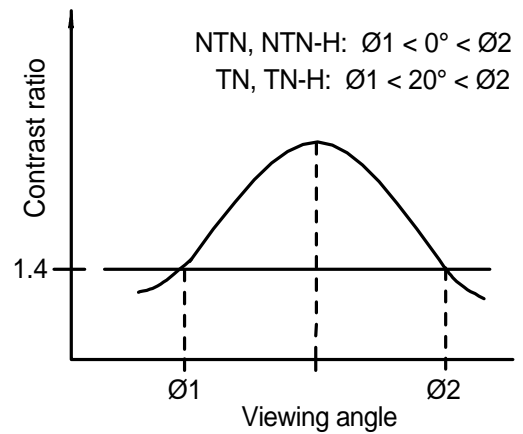

DEFINITION OF ANGLES \varnothing AND θ

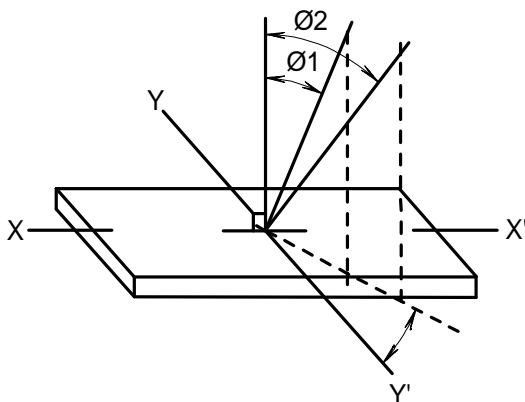

DEFINITION OF OPTICAL RESPONSE

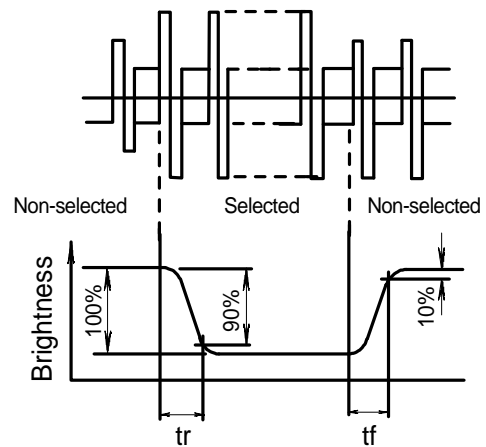

14.0 PART NUMBER DESCRIPTION FOR AVAILABLE OPTIONS

TS4229①②128G240③④⑤

①

POLARIZER TYPE

B = Transflective: light background with LED backlight
E = Transmissive: dark background with LED backlight

②

BACKLIGHT COLOR

G = Yellow-Green (Standard)

③

FLUID TYPE AND POWER SUPPLY

D = NTN with +5VDC and external negative voltage operation
S = NTN with +5VDC operation (on-board negative voltage generation)
H = NTN-H with +5VDC and external negative voltage operation
W = Wide temperture range: on-board negative voltage generator

④

FLUID TYPE

N = NTN, NTN-H

⑤

COLOR FOR NTN FLUID

B = Blue background (available for E polarizer type only)
G = Gray background (available for B polarizers types only)
Y = Yellow background (available for B polarizers types only)

13.0 MODULE DIMENSIONS

