

The information disclosed herein was originated by and is the property of Densitron International. Densitron International reserves all patent, proprietary, design, use, sales, manufacturing and reproduction rights thereto.

REVISIONS			
REV.	DESCRIPTION	DATE	APPROVED
A	RELEASED ON ECN #E0218	7/28/95	MA

1. **Specification subject to change without notice.**
2. **All dimensions and specifications apply to standard modules. This information may vary for modules with optional features.**
3. **All dimensions are in millimeters.**
4. **Precautions: These precautions apply equally to modules from all makers, not just Densitron. Violation of these guidelines may void the warranty and can cause problems ranging from erratic operation to catastrophic display failure.**

Handling precautions:

- ◆ This device is susceptible to Electro-Static Discharge (ESD) damage. Observe Anti-Static precautions.

Power supply precautions:

- ◆ Identify and, at all times, observe absolute maximum ratings for both logic and LC drivers. Note that there is some variance between models.
- ◆ Prevent the application of reverse polarity to VDD and Vss, however briefly.
- ◆ Use a clean power source free from transients. Power up conditions are occasionally "jolting" and may exceed the maximum ratings of the module.
- ◆ The +5V power of the module should also supply the power to all devices which may access the display. Don't allow the data bus to be driven when the logic supply to the module is turned off.
- ◆ DO NOT install a capacitor between the Vo (contrast) pin and ground. VDD must, at all times, exceed the Vo voltage level. The capacitor combines with the contrast potentiometer to form an R-C network which "holds-up" Vo, at power-down, possibly damaging the module.

Operating precautions:

- ◆ DO NOT plug or unplug the module when the system is powered up.
- ◆ Minimize the cable length between the module and host MPU. (Recommended max. length 30 cm).
- ◆ For models with EL or CCFL backlights, do not disable the backlight by interrupting the HV line. Unloaded inverters produce voltage extremes which may arc within a cable or at the display.
- ◆ Operate the module within the limits of the modules temperature specifications.

Mechanical / Environmental precautions:

- ◆ Improper soldering is the major cause of module difficulty. Use of flux cleaner is not recommended as they may seep under the elastomeric connection and cause display failure. Densitron recommends the use of Kester "245" no-clean solder.
- ◆ Mount the module so that it is free from torque and mechanical stress.
- ◆ Surface of LCD panel should not be touched or scratched. The display front surface is an easily scratched, plastic polarizer. Avoid contact and clean only when necessary with soft, absorbent cotton dampened with petroleum benzene.
- ◆ ALWAYS employ anti-static procedure while handling the module.
- ◆ Prevent moisture build-up upon the module and observe the environmental constraints for storage temperature and humidity.
- ◆ DO NOT store in direct sunlight.
- ◆ If leakage of the liquid crystal material should occur, avoid contact with this material, particularly ingestion. If the body or clothing becomes contaminated by the liquid crystal material, wash thoroughly with water and soap.

Notes: (unless otherwise specified)

Unless otherwise specified: Dimensions are mm Tolerances are: X = ± 3 .X = ± 0.5 .XX = ± 0.05 FSCM NO. 62483	APPROVALS	DATE	DENSITRON INTERNATIONAL PLC.	
	DRAWN MAA			
	CHECKED JLH		TITLE 240 X 128 GRAPHICS LCD MODULE	
	ISSUED MAA		DWG. NO. LM3129	SHEET 1 OF 8

1.0 DESCRIPTION

Dot matrix display module consisting of liquid Crystal Display, CMOS driver and Hitachi HD61830B, printed circuit board, metal support frame.

Available LC fluid types are: NTN (supertwisted nematic) and NTN-H (extended temperature range NTN).

Other options include electroluminescent (EL) backlighting, on-board negative voltage generation circuitry and on-board temperature compensation circuitry.

2.0 MECHANICAL CHARACTERISTICS

Item	Specifications	Unit
Package Dimensions	144.0 (W) x 104.0 (H) x 17.8 max (D)	mm
Display format	240 dots (W) x 128 dots (H)	-
Driving method	1/128	duty
Dot size	0.40 (W) x 0.40 (H)	mm
Dot pitch	0.45 (W) x 0.45(H)	mm
Active display area	107.95 (W) x 57.55 (H)	mm
Viewing area	114.0 (W) x 64.0 (H)	mm
Weight		g

Notes: W-Width; H-Height; D-Depth.

3.0 ABSOLUTE MAXIMUM RATINGS

V_{SS}=0V; T_a=25°C

Item	Symbol	NTN		NTN-H		Unit
		Min.	Max.	Min.	Max.	
Logic supply voltage	V _{DD} -V _{SS}	0	7	0	7	V
LC driver supply voltage	V _{DD} -V _{EE}	0	-25	0	-25	V
Operating temperature	T _{OP}	0	+50	-20	+70 (Note 3)	°C
Storage temperature (Note 1)	T _{ST}	-20	+70	-30	+80	
Humidity: Operating (@40°C)	-	-	85%	-	85%	RH (Note 2)
Non-operating (@40°C)	-	-	95%	-	95%	RH (Note 2)

Notes: 1: Tested to 100 hrs.
 2: Refers to non-condensing conditions.
 3. It is not recommended to operate EL lamp above +50°C.

4.0 ELECTRICAL CHARACTERISTICS

V_{DD}=5±0.25V; T_a=25°C

Item	Symbol	Test Condition	Min.	Typ.	Max.	Unit
Input "High" voltage	V _{IH}	-	0.8	-	V _{DD}	V
Input "Low" voltage	V _{IL}	-	V _{SS}	-	0.2V _{DD}	V
Output "High" voltage	V _{OH}	I _{OH} =0.205mA	2.2	-	-	V
Output "Low" voltage	V _{OL}	I _{OL} =1.2mA	-	-	0.8	V
Power supply current	I _{EE}	V _{EE} =-20V	-	7	-	mA
Power supply current	I _{DD}	V _{DD} =5.0V	-	30.0	-	mA

5.0 RECOMMENDED LC DRIVE VOLTAGE (V_{DD}-V_O)

V_{DD}=5.0±0.25V

Temperature	NTN	NTN-H
T _a = -20°C	-	24.3
T _a = 0°C	21.0	21.0
T _a = 25°C	18.5	18.5
T _a = 50°C	16.8	16.8
T _a =70°C	-	15.7

6.0 BACKLIGHT SPECIFICATIONS:

T_a=20°C,60%RH,Darkroom.

Item	Symbol	Typ.	Max.	Unit
EL lamp input voltage	VEL	100	150	V _{rms}
EL lamp input current	IEL	21.0	25.0	mA
Life to half initial brightness	-	2500	3000	Hours
EL lamp input frequency	FEL	400	800	KHz
Recommended backlight inverter	-	DAS5V14	-	-

7.0 POWER SUPPLY

- NTN, NTN-H

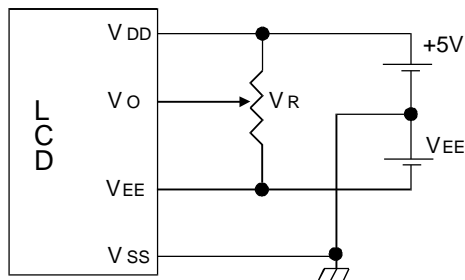

- NTN, NTN-H with on-board negative voltage generator

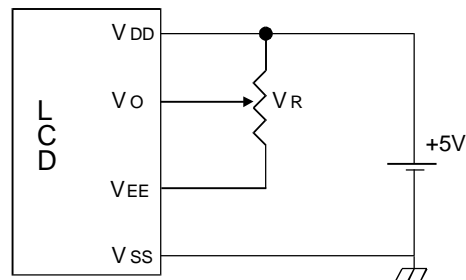

V_R = 10K - 20K ohm

- NTN, NTN-H with temperature compensation

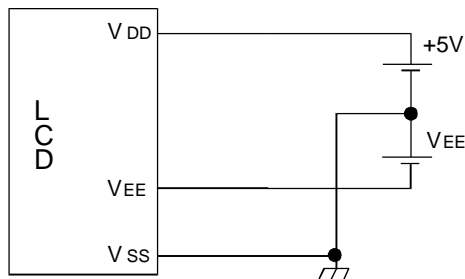

- NTN, NTN-H with on-board negative voltage generator and temperature compensation

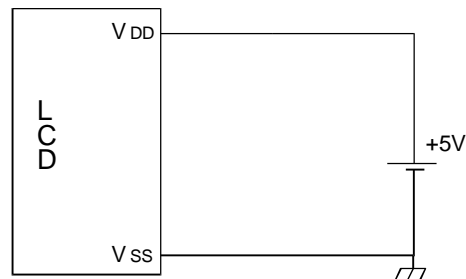

8.0 INTERFACE DESCRIPTION

Pin No.	Symbol	I/O	Function
1	Vss	-	Ground (0V)
2	VDD	-	Logic Supply Voltage (+5V)
3	Vo	-	LC drive voltage for contrast adjustment.
4	RS	I	Register Select 0: Instruction Register 1: Data Register
5	R/W	I	Read / Write 0: Data Write (Module ← MPU) 1: Data Read (Module → MPU)
6	E	I	Enable Signal
7	DB0	I/O	Bi-directional data bus line 0
8	DB1	I/O	Bi-directional data bus line 1
9	DB2	I/O	Bi-directional data bus line 2
10	DB3	I/O	Bi-directional data bus line 3
11	DB4	I/O	Bi-directional data bus line 4
12	DB5	I/O	Bi-directional data bus line 5
13	DB6	I/O	Bi-directional data bus line 6
14	DB7	I/O	Bi-directional data bus line 7
15	CS	I	Chip Select (Active Low)
16	RST	I	Reset (Active Low)
17	VEE	I(O)	Negative voltage input for LC drive (Negative voltage output for models with on-board negative voltage generator)
18	N/C	-	No connection
19	N/C	-	No connection
20	N/C	-	No connection
BL1	VEL	-	EL backlight input voltage (from output of DC-AC inverter)
BL2	VEL	-	EL backlight input voltage (from output of DC-AC inverter)

9.0 BLOCK DIAGRAM

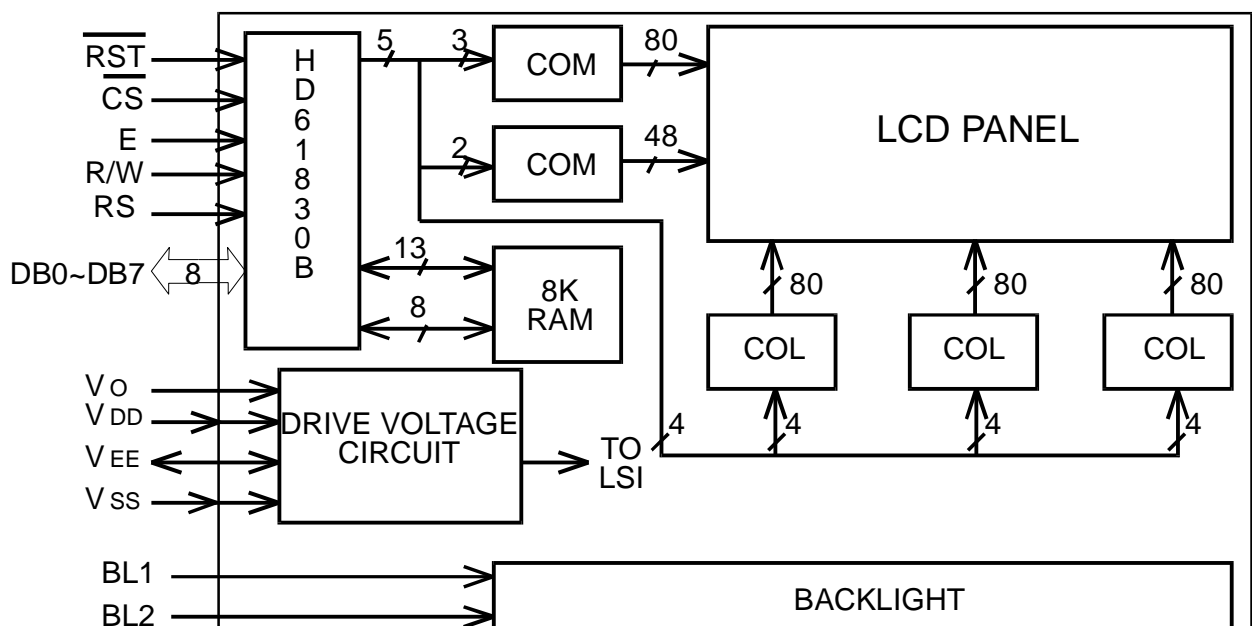

10.0 TIMING CHARACTERISTICS

Item	Symbol	Min.	Typ.	Max.	Unit
Enable cycle time	t_{cyc}	1.0	-	-	μS
Enable pulse width	t_{WEH}, t_{WEL}	450	-	-	nS
Enable rise /fall time	t_{Er}, t_{Ef}	-	-	25	nS
Address set-up time	t_{AS}	140	-	-	nS
Address hold time	t_{AH}	10	-	-	nS
Data delay time	t_{DDR}	-	-	225	nS
Data hold time	T_{DHW}	10	-	-	nS
Data set-up time	t_{DSW}	225	-	-	nS

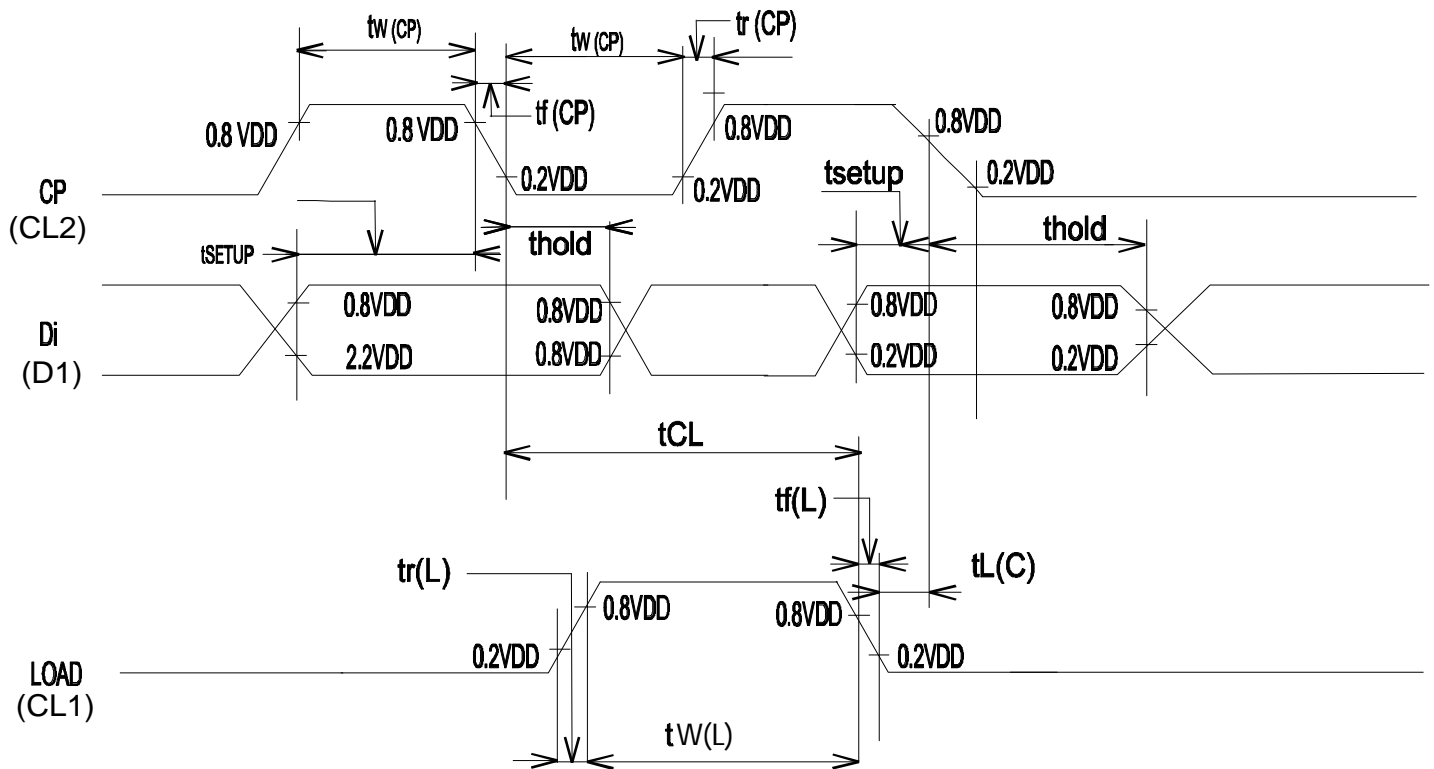

11.0 VOLTAGE SEQUENCING

To prevent applying a DC voltage to the LC panel and inducing an electro-chemical effect, please observe the following power supply ON/OFF sequence to prevent DC driving of LC panel or latching-up of CMOS LSI circuits:

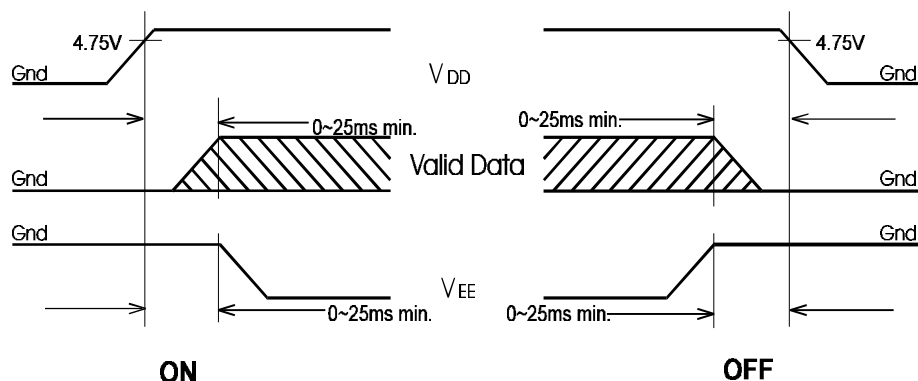

12.0 OPTICAL CHARACTERISTICS

Item	Symbol	Test Condition	Min.	Typ.	Max.	Unit
Contrast ratio	K	$\theta=20^\circ \theta=0^\circ$	4	-	-	-
Viewing angle	$\theta 2-\theta 1$	$\theta=0^\circ K>1.4$	40	-	-	Deg.
	θ	$\theta=20^\circ K=1.4$	± 30	-	-	Deg.
Response time	Rise	$\theta=20^\circ \theta=0^\circ$	-	150	250	mS
	Fall	$\theta=20^\circ \theta=0^\circ$	-	150	250	mS

DEFINITION OF CONTRAST RATIO (K)

$$K = \frac{\text{Brightness of non-selected dots}}{\text{Brightness of selected dots}}$$

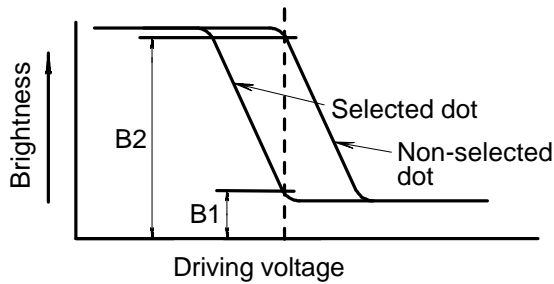

θ

DEFINITION OF ANGLES θ AND

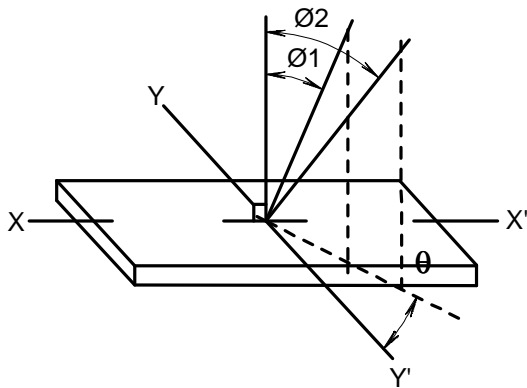

CONTRAST VERSUS VIEWING ANGLE

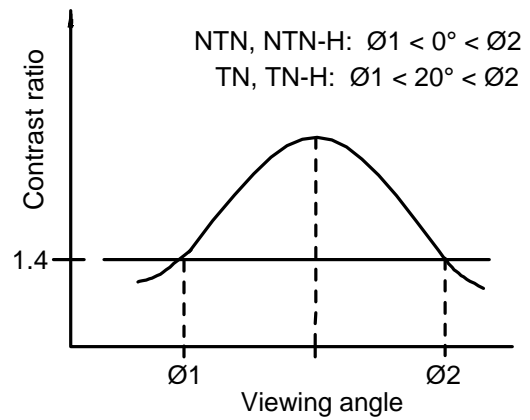

DEFINITION OF OPTICAL RESPONSE

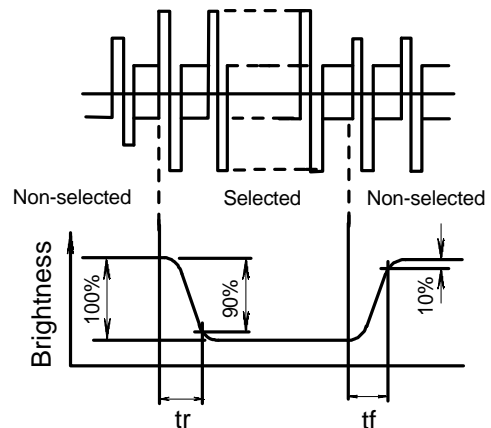

13.0 MODULE DIMENSIONS

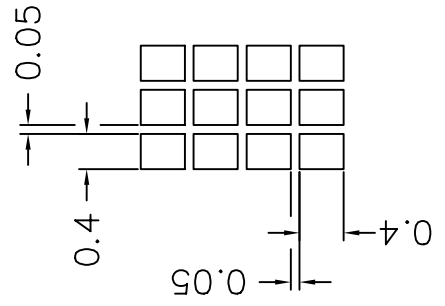
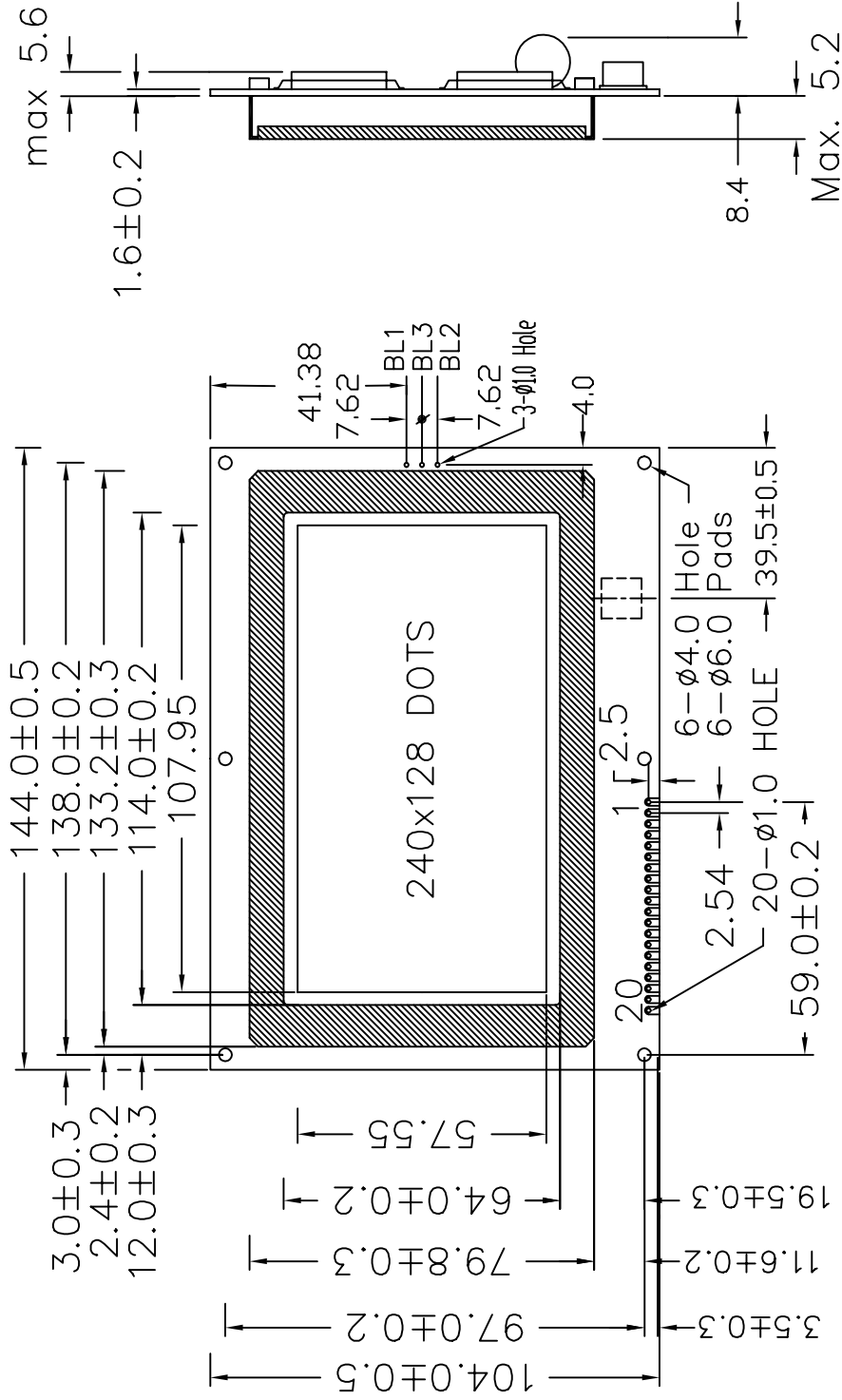

14.0 PART NUMBER DESCRIPTION FOR AVAILABLE OPTIONS

LM3129①②128G240③④⑤

①

POLARIZER TYPE

A = Reflective: light background, no backlight

B = Transflective: light background with white EL backlight

②

NOT APPLICABLE - LEAVE BLANK

③

FLUID TYPE AND POWER SUPPLY

D = NTN with +5VDC and external negative voltage operation

S = NTN with +5VDC operation (on-board negative voltage generation)

H = NTN-H with +5VDC and external negative voltage operation

W = NTN-H with +5VDC operation (on-board negative voltage generation)

④

FLUID TYPE AND TEMPERATURE COMPENSATION CIRCUIT

C = NTN, NTN-H with on-board temperature compensation circuitry

N = NTN, NTN-H

⑤

COLOR FOR NTN FLUID

G = Gray background

Y = Yellow background