



Features

- ☑ Designed for ATM/SONET/SDH OC-1 to OC-12 (52 Mb/s, 156 Mb/s & 622 Mb/s), FDDI, Fibre Channel (266 & 531 Mb/s)
- ☑ Long Reach 1310 nm & 1550 nm as well as Intermediate Reach
- ☑ Eye Safe (Class I Laser Safety)
- ☑ - 40°C to +85°C Operating Temperature
- ☑ Multi-sourced 1x9 package style
- ☑ Duplex SC or ST or FC connector
- ☑ Single +5 V supply & PECL interface
- ☑ Conductive Plastic or Metal packages
- ☑ Wave Solder Process Compatible

Description

The DTR-xxx-SM fiber optic transceivers offer a simple, convenient way to interface PCBs to single mode fiber optic cables. Many performance versions are available which are fully compliant with SONET/SDH standards from OC-1 to OC-12 for both Long Reach (1310 nm & 1550 nm) and Intermediate Reach as well as FDDI and Fibre Channel specifications. All modules satisfy Class I Laser Safety requirements in accordance with the US FDA/CDRH and international IEC-825 standards.

The transmit and receive functions are contained in a single one-row, 9-pin (1x9) package with a Duplex SC or ST or FC connector interface. The transmitter incorporates a highly reliable 1300 nm or 1550 nm InGaAsP Laser and a driver

circuit which converts Pseudo Emitter Coupled Logic (PECL) data to light. The receiver incorporates an efficient InGaAs/InP PIN photodiode converting the light signal into an electrical current which is amplified and regenerated into PECL-compatible data. The transimpedance amplifier IC has internal AGC for wide dynamic range. A Signal Detect status output flag is also provided.

The transceiver operates from a single +5V power supply over an operating temperature range of 0°C to +70°C ("Blank" option) or - 40°C to +85°C ("A" option). The transceiver package is made of either *conductive* plastic (Duplex-SC version) with blue color or metal (FC and ST version) for excellent EMI shielding.

Absolute Maximum Ratings

Parameter	Symbol	Minimum	Maximum	Units
Storage Temperature	T_{st}	- 40	+ 85	°C
Operating Temperature	T_{op}	"A" option	+ 85	°C
		"blank" option	0	
Supply Voltage	V_{cc}	- 0.5	+ 6.0	V
Input Voltage	V_{in}	- 0.5	V_{cc}	V
Output Current	I_o	-	50	mA
Lead Soldering Temperature & Time	-	-	260°C, 10 sec	

OC-1 Single Mode Transceiver: DTR-052-SM

Transmitter Performance Characteristics (over Operating Case Temperature, $V_{CC} = 4.75$ to $5.25V$)

Parameter		Symbol	Minimum	Typical	Maximum	Units
Data Rate		B	5	52	100	Mb/s
Optical Output Power ¹	L0	P_o	- 5.0	- 3.0	0	dBm
	L1		- 8.0	- 5.0	- 2.0	
	L2		- 12.0	- 8.0	- 5.0	
	L3		- 15.0	- 11.0	- 8.0	
Center Wavelength		λ_c	1261	1310	1360	nm
Spectral Width (RMS)		$\Delta\lambda_{RMS}$	-	-	4.0	nm
Extinction Ratio		P_{hi}/P_{lo}	10	-	-	dB
Optical Rise and Fall Time (10% to 90%)		t_r, t_f	-	2.0	4.0	ns
Optical Output Eye		compliant with Bellcore TR-NWT-000253				
¹ Measured average power coupled into single mode fiber. The minimum power specified is at Beginning-of-Life (BOL).						

Receiver Performance Characteristics (over Operating Case Temperature, $V_{CC} = 4.75$ to $5.25V$)

Parameter		Symbol	Minimum	Typical	Maximum	Units
Data Rate		B	5	52	100	Mb/s
Receiver Sensitivity (10^{-10} BER) ¹		P_{min}	- 38.0	- 40.0	-	dBm
Maximum Input Optical Power (10^{-10} BER) ¹		P_{max}	- 7.0	0	-	dBm
Signal Detect Thresholds	Increasing Light Input	P_{sd+}	-	-	- 38.0	dBm
	Decreasing Light Input	P_{sd-}	- 50.0	-	-	
Signal Detect Hysteresis ²			1.5	-	-	dB
Signal Detect Timing Delay	Increasing Light Input	t_{sd+}	-	-	100	μs
	Decreasing Light Input	t_{sd-}	-	-	350	
Wavelength of Operation		λ	1100	-	1600	nm
¹ Specified in Average Optical Input Power and measured at 52 Mb/s and 1300 nm wavelength with $2^{23}-1$ PRBS.						
² At $T_a = 25^\circ C$. The minimum hysteresis over Operating Temperature & Supply Voltage is 1.0 dB.						

Ordering Information

DTR - 052 - SM - XX -T- Ln

Receptacle

Blank: SC Receptacle
 ST : ST Receptacle
 FC : FC Receptacle

Temperature Range

Blank: $0^\circ C$ to $+70^\circ C$
 A : $-40^\circ C$ to $+85^\circ C$

Light Output Option

L0: - 3 dBm (typ.)
 L1: - 5 dBm (typ.)
 L2: - 8 dBm (typ.)
 L3: - 11 dBm (typ.)

FDDI Single Mode Transceiver: DTR-125-SM

Transmitter Performance Characteristics (over Operating Ambient Temperature, $V_{CC} = 4.75$ to $5.25V$)

Parameter		Symbol	Minimum	Typical	Maximum	Units
Data Rate		B	5	125	266	Mb/s
Optical Output Power ¹	L- II	P_o	- 4.0	- 3.0	0	dBm
	L- I		- 19.0	-	- 14.0	
Center Wavelength	L- II	λ_c	1290	-	1330	nm
	L- I		1270	-	1340	
Spectral Width (RMS)		$\Delta\lambda_{RMS}$	-	-	5.0	nm
Extinction Ratio		P_{hi}/P_{lo}	10	-	-	dB
Optical Rise and Fall Time (10% to 90%)		t_r, t_f	-	1.0	2.0	ns
Random Jitter (peak-to-peak)		RJ	-	-	0.76	ns
Duty Cycle Distortion (peak-to-peak)		DCD	-	-	1.0	ns
Data Dependent Jitter (peak-to-peak)		DDJ	-	-	0.6	ns

¹ Measured average power coupled into single mode fiber. The minimum power specified is at Beginning-of-Life (BOL).

Receiver Performance Characteristics (over Operating Ambient Temperature, $V_{CC} = 4.75$ to $5.25V$)

Parameter		Symbol	Minimum	Typical	Maximum	Units
Data Rate		B	5	125	266	Mb/s
Minimum Input Optical Power ¹	L- II	P_{min}	- 37.0	- 38.0	-	dBm
	L- I		- 32.5	- 35.0	-	
Maximum Input Optical Power ¹		P_{max}	- 14.0	- 12.0	-	dBm
Signal Detect Thresholds	Increasing Light Input	L- II	-	-	- 37.0	dBm
		L- I	-	-	- 32.5	
	Decreasing Light Input	L- II	- 51.0	-	-	dBm
		L- I	- 45.0	-	-	
Signal Detect Hysteresis			1.5	-	-	dB
Signal Detect Timing Delay	Increasing Light Input	t_{sd+}	-	-	100	μs
	Decreasing Light Input	t_{sd-}	-	-	350	
Wavelength of Operation		λ	1100	-	1600	nm

¹ Specified in Average Optical Input Power and measured per FDDI Single mode PMD document.

Operating Temperature Range for DTR-125-SM

Parameter		Symbol	Minimum	Typical	Maximum	Units
Operating Temperature	L- II	T_{op}	+ 10	-	+ 50	°C
	L- I		0	-	+ 60	

Ordering Information

DTR - 125 - SM - XX - L - N

Receptacle

Blank: SC Receptacle

ST : ST Receptacle

FC : FC Receptacle

Category

II or I

NOTES

- The DTR-125-SM-xx-L-II is fully compliant with the FDDI Single mode PMD standard for Category II.
- The DTR-125-SM-xx-L-I is fully compliant with the FDDI Single mode PMD standard for Category I.

OC-3/STM-1 Single Mode Transceiver: DTR-156-SM

Transmitter Performance Characteristics (over Operating Case Temperature, $V_{CC} = 4.75$ to $5.25V$)

Parameter		Symbol	Minimum	Typical	Maximum	Units
Data Rate		B	50	156	300	Mb/s
Average Optical Output Power (coupled into single mode fiber), 50% duty cycle	L0	P_o	- 5.0	- 3.0	0	dBm
	L1		- 8.0	- 5.0	- 2.0	
	L2		- 12.0	- 8.0	- 5.0	
	L3		- 15.0	- 11.0	- 8.0	
Extinction Ratio		P_{hi} / P_{lo}	10	-	-	dB
Center Wavelength	IR (Intermediate Reach)	λ_c	1261	1310	1360	nm
	LR1 (Long Reach 1310 nm)		1280	1310	1335	
	LR2 (Long Reach 1550 nm)		1480	1550	1580	
Spectral Width (RMS)	LR1 (0°C to 70°C) & IR	$\Delta\lambda_{RMS}$	-	-	4	nm
Spectral Width (-20 dB)	LR1 (-40°C to 85°C) & LR2	$\Delta\lambda_{20}$	-	-	1	
Side Mode Suppression Ratio	LR1 (-40°C to 85°C) & LR2	$SMSR$	30	-	-	dB
Optical Rise and Fall Time (10% to 90%)		t_r, t_f	-	1	2	ns
Optical Output Eye	compliant with Bellcore TR-NWT-000253 and ITU-T Recommendation G.957					

Receiver Performance Characteristics (over Operating Case Temperature, $V_{CC} = 4.75$ to $5.25V$)

Parameter		Symbol	Minimum	Typical	Maximum	Units
Data Rate		B	50	156	266	Mb/s
Receiver Sensitivity (10^{-10} BER) ¹	IR	P_{min}	- 31.0	- 34.0	-	dBm
	"Blank" or LR1 or LR2		- 34.0	- 37.0	-	
Maximum Input Optical Power (10^{-10} BER) ¹		P_{max}	- 7.0	0	-	dBm
Signal Detect Thresholds	Increasing Light Input	IR	-	-	- 31.0	dBm
			"Blank" or LR1 or LR2	-	-	
	Decreasing Light Input		P_{sd-}	- 45.0	-	
Signal Detect Hysteresis		-	1.0	-	-	dB
Signal Detect Timing Delay	Increasing Light Input	t_{sd+}	-	-	100	μs
	Decreasing Light Input	t_{sd-}	-	-	100	
Wavelength of Operation		λ	1100	-	1600	nm

¹ Specified in Average Optical Input Power and measured at 1300 nm wavelength (1550 nm for LR2 option) with 2^{23} -1 PRBS. The Receiver Sensitivity is specified at 156 Mb/s with a minimum eye opening of 1.3 ns.

Ordering Information

DTR - 156 - SM - XX - T - Ln - DR

<p>Receptacle</p> <p>Blank: SC Receptacle ST : ST Receptacle FC : FC Receptacle</p>	<p>Temperature Range</p> <p>Blank: 0°C to +70°C A : - 40°C to +85°C</p>	<p>Light Output Option</p> <p>L0: - 3 dBm (typ.) L1: - 5 dBm (typ.) L2: - 8 dBm (typ.) L3: - 11 dBm (typ.)</p>	<p>Distance Option</p> <p><i>specifies the range for Center Wavelength & Spectral Width to be compliant with SONET/SDH standard</i></p> <p>Blank: Receiver has Long Reach sensitivity IR : Intermediate Reach / S-1.1 LR1 : Long Reach 1310 nm / L-1.1 LR2 : Long Reach 1550 nm / L-1.2</p>
--	--	---	--

NOTES

1. For full compliance with OC-3/STM-1 Intermediate Reach / S-1.1 standard, the DTR-156-SM-xx-T-L3-IR modules are recommended.
2. The DTR-156-SM-xx-A-L3 & DTR-156-SM-xx-L3 modules can also be used for OC-3/STM-1 Intermediate Reach / S-1.1 standard. They offer better sensitivity (their receiver sensitivity performance satisfies the Long Reach sensitivity requirement).
3. For full compliance with OC-3/STM-1 Long Reach 1310 nm / L-1.1 standard, the DTR-156-SM-xx-T-L0-LR1 modules are recommended. The DTR-156-SM-xx-A-L0-LR1 uses a DFB laser to satisfy the - 40°C to +85°C requirement for Center Wavelength.
4. For full compliance with OC-3/STM-1 Long Reach 1550 nm / L-1.2 standard, the DTR-156-SM-xx-T-L0-LR2 are recommended. Both modules use DFB lasers. However, the DTR-156-SM-xx-A-L0-LR2 is specified only over - 25°C to +70°C.
5. The LR1 (-40°C to +85°C) & LR2 options are available only with DFB lasers and L0 optical output power level.

266 Mb/s Fibre Channel Single Mode Transceiver: DTR-266-SM

Transmitter Performance Characteristics (over Operating Case Temperature, $V_{CC} = 4.75$ to $5.25V$)

Parameter		Symbol	Minimum	Typical	Maximum	Units
Data Rate		B	5	266	320	Mb/s
Optical Output Power ¹	L0	P_o	- 5.0	- 3.0	0	dBm
	L1		- 8.0	- 5.0	- 2.0	
	L2		- 12.0	- 8.0	- 5.0	
	L3		- 15.0	- 11.0	- 8.0	
Center Wavelength		λ_c	1261	1310	1360	nm
Spectral Width (RMS)		$\Delta\lambda_{RMS}$	-	-	4.0	nm
Extinction Ratio		P_{hi}/P_{lo}	10	-	-	dB
Optical Rise and Fall Time (10% to 90%)		t_r, t_f	-	1.0	2.0	ns
Duty Cycle Distortion (peak-to-peak)		DCD	-	-	0.6	ns

¹ Measured average power coupled into single mode fiber. The minimum power specified is at Beginning-of-Life (BOL).

Receiver Performance Characteristics (over Operating Case Temperature, $V_{CC} = 4.75$ to $5.25V$)

Parameter		Symbol	Minimum	Typical	Maximum	Units
Data Rate		B	5	266	320	Mb/s
Receiver Sensitivity (10^{-10} BER) ¹		P_{min}	- 30.0	- 32.0	-	dBm
Maximum Input Optical Power (10^{-10} BER) ¹		P_{max}	- 7.0	0	-	dBm
Signal Detect Thresholds	Increasing Light Input	P_{sd+}	-	-	- 30.0	dBm
	Decreasing Light Input	P_{sd-}	- 45.0	-	-	
Signal Detect Hysteresis ²			1.5	-	-	dB
Signal Detect Timing Delay	Increasing Light Input	t_{sd+}	-	-	100	μs
	Decreasing Light Input	t_{sd-}	-	-	350	
Wavelength of Operation		λ	1100	-	1600	nm

¹ Specified in Average Optical Input Power and measured at 266 Mb/s and 1300 nm wavelength with $2^{23}-1$ PRBS.
² At $T_a = 25^\circ C$. The minimum hysteresis over Operating Temperature & Supply Voltage is 1.0 dB.

Ordering Information

DTR - 266 - SM - XX -T- Ln

Receptacle

Blank: SC Receptacle
 ST : ST Receptacle
 FC : FC Receptacle

Temperature Range

Blank: $0^\circ C$ to $+70^\circ C$
 A : $-40^\circ C$ to $+85^\circ C$

Light Output Option

L0: - 3 dBm (typ.)
 L1: - 5 dBm (typ.)
 L2: - 8 dBm (typ.)
 L3: - 11 dBm (typ.)

OC-12/STM-4 Single Mode Transceiver: DTR-622-SM

Transmitter Performance Characteristics (over Operating Case Temperature, $V_{CC} = 4.75$ to $5.25V$)

Parameter		Symbol	Minimum	Typical	Maximum	Units
Data Rate		B	50	622	700	Mb/s
Average Optical Output Power (coupled into single mode fiber), 50% duty cycle	HP	P_o	- 3.0	- 1.0	+2.0	dBm
	L0		- 5.0	- 3.0	0	
	L1		- 8.0	- 5.0	- 2.0	
	L2		- 12.0	- 8.0	- 5.0	
	L3		- 15.0	- 11.0	- 8.0	
Extinction Ratio	SR & IR	P_{hi}/P_{lo}	8.2	-	-	dB
	LR1 & LR2		10	-	-	
Center Wavelength ¹	SR (Short Reach)	λ_c	1261	1310	1360	nm
	IR (Intermediate Reach)		1274	1310	1356	
	LR1 (Long Reach 1310 nm)		1293	1310	1334	
	LR2 (Long Reach 1550 nm)		1280	1310	1335	
			1480	1550	1580	
Spectral Width (RMS) ¹	SR (Short Reach)	$\Delta\lambda_{RMS}$	-	-	4.0	nm
	IR (Intermediate Reach)		-	-	2.5	
			-	-	4.0	
Spectral Width (-20 dB)	LR1 & LR2	$\Delta\lambda_{20}$	-	-	1.0	
Side Mode Suppression Ratio	LR1 & LR2	$SMSR$	30	-	-	dB
Optical Rise and Fall Time (10% to 90%)		t_r, t_f	-	0.5	1.0	ns
Optical Output Eye	compliant with Bellcore TR-NWT-000253 and ITU-T Recommendation G.957					

¹ For Intermediate Reach version, the Center Wavelength is either $1274 \text{ nm} \leq \lambda_c \leq 1356 \text{ nm}$ for $\Delta\lambda_{RMS} \leq 2.5 \text{ nm}$ or $1293 \text{ nm} \leq \lambda_c \leq 1334 \text{ nm}$ for $\Delta\lambda_{RMS} \leq 4.0 \text{ nm}$.

Receiver Performance Characteristics (over Operating Case Temperature, $V_{CC} = 4.75$ to $5.25V$)

Parameter		Symbol	Minimum	Typical	Maximum	Units
Data Rate		B	50	622	700	Mb/s
Receiver Sensitivity (10^{-10} BER) ¹		P_{min}	- 29.0	- 31.0	-	dBm
Maximum Input Optical Power (10^{-10} BER) ¹		P_{max}	- 7.0	0	-	dBm
Signal Detect Thresholds	Increasing Light Input	P_{sd+}	-	-	- 29.0	dBm
	Decreasing Light Input	P_{sd-}	- 45.0	-	-	
Signal Detect Hysteresis		-	0.5	1.5	-	dB
Signal Detect Timing Delay	Increasing Light Input	t_{sd+}	-	-	100	μs
	Decreasing Light Input	t_{sd-}	-	-	100	
Wavelength of Operation		λ	1100	-	1600	nm

¹ Specified in Average Optical Input Power and measured at 622 Mb/s and 1300 nm wavelength (1550 nm for LR2 option) with $2^{23}-1$ PRBS.

Ordering Information

DTR - 622 - SM - XX -T- Ln - DR

<p>Receptacle</p> <p>Blank: SC Receptacle ST : ST Receptacle FC : FC Receptacle</p>	<p>Temperature Range</p> <p>Blank: 0°C to +70°C A : - 40°C to +85°C</p>	<p>Light Output Option</p> <p>HP: - 1 dBm (typ.) L0: - 3 dBm (typ.) L1: - 5 dBm (typ.) L2: - 8 dBm (typ.) L3: - 11 dBm (typ.)</p>	<p>Distance Option</p> <p>specifies the range for Center Wavelength & Spectral Width to be compliant with SONET/SDH standard</p> <p>“Blank”: Short Reach (SR) IR : Intermediate Reach / S-4.1 LR1 : Long Reach 1310 nm / L-4.1 LR2 : Long Reach 1550 nm / L-4.2</p>
--	--	--	--

NOTES

- For full compliance with OC-12/STM-4 Intermediate Reach / S-4.1 standard, the DTR-622-SM-xx-T-L3-IR modules are recommended.
- For full compliance with OC-12/STM-4 Long Reach 1310 nm / L-4.1 standard, the DTR-622-SM-xx-T-HP-LR1 modules are recommended. They use DFB lasers to satisfy the requirement for Center Wavelength & Spectral Width.
- For full compliance with OC-12/STM-4 Long Reach 1550 nm / L-4.2 standard, the DTR-622-SM-xx-T-HP-LR2 modules are recommended. Both modules use DFB lasers. However, the DTR-622-SM-xx-A-HP-LR2 is specified only over - 25°C to +70°C.
- The LR1 & LR2 options are available only with DFB lasers and HP optical output power level.

DTR-xxx-SM

Transmitter Electrical Interface (over Operating Case Temperature Range)

Parameter	Symbol	Minimum	Typical	Maximum	Units
Input HIGH Voltage	V_{IH}	$V_{CC} - 1.165$	-	$V_{CC} - 0.700$	V
Input LOW Voltage	V_{IL}	$V_{CC} - 1.890$	-	$V_{CC} - 1.475$	V
Data Input Current - HIGH	I_H	-	-	350	μA
Data Input Current - LOW	I_L	-	-	250	μA

Receiver Electrical Interface (over Operating Case Temperature Range)

Parameter	Symbol	Minimum	Typical	Maximum	Units
Output HIGH Voltage	V_{OH}	$V_{CC} - 1.080$	-	$V_{CC} - 0.700$	V
Output LOW Voltage	V_{OL}	$V_{CC} - 1.950$	-	$V_{CC} - 1.595$	V
Output Current	I_O	-	-	25	mA

Electrical Power Supply Characteristics (over Operating Case Temperature Range)

Parameter		Symbol	Minimum	Typical	Maximum	Units	
Supply Voltage		V_{CC}	4.75	5.0	5.25	V	
Supply Current	TX	Fabry Perot lasers	$I_{CC,TX}$	-	100	130	mA
		DFB lasers		-	120	150	
	RX	622 Mb/s	$I_{CC,RX}$	-	90	120	mA
		all others		-	80	100	

Application Notes

Transmitter: When the DATA+ input is at logic HIGH and DATA- input is at logic LOW, the LD is ON; and vice versa. In single-ended applications, the unused input pin should be biased to $V_{CC} - 1.29$ V.

The transmitter incorporates an Average Power Control (APC) loop to stabilize the transmitter average optical output power against temperature variation. The APC loop always acts to keep the transmitter average optical output power at a constant value. Therefore, when the input data is all continuous “zeroes” or all continuous “ones”, the transmitter optical output power is a constant level equal to the nominal average optical output power (not at the “OFF” level or at the “ON” level).

Receiver: Both differential DATA+ and DATA- outputs are PECL levels requiring termination (50 ohms to $V_{CC} - 2$ volts or 510 ohms to GND is recommended). For optimum performance, both outputs should be terminated in the same manner, even if only one is used.

The Signal Detect circuit monitors the level of the incoming optical signal and generates a logic LOW signal when insufficient optical power is received. The SIGNAL DETECT output is PECL level requiring termination (510 ohms to GND is recommended).

Interface circuit: The power supply line should be well-filtered. All 0.1 μF power supply bypass capacitors should be as close to the DTR transceiver module as possible. The two front GRD posts should be connected to Circuit Ground or Chassis Ground. The termination resistors for the Transmitter should be close to the DTR transceiver module. The termination resistors for the Receiver should be close to the PHY or SERDES device (which receives the DATA outputs from the Receiver).

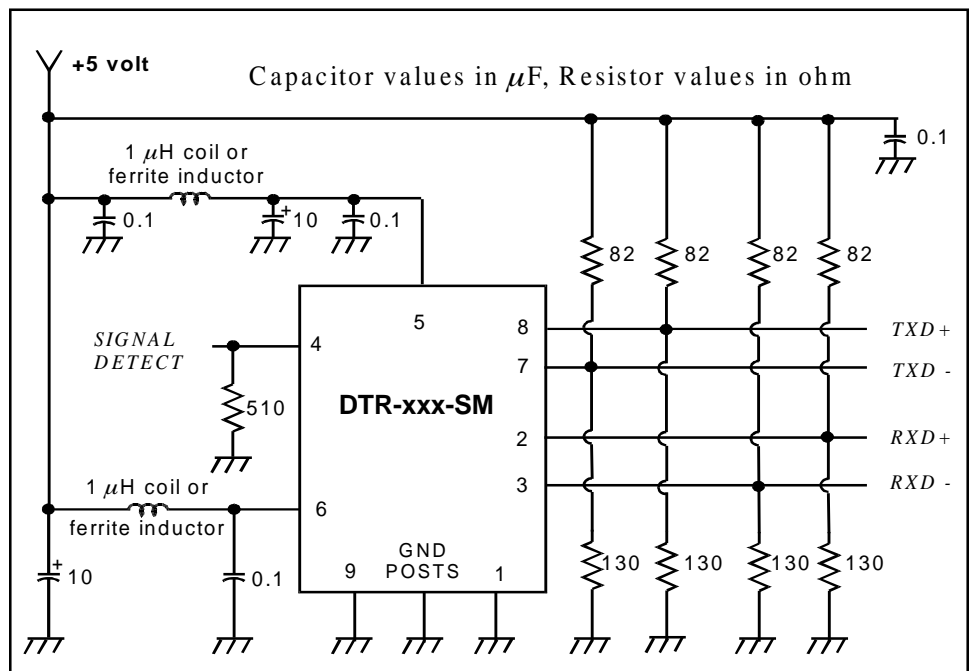

DTR-xxx-SM

Pin Assignments

PIN	FUNCTION
1	RX GND
2	RD+ (RX DATA OUT +)
3	RD- (RX DATA OUT -)
4	SD (RX SIGNAL DETECT)
5	V _{CC} RX
6	V _{CC} TX
7	TD- (TX DATA IN -)
8	TD+ (TX DATA IN +)
9	TX GND

Duplex SC Receptacle Package

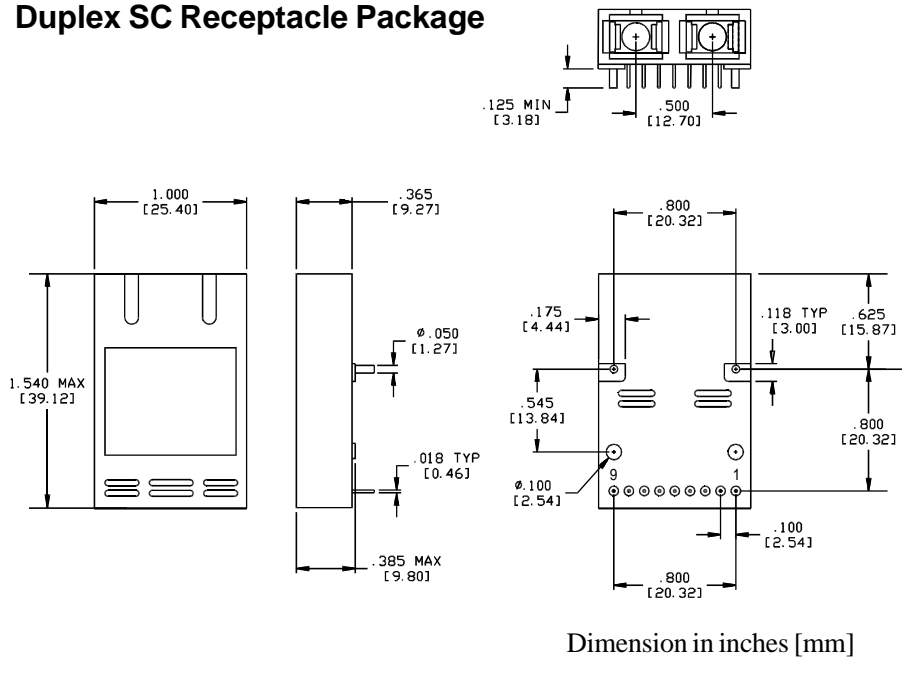

FC Receptacle Package

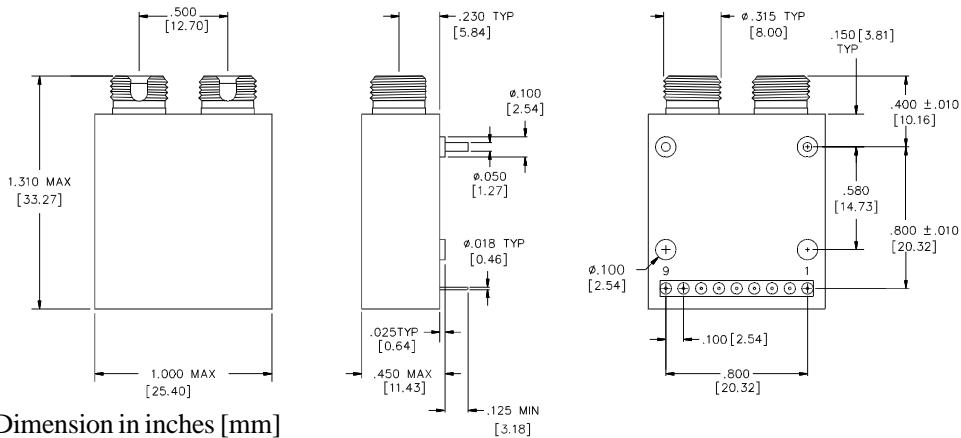

ST Receptacle Package

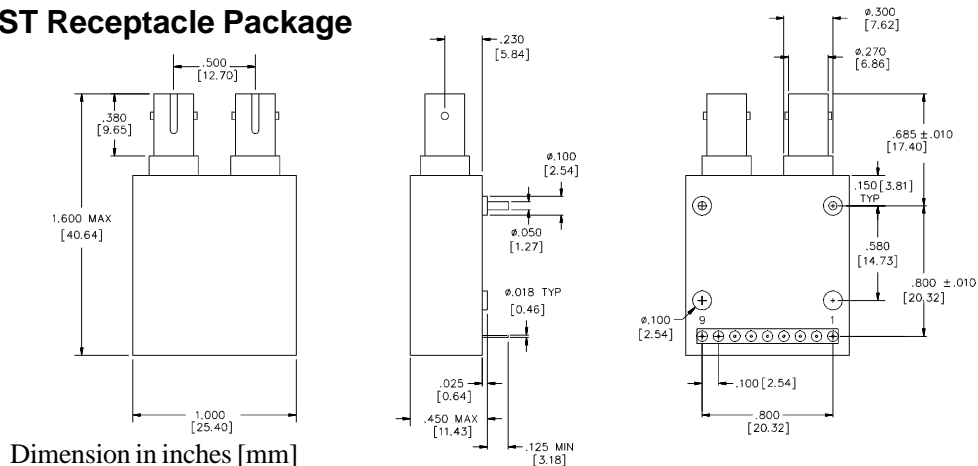

Laser Safety: All transmitters are Class I Laser products per FDA/CDRH and IEC-825 standards. They must be operated under specified operating conditions.

Optical Communication Products, Inc.

DATE OF MANUFACTURE:

MANUFACTURED IN THE USA

This product complies with
21 CFR 1040.10 and 1040.11

Meets Class I Laser Safety Requirements

Optical Communication Products, Inc.

9736 Eton Avenue, Chatsworth, CA 91311, Tel.: 818-701-0164, FAX: 818-701-1468

Optical Communication Products, Inc. reserves the right to make changes in equipment design or specifications without notice. Information supplied by Optical Communication Products, Inc. is believed to be accurate and reliable. However, no responsibility is assumed by Optical Communication Products, Inc. for its use nor for any infringements of third parties which may result from its use. No license is granted by implication or otherwise under any patent right of Optical Communication Products, Inc.

21737-0301, Rev. K

Contents

Description	1
Absolute Maximum Ratings	1
OC-1 Single Mode Transceiver: DTR-052-SM	2
FDDI Single Mode Transceiver: DTR-125-SM.....	3
OC-3/STM-1 Single Mode Transceiver: DTR-156-SM	4
266 Mb/s Fibre Channel Single Mode Transceiver: DTR-266-SM.....	5
OC-12/STM-4 Single Mode Transceiver: DTR-622-SM	6
Transmitter Electrical Interface (over Operating Case Temperature Range)	7
Receiver Electrical Interface (over Operating Case Temperature Range)	7
Electrical Power Supply Characteristics (over Operating Case Temperature Range)	7
Application Notes	7
Duplex SC Receptacle Package	8
FC Receptacle Package	8
ST Receptacle Package	8