

Purchase On-Line

www.datel.com

DATEL
INNOVATION and EXCELLENCE

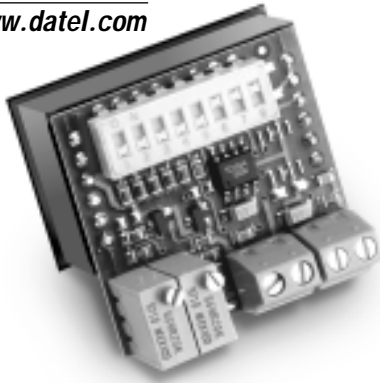

Actual Size

DMS-20PC-0/5

0-5V and 0-10V Input
3½ Digit, LED Display
Process Control Monitors

Features

- Accepts 0-5V and 0-10V inputs
- Large, easy-to-read, 0.37"/9.4mm LED display
- Choice of 5 LED power/color options
- High input impedance, 100k Ω
- +5V to +40V model draws 9mA typ.
- Miniature size: 1.38" x 1.25" x 0.95"
- High-quality, 20-turn, span (gain) and zero (offset) adjustments
- DIP-switch selectable range and decimal points
- Vibration-resistant package; Reliable screw-terminal input connections
- Hundreds of different input/readout combinations

DATEL's DMS-20PC-0/5 Series are the world's smallest, full-featured, 0-5V input process control monitors. Their large, easy-to-read, 0.37"/9.4mm LED displays are available in a choice of 4 LED color/intensity options: standard red, standard green, super-bright red, and low-power red. Two power supply input ranges are also available: the industry-standard +5V and a wide-range +5V to +40V (which typically draws 9mA at +24V).

Gain (span) and offset (zero) adjustments are performed with on-board, precision, 20-turn potentiometers. All decimal-point and range-change selections are made on an 8-position, vibration-resistant, gold-plated DIP switch. Unlike competitive meters, there are no jumpers or solder gaps to open or close, and to further enhance reliability, the entire assembly utilizes 100% soldered connections. Both power-supply and input-signal connections are made via reliable screw-type terminal blocks.

The DMS-20PC-0/5's DIP switch and potentiometers accommodate hundreds of input-voltage/output-reading combinations. This practically eliminates the need for more costly, long-lead-time, factory "specials" in applications which use several different-range meters. An accessory bezel assembly—featuring metal fasteners and a rubber gasket—simplifies panel mounting and also provides excellent resistance to environmental dust and moisture. All these outstanding features combine to make the DMS-20PC-0/5 the perfect meter for prototype and OEM, 0-5V input, process control monitoring.

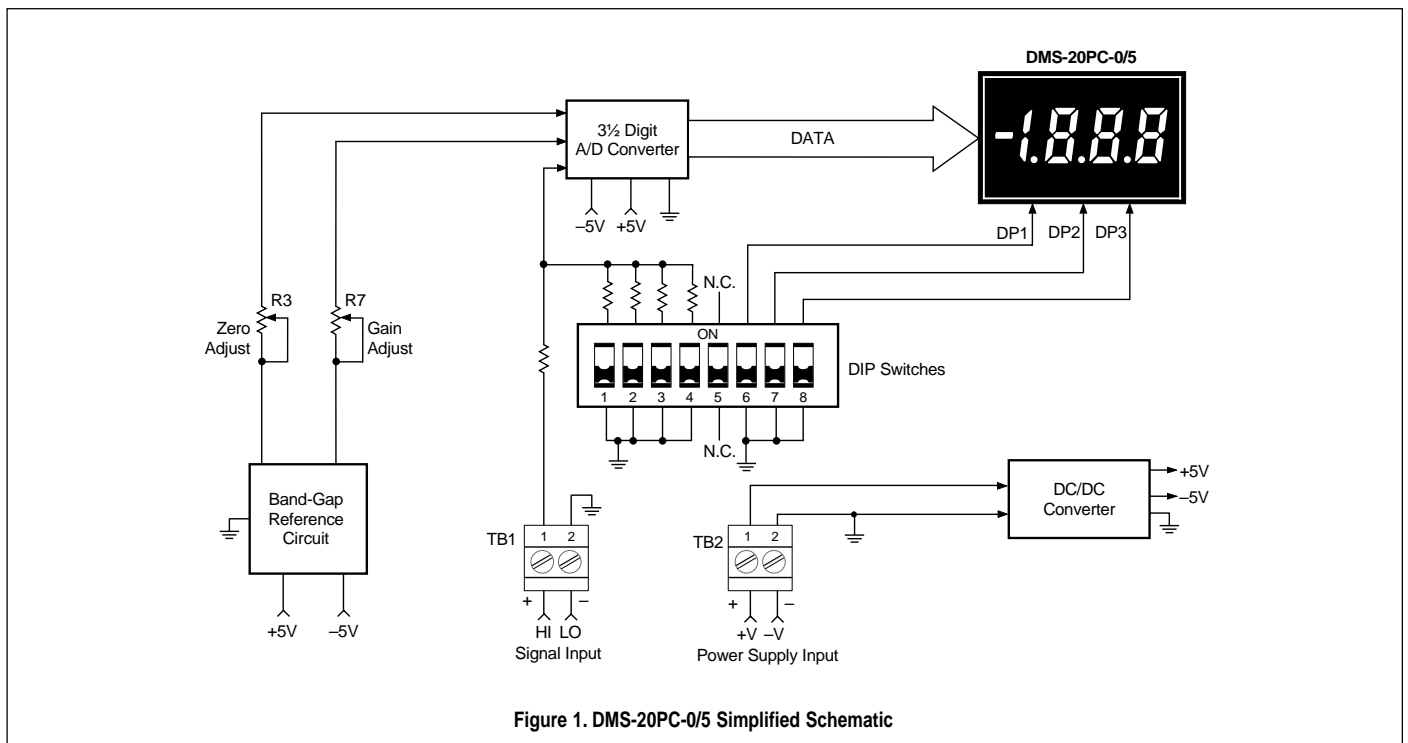

Figure 1. DMS-20PC-0/5 Simplified Schematic

Performance/Functional Specifications

Typical at T_A = +25°C, unless otherwise noted.

Input	Min.	Typ.	Max.	Units
Full Scale Input Range ①	4.9	5.0	5.1	Volts
Input Impedance	100	--	140	kΩ
Overvoltage Protection ①	--	--	±40	Volts
Performance				
Sampling Rate	2.5 samples per second			
Accuracy (1 minute warm-up)	±0.05%FS ±1 Count			
Temperature Drift (0 to +60°C)	—	±0.15	±0.3	Cnts/°C
Display				
Display Type and Size	3½ Digit LED, 0.37"/9.4mm high			
Polarity Indication	"—" for negative readings			
Overrange Indication	"-1___" for negative inputs "1___" for positive inputs			
Physical/Environmental				
Operating Temperature	0	—	+60	°C
Storage Temperature	-40	—	+75	°C
Humidity (Non-condensing)	0	—	95	%
Case Material	Polycarbonate			
Weight	0.6 ounces (17 grams)			
Power Supply Requirements				
DMS-20PC-0/5-5RS	+4.75V to +5.25V at 90mA max.			
DMS-20PC-0/5-5GS	+4.75V to +5.25V at 120mA max.			
DMS-20PC-0/5-5RL	+4.75V to +5.25V at 15mA max.			
DMS-20PC-0/5-5RH	+4.75V to +5.25V at 90mA max.			
DMS-20PC-0/5-24RL	+4.75V to +40V at 15mA max.			

① The DMS-20PC-0/5 can also be used in most 0-10V applications. See the section on 0-10V inputs for more information. See Note 3 on Table 1.

② INPUT LO (TB1 "-LO") is internally connected to the power return (TB2 "-V"). Overvoltage specifications apply to the INPUT HI (TB1 "+HI") connection.

Ordering Information

DMS-20PC-0/5-5RS	+5V supply, standard-intensity red LED's
DMS-20PC-0/5-5GS	+5V supply, standard-intensity green LED's
DMS-20PC-0/5-5RL	+5V supply, low-power red LED's
DMS-20PC-0/5-5RH	+5V supply, high-intensity red LED's
DMS-20PC-0/5-24RL	+5V to +40V supply, low-power red LED's
DMS-BZL3	Bezel assembly
DMS-BZL4	Bezel assembly with sealing gasket
DMS-20-CP	Panel cutout punch

Note: Standard panel-mount applications MUST use either DMS-BZL3 or DMS-BZL4 bezel assemblies. See Mechanical Specifications section for cutout/drill dimensions.

Order on-line at www.datel.com

Technical Notes

1. Input Configuration: The DMS-20PC-0/5 has its input low terminal (TB1 "LO") internally connected to the power supply ground terminal (TB2 "-V"). This connection effectively places the meter's input in a single-ended configuration. In some applications, single-ended inputs can cause ground-loop induced errors (the meter's display becomes unstable or bounces). This occurs because the LED drive currents flow through both the -V terminal and the signal LO terminal.

If suspected ground-loop errors are encountered, and the input signal LO terminal is externally connected to -V somewhere else in the system, try removing the connection to TB1 "LO". Inputs which have no ground-return connection to -V (commonly referred to as "floating inputs") must have their most negative potential tied to TB1 "LO". Please consult DATEL for more information.

Applications which require electrical isolation between the input signal source and the system power supply must use a separate transformer-isolated supply to power the meter.

2. Panel Mounting: In most standard through-the-panel installations, the DMS-20PC-0/5 must be secured to the panel with either DMS-BZL3 or DMS-BZL4 optional bezel assemblies (see the Mechanical Specifications section and the Ordering Guide for more information). The metal retaining clip supplied with other DMS-20 Series meters CAN NOT be used to support the DMS-20PC-0/5.

Operating and Setup Instructions

As shipped, the DMS-20PC-0/5 is factory calibrated to read "000" for a 0.0V input and "1999" for a 5.0V input. The following worst-case procedure assumes the DMS-20PC-0/5 is completely mis-adjusted, i.e., both potentiometers and the DIP switches are randomly set.

1. Set R7 (full scale span/gain adjust) and R3 (zero/offset adjust) fully clockwise, roughly 22 turns, and place SW1-SW8 to OFF (down position).
2. Select DIP switch setting #1 in Table 1.
3. Apply a precision 0.0V input and adjust R3 until the meter's display reads "000".
4. Apply a precision 5.0V input and adjust R7 until the meter's display reads "1999". Repeat steps 3 and 4 to make sure the adjustments do not affect one another.
5. Select the appropriate decimal point by setting SW6, SW7 or SW8 to ON (DP1, DP2 or DP3 respectively).

NOTE: The "000" to "1999" display readings referred to in the instructions above are for illustrative purposes only. If other display readings such as "000" to "1200" are desired, refer to the DIP-Switch Settings Tables for SW1-SW4 settings. (SW5 is reserved for future use, it has no affect on display operation.) The initial setting of R3 and R7 fully clockwise is recommended in the adjustment procedure for all the following examples.

Applications

Examples (0-5V Inputs)

1. Desired display readings are:

0.0V input = "0.00"
5.0V input = "6.00"

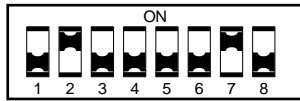

Use DIP-switch setting #3 in Table 1 and enable decimal point DP2 via SW7. Apply 0.0V and adjust R3 so the display reads "0.00". Apply 5.0V and adjust R7 so the display reads "6.00".

2. Desired display readings are:

0.0V input = "000"
5.0V input = "800"

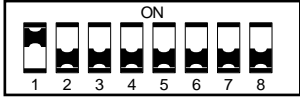

Use DIP-switch setting #2 in Table 1. Apply 0.0V and adjust R3 so the display reads "000". Apply 5.0V and adjust R7 so the display reads "800". For these display readings, no decimal points are used. Set SW6, SW7 and SW8 to OFF.

3. Desired display readings are:

0.0V input = ".000"
5.0V input = ".250"

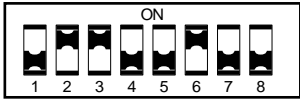

Use DIP-switch setting #5 in Table 1 and enable decimal point DP1 via SW6. Apply 0.0V and adjust R3 so the display reads "000". Apply 5.0V and adjust R7 so the display reads ".250".

4. Desired display readings are:

1.0V input = "000"
6.0V input = "090"

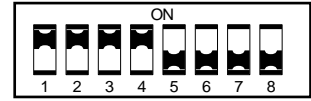

Even though this input is positioned between +1.0V and +6.0V, it still meets the 5V full scale input range listed in the Functional Specifications section. Use DIP-switch setting #8 in Table 1. Apply 1.0V and adjust R3 so the display reads "000". Apply 6.0V and adjust R7 so the display reads "090". With this type of input, it is advisable to recheck both input levels to be sure the potentiometer settings do not affect one another.

0-10V Inputs

While the DMS-20PC-0/5 is optimized for operation with 0-5V inputs, its versatile input stage can also accommodate most 0-10V applications. The meter's zero/offset potentiometer (R3) has enough adjustment range to produce a "000" display reading with input signal levels between -0.1V and +1.0V. Table 2. summarizes the available ranges when the DMS-20PC-0/5 is used with 0-10V inputs.

Example (0-10V Inputs)

1. Desired display readings are:

0.0V input = "000"
10.0V input = "500"

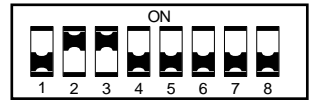

Use DIP switch setting #4 in Table 2. Apply 0.0V and adjust R3 so the display reads "000". Apply 10.0V and adjust R7 so the display reads "500".

Table 1. 0-5V DIP-Switch Settings ③

Display Reading		SW1	SW2	SW3	SW4
0.0V Input	5.0V Input				
1. 000	1200-1999	Off	Off	Off	Off
2. 000	700-1200	On	Off	Off	Off
3. 000	400-700	Off	On	Off	Off
4. 000	300-400	Off	Off	On	Off
5. 000	190-300	Off	On	On	Off
6. 000	120-190	Off	Off	On	On
7. 000	100-150	Off	On	On	On
8. 000	90-140	On	On	On	On

③ The DMS-20PC-0/5 is optimized for handling 5V signal ranges that are positioned between -0.1V and +6.0V. As such, input ranges can be anywhere between -0.1V to +4.9V and +1.0V to +6.0V as long as their full range is 5 Volts. The meter's zero/offset potentiometer (R3) has enough adjustment range to produce a "000" display reading for input signal levels between -0.1V and +1.0V.

Please note the DMS-20PC digital panel meter from which the DMS-20PC-0/5 is derived has an accuracy specification of ±2 counts (max.). Thus, it may not always be possible to obtain the exact desired display readings.

Table 2. 0-10V DIP-Switch Settings

Display Reading		SW1	SW2	SW3	SW4
0.0V Input	10.0V Input				
1. 000	1400-1999	On	Off	Off	Off
2. 000	800-1400	Off	On	Off	Off
3. 000	600-800	Off	Off	On	Off
4. 000	380-600	Off	On	On	Off
5. 000	240-380	Off	Off	On	On
6. 000	200-300	Off	On	On	On
7. 000	180-280	On	On	On	On

Mechanical Specifications

MECHANICAL DIMENSIONS: Inches (mm)
 TOLERANCES: 2 PL DEC ±0.02 (±0.51)
 3 PL DEC ±0.010 (±0.254)
 WIRE SIZE: 18 to 26 AWG
 (Solid or stranded)
 STRIPPING LENGTH: 0.20" (5.08mm)

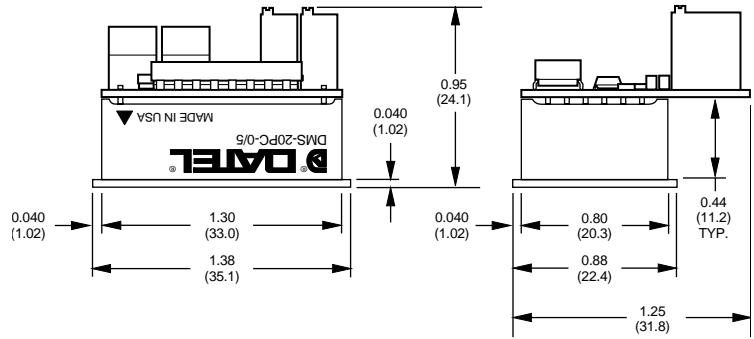

Back View

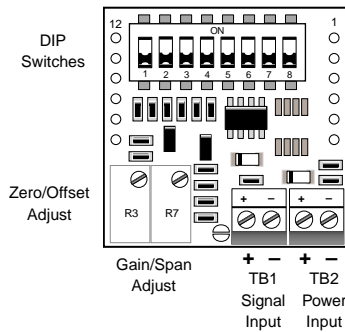

Front View

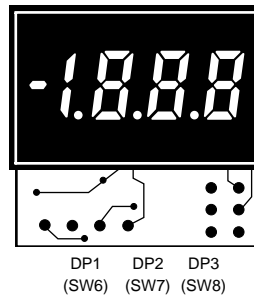

OPTIONAL BEZEL (DMS-BZL3 and DMS-BZL4)

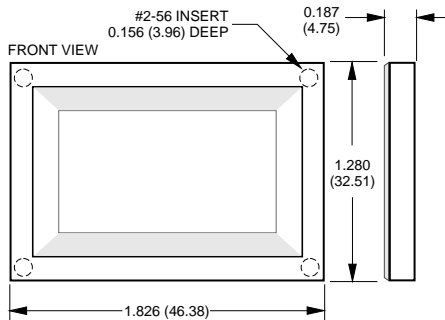

RECOMMENDED DRILL AND PANEL CUTOUT DIMENSIONS

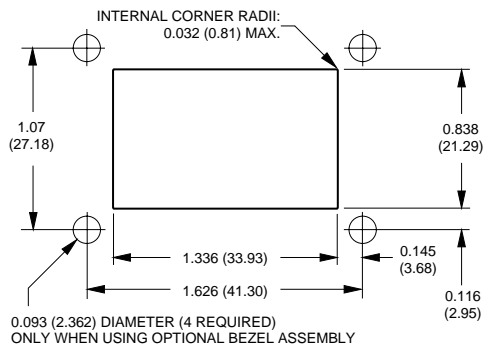

BEZEL INSTALLATION

