

LED Panel Display

■ Absolute Maximum Ratings(Mold Type) Figures shown below are values per chip.

(Ta=25°C)

Type	Radiation size (mm)	Radiation color			Model No.	Power dissipation ¹ P (mW)	Forward current I _F (mA)	Peak forward current ² I _{FM} (mA)	Derating factor (mA/°C)		Reverse voltage V _R (V)	Operating temperature T _{opr.} (°C)	Storage temperature T _{stg.} (°C)
		Red	Yellow	Yellow-green					DC	Pulse			
Case mold	7.0×9.0	●			LT9002D	168	30	50	0.55	0.91	5	-20 to +70	-30 to +80
			●		LT9002H	100	20	50	0.36	0.91	5	-20 to +70	-30 to +80
				●	LT9002E	170	30	50	0.55	0.91	5	-20 to +70	-30 to +80
	7.0×19.0	●		●	LT9002ED	84	30	50	0.55	0.91	5	-20 to +70	-30 to +80
		●			LT9010D	252	30	50	0.55	0.91	5	-20 to +70	-30 to +80
			●		LT9010H	150	20	50	0.36	0.91	5	-20 to +70	-30 to +80
Built-in reflector mold	4.0×10.0			●	LT9010E	252	30	50	0.55	0.91	5	-20 to +70	-30 to +80
		●			LT9200D	168	30	50	0.55	0.91	5	-20 to +70	-30 to +80
			●		LT9200H	100	20	50	0.36	0.91	5	-20 to +70	-30 to +80
	11.4×13.9	●			LT9210D	336	30	50	0.55	0.91	5	-20 to +70	-30 to +80
			●		LT9210H	200	20	50	0.36	0.91	5	-20 to +70	-30 to +80
				●	LT9210E	336	30	50	0.55	0.91	5	-20 to +70	-30 to +80
	13.0×17.0	●			LT9220D	336	30	50	0.55	0.91	5	-20 to +70	-30 to +80
			●		LT9220H	200	20	50	0.36	0.91	5	-20 to +70	-30 to +80
				●	LT9220E	336	30	50	0.55	0.91	5	-20 to +70	-30 to +80
	7.0×16.0	●			LT9230D	252	30	50	0.55	0.91	5	-20 to +70	-30 to +80
			●		LT9230H	150	20	50	0.36	0.91	5	-20 to +70	-30 to +80
	Thin case mold	18.0×45.0	●			LT9310D	168	30	50	0.55	0.91	5	-20 to +70
			●		LT9310H	100	20	50	0.36	0.91	5	-20 to +70	-30 to +80
				●	LT9310E	168	30	50	0.55	0.91	5	-20 to +70	-30 to +80
13.1×65.0		●			LT9323D	504	30	50	0.55	0.91	5	-20 to +70	-30 to +80
			●		LT9323H	504	30	50	0.55	0.91	5	-20 to +70	-30 to +80
				●	LT9323E	504	30	50	0.55	0.91	5	-20 to +70	-30 to +80
13.5×102.0		●			LT9330D	840	30	50	0.55	0.91	5	-20 to +70	-30 to +80
			●		LT9330H	840	30	50	0.55	0.91	5	-20 to +70	-30 to +80
				●	LT9330E	840	30	50	0.55	0.91	5	-20 to +70	-30 to +80
Insert mold	7.0×9.0	●			LT9400D	336	30	50	0.55	0.91	5	-20 to +70	-30 to +80
				●	LT9400E	336	30	50	0.55	0.91	5	-20 to +70	-30 to +80
		●		●	LT9400ED	168	30	50	0.55	0.91	5	-20 to +70	-30 to +80

*1 Per dot

*2 Duty ratio=1/10, Pulse width=0.1ms

LED Panel Display

■ Electro-optical Characteristics(Mold Type) Figures shown below are values per chip.

(Ta=25°C)

Type	Radiation size (mm)	Radiation color			Model No.	Forward voltage V _F (V)		Luminous intensity ^{*1} I _v (mcd)	Peak emission wavelength λ _p (nm)	Spectrum radiation bandwidth Δλ(nm)		Reverse current I _R (μA)		
		Red	Yellow	Yellow- green		TYP.	MAX.			TYP.	TYP.	I _F (mA)	MAX.	V _R (V)
Case mold	7.0×9.0	●			LT9002D	2.0	2.8	10.0	635	35	20	10	4	
			●		LT9002H	1.9	2.5	15.0	585	30	10	10	4	
				●	LT9002E	2.1	2.8	20.0	565	30	20	10	4	
	7.0×19.0	●		●	LT9002ED ²	2.1/2.0	2.8/2.8	20.0/15.0	565/635	30/35	20	10	4	
		●			LT9010D	2.0	2.8	15.0	635	35	20	10	4	
			●		LT9010H	1.9	2.5	20.0	585	30	10	10	4	
Built-in reflector mold	4.0×10.0	●			LT9200D	2.0	2.8	9.5	635	35	20	10	4	
			●		LT9200H	1.9	2.5	4.0	585	30	10	10	4	
	11.4×13.9	●			LT9210D	2.0	2.8	40.0	635	35	20	10	4	
			●		LT9210H	1.9	2.5	9.0	585	30	10	10	4	
				●	LT9210E	2.1	2.8	45.0	565	30	20	10	4	
	13.0×17.0	●			LT9220D	2.0	2.8	70.0	635	35	20	10	4	
			●		LT9220H	1.9	2.5	20.0	585	30	10	10	4	
				●	LT9220E	2.1	2.8	45.0	565	30	20	10	4	
	7.0×16.0	●			LT9230D	2.0	2.8	25.0	635	35	20	10	4	
			●		LT9230H	1.9	2.5	20.0	585	30	10	10	4	
	Thin case mold	18.0×45.0	●			LT9310D	2.0	2.8	24.0	635	35	20	10	4
				●		LT9310H	1.9	2.5	6.0	585	30	10	10	4
				●	LT9310E	2.1	2.8	26.0	565	30	20	10	4	
13.1×65.0		●			LT9323D	2.0	2.8	8.0 ^{*3}	635	35	20	10	4	
			●		LT9323H	2.0	2.8	8.5 ^{*3}	585	30	20	10	4	
				●	LT9323E	2.1	2.8	11.0 ^{*3}	565	30	20	10	4	
13.5×102.0		●			LT9330D	2.0	2.8	100.0	635	35	20	10	4	
			●		LT9330H	2.0	2.8	70.0	585	30	20	10	4	
				●	LT9330E	2.1	2.8	170.0	565	30	20	10	4	
Insert mold	7.0×9.0	●			LT9400D	2.0	2.8	52.0	635	35	20	10	4	
				●	LT9400E	2.1	2.8	70.0	565	30	20	10	4	
		●		●	LT9400ED ²	2.1/2.0	2.8/2.8	43/35	565/635	30/35	20	10	4	

*1 Per dot

*2 Each figure shown in the table is yellow-green/red.

*3 L_v(mcd/cm²)

(Notice) ● In the absence of confirmation by device specification sheets, SHARP takes no responsibility for any defects that may occur in equipment using any SHARP devices shown in catalogs, data books, etc. Contact SHARP in order to obtain the latest device specification sheets before using any SHARP device.

(Internet) ● Data for sharp's optoelectronic/power device is provided for internet.(Address <http://www.sharp.co.jp/ecg/>)

LED Panel Displays Characteristics Diagrams

D series

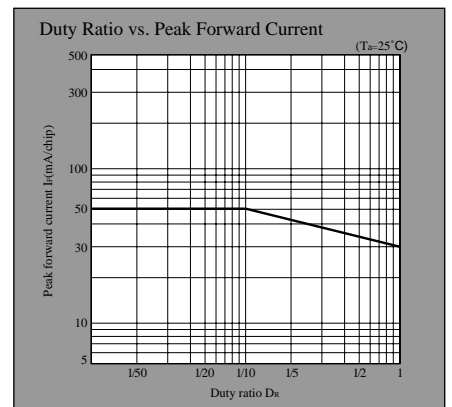
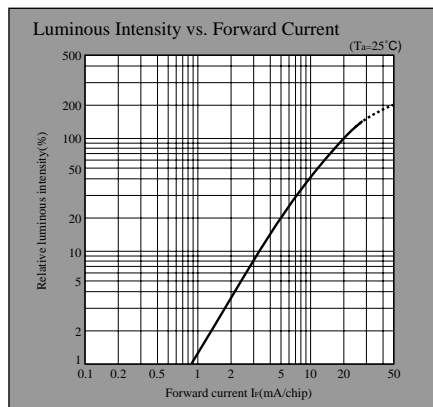
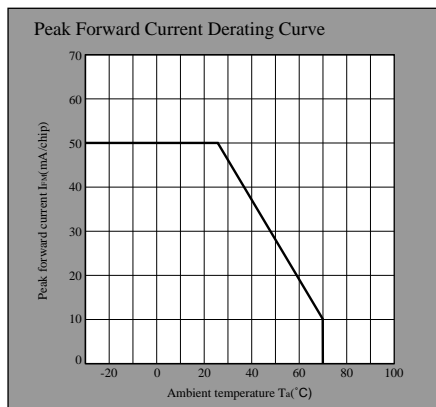
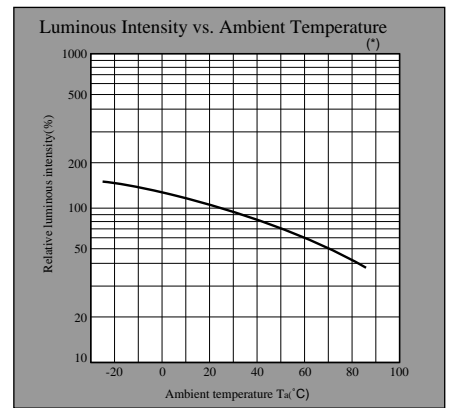
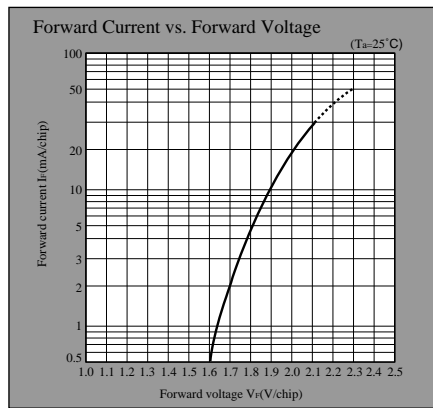
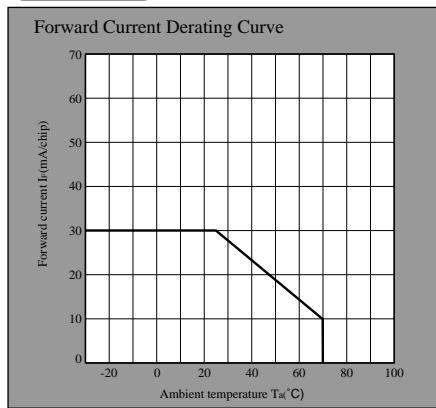

* As for current conditions, refer to I_f in electro-optical characteristics

H/E series

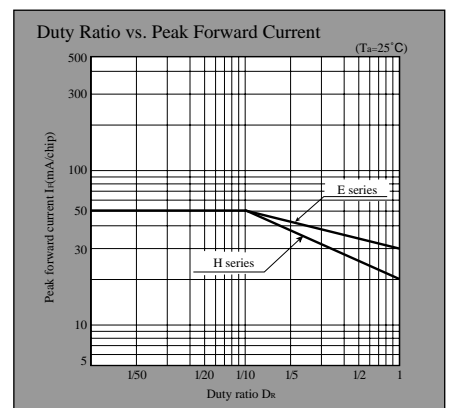
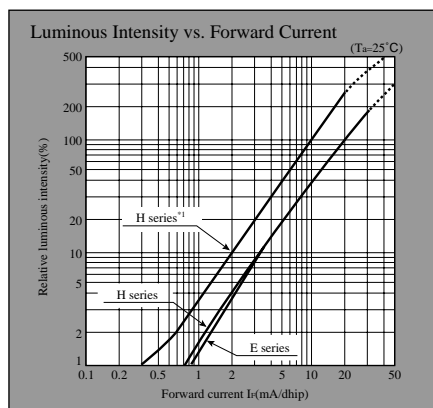
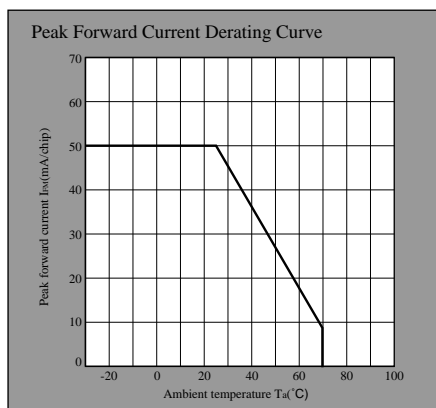
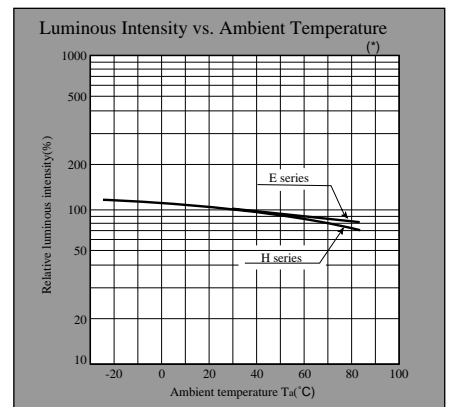
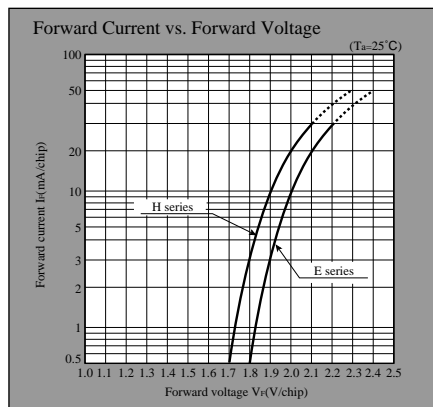
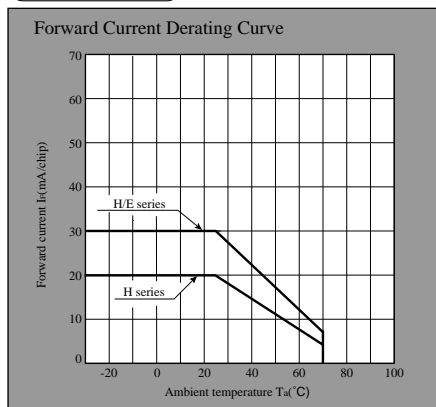

* As for current conditions, refer to I_f in electro-optical characteristics *H series $I_f=10\text{mA}$

LED Panel Display Outline Dimensions(Unit:mm)

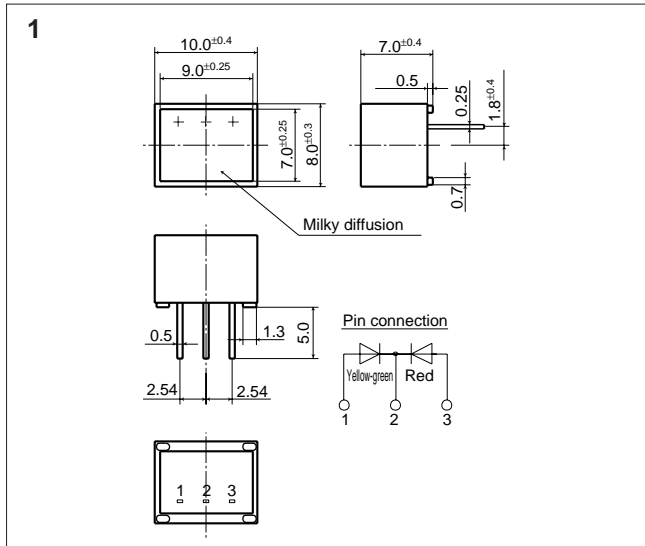

LT9002ED(Dichromatic emission)

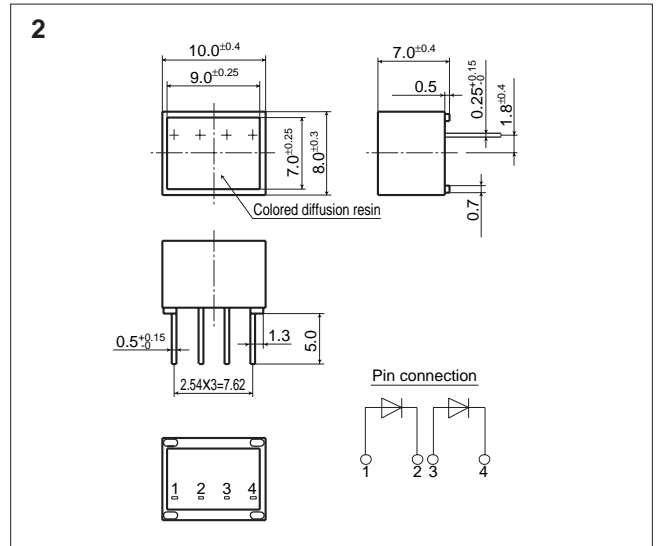

LT9002□ Series(Single color emission)

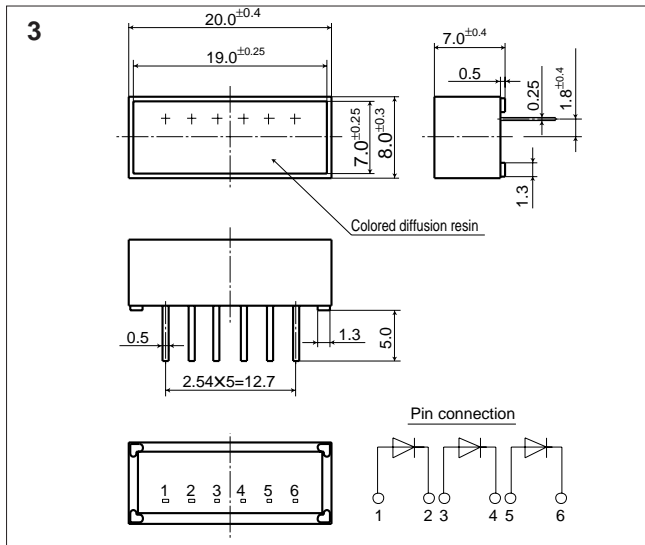

LT9010□ Series

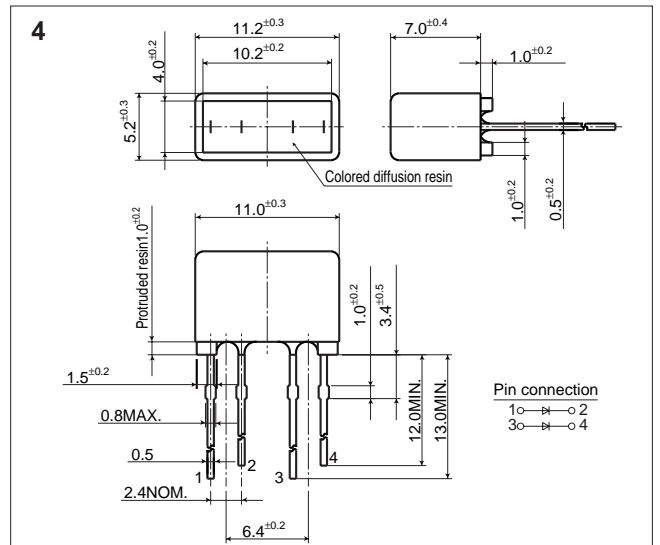

LT9200□ Series

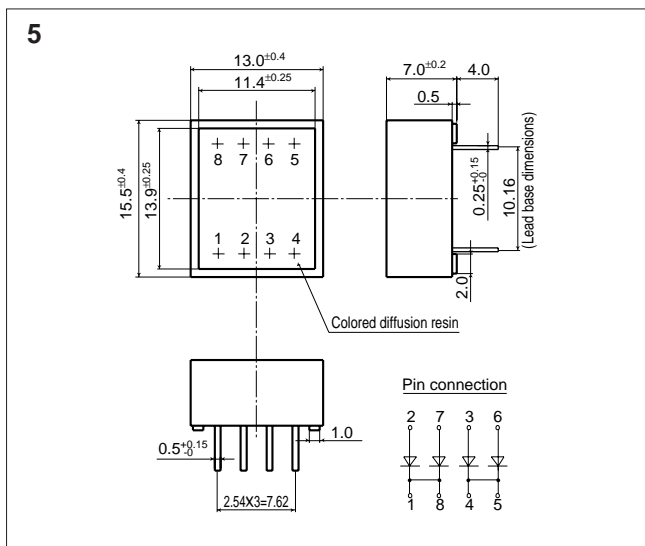

LT9210□ Series

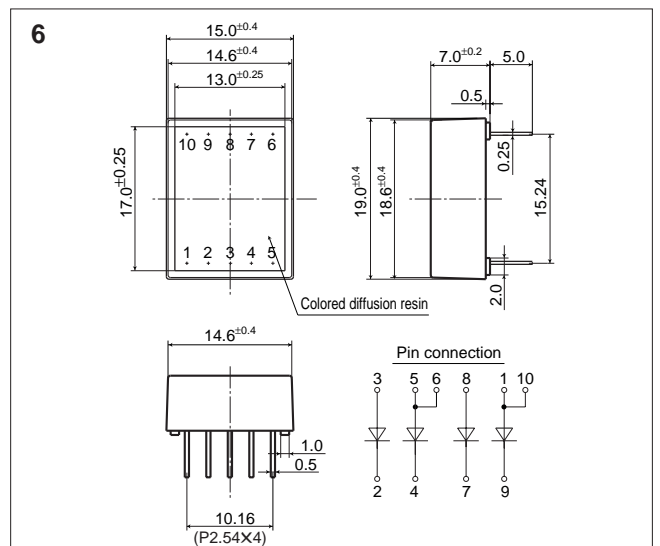

LT9220□ Series

(Notice) • In the absence of confirmation by device specification sheets, SHARP takes no responsibility for any defects that may occur in equipment using any SHARP devices shown in catalogs, data books, etc. Contact SHARP in order to obtain the latest device specification sheets before using any SHARP device.
 (Internet) • Data for sharp's optoelectronic/power device is provided for internet.(Address <http://www.sharp.co.jp/ecg/>)

LED Panel Display Outline Dimensions(Unit:mm)

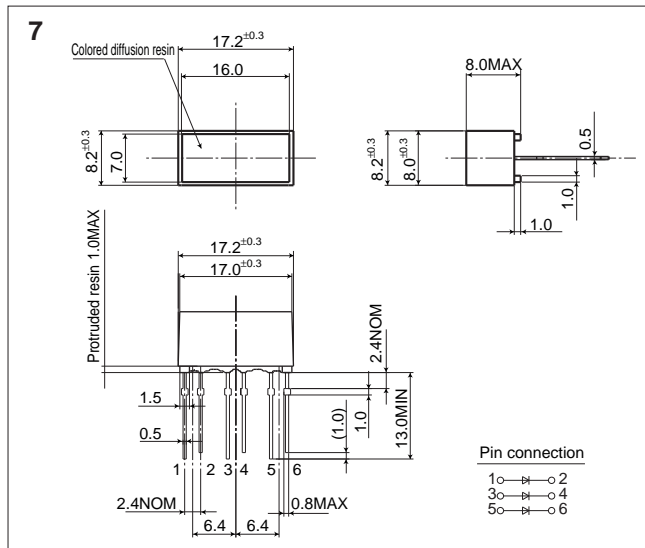

LT9230□ Series

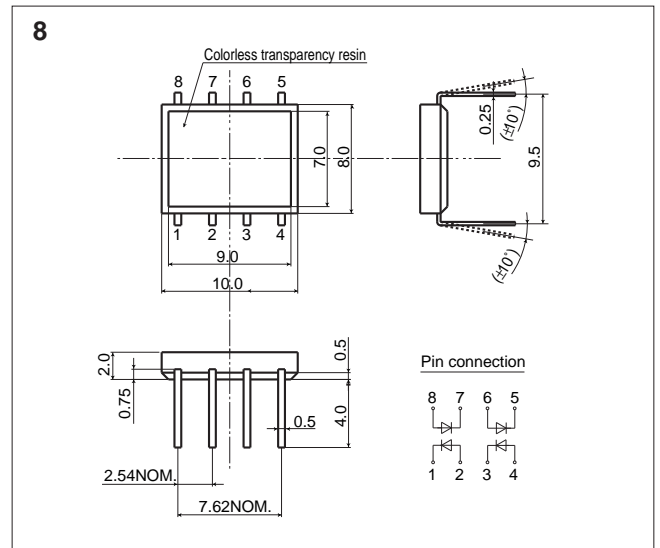

LT9400□ Series,LT9400ED

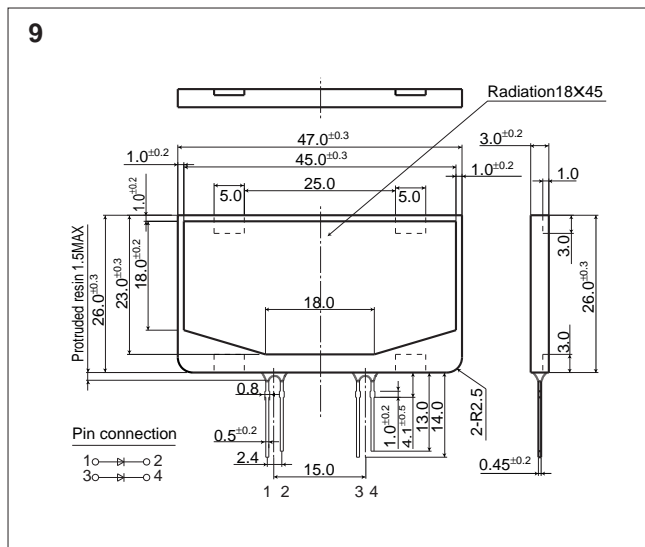

LT9310□ Series

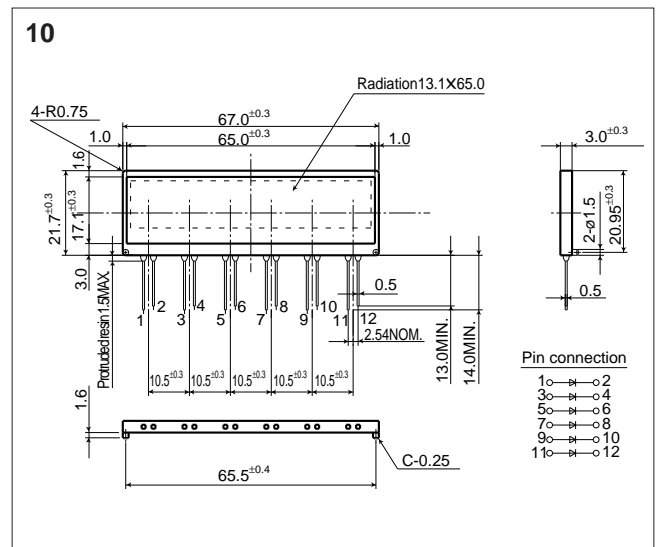

LT9323□ Series

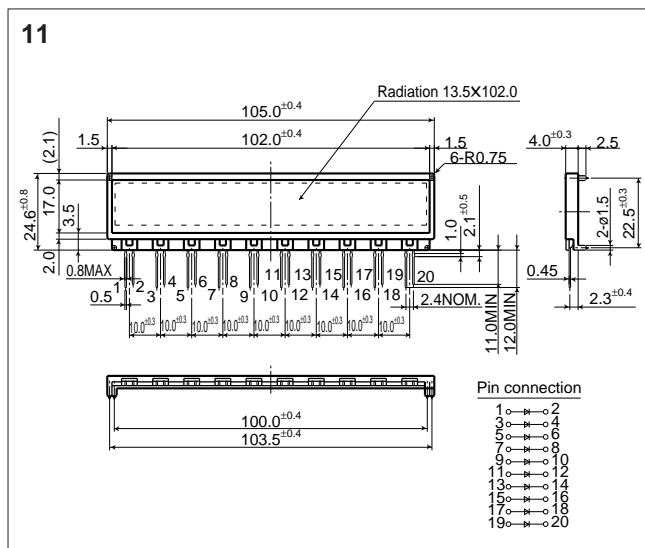

LT9330□ Series

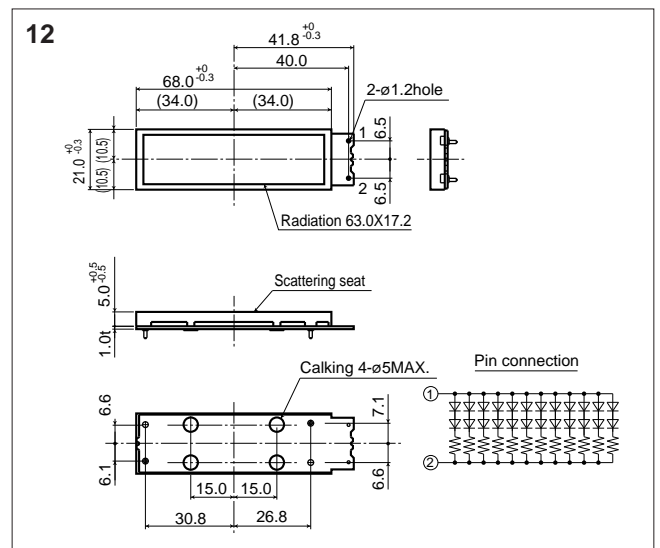

LT4082□ Series

(Notice) • In the absence of confirmation by device specification sheets, SHARP takes no responsibility for any defects that may occur in equipment using any SHARP devices shown in catalogs, data books, etc. Contact SHARP in order to obtain the latest device specification sheets before using any SHARP device.
 (Internet) • Data for sharp's optoelectronic/power device is provided for internet.(Address <http://www.sharp.co.jp/ecg/>)