

1.5A Low Dropout Positive Adjustable Regulator

Advanced Information

SOT-223

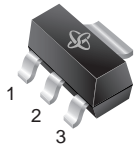

GS1086CST

TO-252 (DPak)

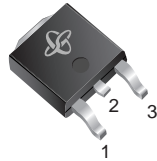

GS1086CE

TO-220AB

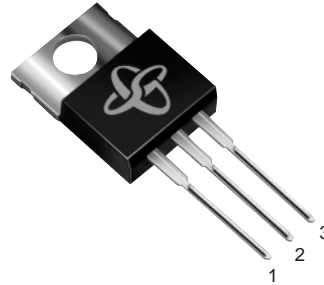

GS1086CT

TO-263AB (D²Pak)

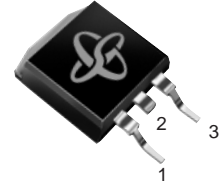

GS1086CM

Pin Definition

1. Adjust/Gnd.
2. V_{out} (tab)
3. V_{in}

Features

- Dropout Voltage 1.3V at 1.5A Output Current
- Fast Transient Response
- Line Regulation typically at 0.015%
- Load Regulation typically at 0.1%
- Internal thermal and current limiting
- Adjustable Output Voltage or Fixed 2.85V, 3.3V, 5V
- Standard 3-Pin Power Packages

Functional Block Diagram

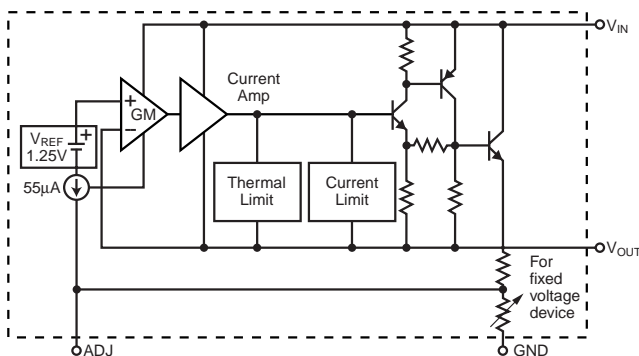

Description

The GS1086 is a low dropout three terminal regulator with 1.5A output current capability. The output voltage is adjustable with the use of a resistor divider. For fixed output voltage versions, the output voltage is internally set at 2.85V, 3.3V or 5V. Dropout is guaranteed at a maximum of 1.5V at maximum output current. Its low dropout voltage and fast transient response make it ideal for low voltage microprocessor applications. Internal current and thermal limiting provides protection against any overload condition that would create excessive junction temperatures.

Applications

- Post Regulator for Switching Supply
- Battery Chargers
- Constant-Current Regulators
- PC Add-On Card

Mechanical Data

Case: TO-220AB, TO-263AB (D²PAK), TO-252 (DPAK) and SOT-223

High temperature soldering guaranteed:
260°C/10 seconds at terminals

Case outlines are on the back page

1.5A Low Dropout Positive Adjustable Regulator

Maximum Ratings and Thermal Characteristics (T_A = 25°C unless otherwise noted)

Parameter	Symbol	Value	Unit
Vin Pin to ADJ/GND Pin	V _{in}	7	V
Thermal Resistance – Junction to Case	R _{θJC}	TO-220AB	3.0
		TO-252	12.5
		TO-263AB	3.0
		SOT-223	15.0
Operating Junction Temperature Range	T _J	0 to +125	°C
Storage Temperature Range	T _{stg}	-65 to 150	°C

Electrical Characteristics ⁽¹⁾ T_J = 25°C ⁽²⁾, V_{IN} = 5V, I_o = 10mA unless otherwise noted.

Parameter	Symbol	Test Conditions	Min	Typ	Max	Unit
Reference Voltage	V _{REF}	T _J = 25°C	1.238	1.250	1.262	V
		0°C ≤ T _J ≤ 125°C 2.65V ≤ V _{IN} ≤ 7V 10mA ≤ I _o ≤ 1.5A	1.225	1.250	1.275	V
Output Voltage	V _{OUT}	GS1086-2.85, V _{IN} = 5V	2.82	2.85	2.88	V
		GS1086-3.3, V _{IN} = 5V	3.26	3.30	3.33	V
		GS1086-5, V _{IN} = 7V	4.95	5.00	5.05	V
		GS1086	0.98V _N	V _N	1.02V _N	V
		0°C ≤ T _J ≤ 125°C 2.65V ≤ V _{IN} ≤ 7V 10mA ≤ I _o ≤ 1.5A				
Line Regulation	REG _{line}	2.65V ≤ V _{IN} ≤ 7V		0.015	0.2	% V _O
		T _J = 25°C 0°C ≤ T _J ≤ 125°C		0.02	0.2	% V _O
Load Regulation	REG _{load}	10mA ≤ I _o ≤ 1.5A		0.1	0.3	% V _O
		T _J = 25°C 0°C ≤ T _J ≤ 125°C		0.2	0.4	% V _O
Dropout Voltage	V _{DROP}	0°C ≤ T _J ≤ 125°C				
		I _o = 1.5A		1.3	1.5	V
		I _o = 1.0A		1.25	1.45	V
		I _o = 500mA		1.2	1.4	V

Notes:

(1) All parameters, except nominal output voltage are specified for the variable voltage version, allowing a wider V_{in} Range.

The specified limits also apply for the fixed voltage versions over the allowable input voltage range: GS1086-2.85 (4.25V - 7.0V), GS1086-3.3 (4.75V - 7.0V), GS1086-5 (6.4V - 7.0V).

(2) To maintain the specified junction temperatures, low duty cycle pulse testing is required for most parameters.

1.5A Low Dropout Positive Adjustable Regulator

Electrical Characteristics ⁽¹⁾ $T_J = 25^\circ\text{C}$, ⁽²⁾ $V_{IN} = 5\text{V}$, $I_o = 10\text{mA}$ unless otherwise noted.

Parameter	Symbol	Test Conditions	Min	Typ	Max	Unit
Output Current	I_o	$0^\circ\text{C} \leq T_J \leq 125^\circ\text{C}$	1.5	2.0		A
Adjust Pin Current	I_{adj}	$2.65 \leq V_{in} \leq 7\text{V}$ $10\text{mA} \leq I_o \leq 1.5\text{A}$ $0^\circ\text{C} \leq T_J \leq 125^\circ\text{C}$		55	120	μA
Adjust Pin Current Change	ΔI_{adj}	$2.65 \leq V_{in} \leq 7\text{V}$ $10\text{mA} \leq I_o \leq 1.5\text{A}$ $0^\circ\text{C} \leq T_J \leq 125^\circ\text{C}$		0.2	5	μA
Temperature Stability	T_S	$I_o = 0.5\text{A}$ $0^\circ\text{C} \leq T_J \leq 125^\circ\text{C}$		0.8		$\%V_o$
Minimum Load Current Adjustable Version	I_{LMIN}	$0^\circ\text{C} \leq T_J \leq 125^\circ\text{C}$		3	10	mA
Quiescent Current Fixed Voltage Version	I_Q	$0^\circ\text{C} \leq T_J \leq 125^\circ\text{C}$		10	14	mA
RMS Output Noise	N	$10\text{Hz} \leq f \leq 10\text{kHz}$		0.003		$\%V_o$
Ripple Rejection Ratio	RR	$f = 120\text{Hz}$, $C_o = 25\mu\text{F}$ $C_{adj} = 25\mu\text{F}$	60	68		dB
Thermal Regulation	R_{TH}	$T_A = 25^\circ\text{C}$, 30ms Pulse		0.02	0.05	$\%/W$
Long Term Stability		$T_A = 125^\circ\text{C}$, 1000 Hrs		0.3		$\%V_o$

Notes:

- (1) All parameters, except nominal output voltage are specified for the variable voltage version, allowing a wider V_{in} Range. The specified limits also apply for the fixed voltage versions.
- (2) To maintain the specified junction temperatures, low duty cycle pulse testing is required for most parameters.

Typical Application Circuit

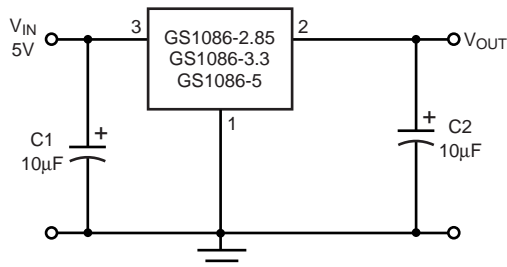

Fixed Voltage Regulator

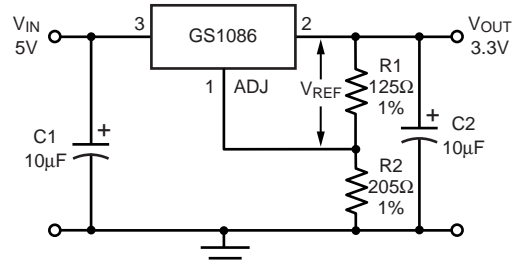

Adjustable Voltage Regulator

Notes:

- $V_{REF} = V_{OUT} - V_{ADJ} = 1.25\text{V}$ (typ.)
- $V_{OUT} = V_{REF} \times (1 + R2/R1) + I_{ADJ} \times R2$
- $I_{ADJ} = 55\mu\text{A}$ (typ.)
- (1) C1 needed if device is far away from filter capacitors
- (2) C2 required for stability

Ratings and Characteristic Curves (T_A = 25°C unless otherwise noted)

1.5A Low Dropout Positive Adjustable Regulator

Fig. 1 – Dropout Voltage (V_{OUT} = 3.3V)

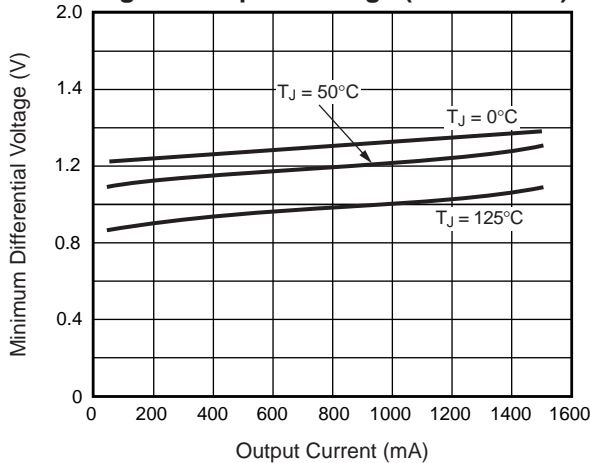

Fig. 2 – Dropout Voltage v.s. Temperature

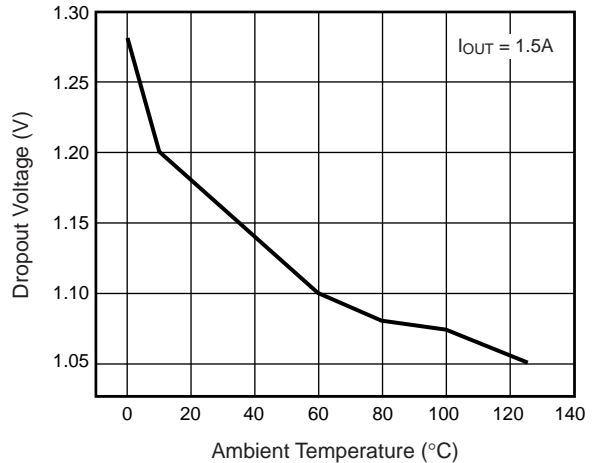

Fig. 3 – Minimum Load Current (Adjustable Version)

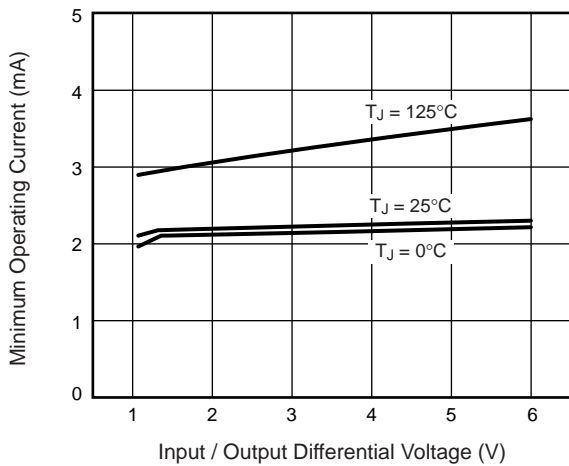

Fig. 4 – Adjust Pin Current

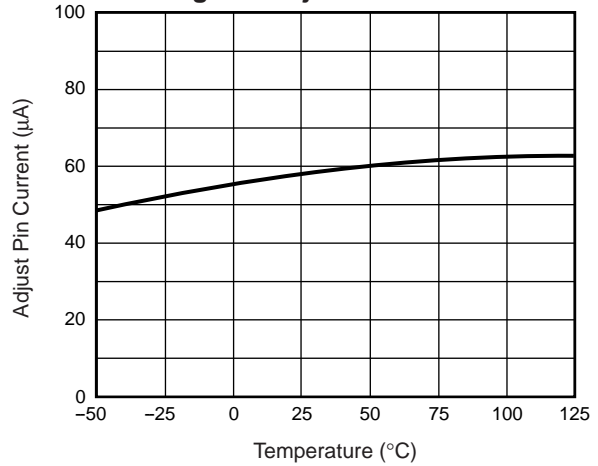

Fig. 5 – Temperature Stability

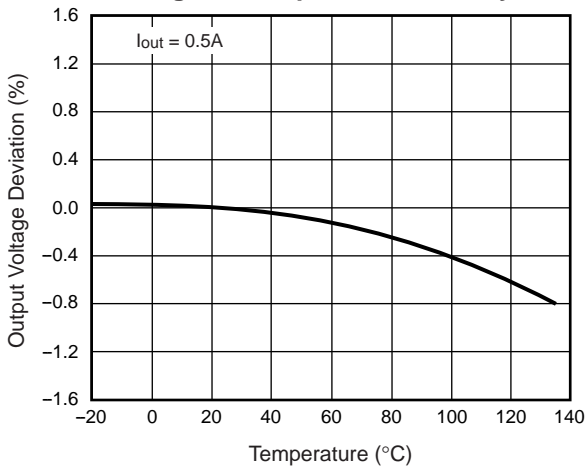
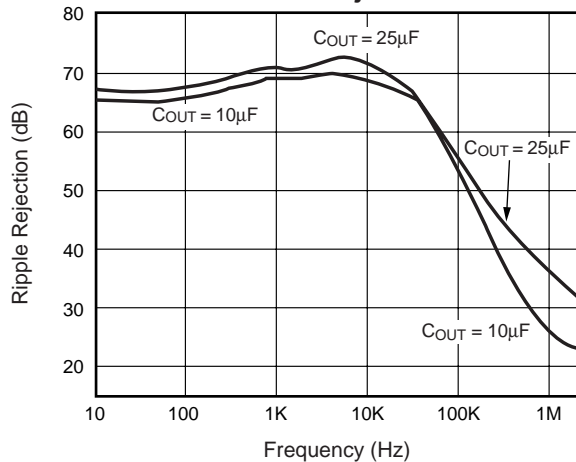

Fig. 6 – Ripple Rejection (with C_{adj} 25µF)



1.5A Low Dropout Positive Adjustable Regulator

Ratings and Characteristic Curves ($T_A = 25^\circ\text{C}$ unless otherwise noted)

Fig. 7 – Load Transient Response

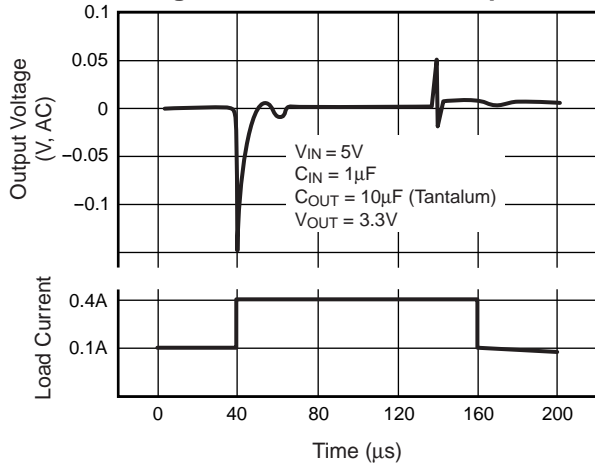
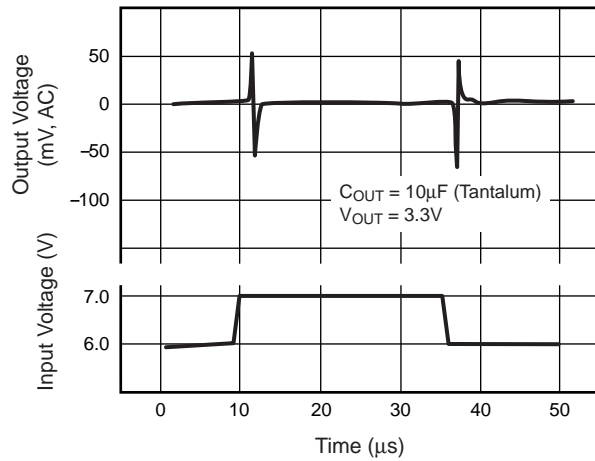

Fig. 8 – Line Transient Response



Ordering Information

GS1086Cxx xxx

↑
 Output Voltage
 Default: Adj.
 2.85: 2.85V
 3.3: 3.3V
 5: 5.0V

↑
 Package Type
 ST: SOT-223
 T: TO-220
 M: TO-263
 E: TO-252

1.5A Low Dropout Positive Adjustable Regulator

SOT-223 Case Outline

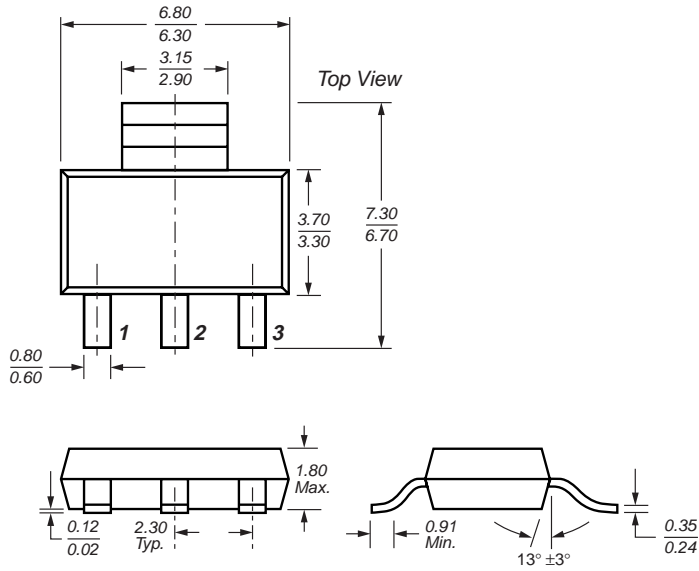

TO-252 (DPAK)

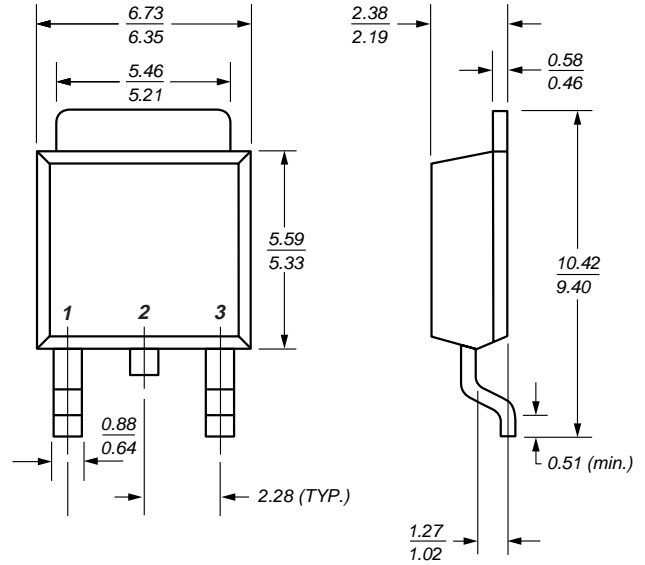

Dimensions in millimeters

TO-263 Case Outline

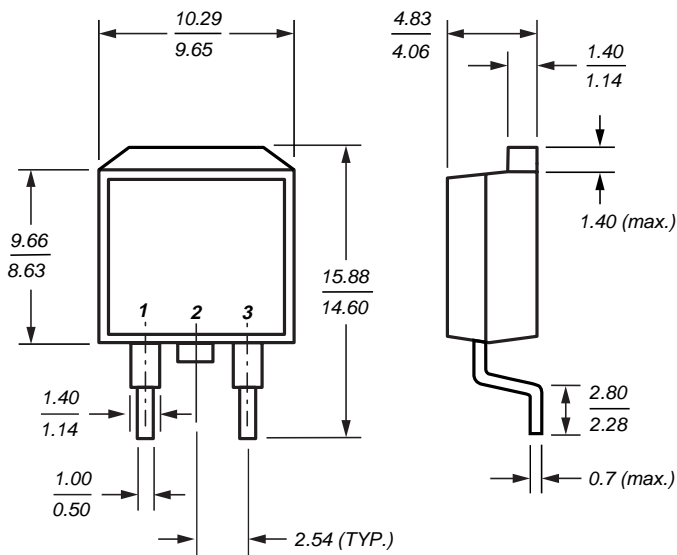

TO-220 Case Outline

