

# MOS INTEGRATED CIRCUIT

## $\mu$ PD4442161, 4442181, 4442321, 4442361

### 4M-BIT CMOS SYNCHRONOUS FAST SRAM FLOW THROUGH OPERATION

#### Description

The  $\mu$ PD4442161 is a 262,144-word by 16-bit, the  $\mu$ PD4442181 is a 262,144-word by 18-bit, the  $\mu$ PD4442321 is a 131,072-word by 32-bit and the  $\mu$ PD4442361 is a 131,072-word by 36-bit synchronous static RAM fabricated with advanced CMOS technology using Full-CMOS six-transistor memory cell.

The  $\mu$ PD4442161,  $\mu$ PD4442181,  $\mu$ PD4442321 and  $\mu$ PD4442361 integrate unique synchronous peripheral circuitry, 2-bit burst counter and output buffer as well as SRAM core. All input registers are controlled by a positive edge of the single clock input (CLK).

The  $\mu$ PD4442161,  $\mu$ PD4442181,  $\mu$ PD4442321 and  $\mu$ PD4442361 are suitable for applications which require synchronous operation, high speed, low voltage, high density and wide bit configuration, such as cache and buffer memory.

ZZ has to be set LOW at the normal operation. When ZZ is set HIGH, the SRAM enters Power Down State ("Sleep"). In the "Sleep" state, the SRAM internal state is preserved. When ZZ is set LOW again, the SRAM resumes normal operation.

The  $\mu$ PD4442161,  $\mu$ PD4442181,  $\mu$ PD4442321 and  $\mu$ PD4442361 are packaged in 100-pin PLASTIC LQFP with a 1.4 mm package thickness for high density and low capacitive loading.

#### Features

- 3.3 V (A version) or 2.5 V (C version) Core Supply
- Synchronous operation
- Internally self-timed write control
- Burst read / write : Interleaved burst and linear burst sequence
- Fully registered inputs for flow through operation
- All registers triggered off positive clock edge
- 3.3 V or 2.5 V LVTTTL Compatible : All inputs and outputs
- Fast clock access time : 6.5 ns (133 MHz), 7.5 ns (117 MHz), 8.5 ns (100 MHz)
- Asynchronous output enable : /G
- Burst sequence selectable : MODE
- Sleep mode : ZZ (ZZ = Open or Low : Normal operation)
- Separate byte write enable : /BW1 - /BW4 ( $\mu$ PD4442321,  $\mu$ PD4442361), /BW1 - /BW2 ( $\mu$ PD4442161,  $\mu$ PD4442181), /BWE
- Global write enable : /GW
- Three chip enables for easy depth expansion
- Common I/O using three state outputs

**The information in this document is subject to change without notice. Before using this document, please confirm that this is the latest version.  
Not all devices/types available in every country. Please check with local NEC representative for availability and additional information.**

★ Ordering Information

Part number	Access Time ns	Clock Frequency MHz	Core Supply Voltage V	I/O Interface	Package	Remark
μPD4442161GF-A65	6.5	133	3.3 ± 0.165	3.3 V or 2.5 V  LVTTTL	100-pin PLASTIC  LQFP (14 × 20)	A version
μPD4442161GF-A75	7.5	117				
μPD4442161GF-A85	8.5	100				
μPD4442181GF-A65	6.5	133				
μPD4442181GF-A75	7.5	117				
μPD4442181GF-A85	8.5	100				
μPD4442321GF-A65	6.5	133				
μPD4442321GF-A75	7.5	117				
μPD4442321GF-A85	8.5	100				
μPD4442361GF-A65	6.5	133				
μPD4442361GF-A75	7.5	117				
μPD4442361GF-A85	8.5	100				
μPD4442161GF-C75 <sup>Note</sup>	7.5	117				
μPD4442161GF-C85 <sup>Note</sup>	8.5	100				
μPD4442181GF-C75 <sup>Note</sup>	7.5	117				
μPD4442181GF-C85 <sup>Note</sup>	8.5	100				
μPD4442321GF-C75 <sup>Note</sup>	7.5	117				
μPD4442321GF-C85 <sup>Note</sup>	8.5	100				
μPD4442361GF-C75 <sup>Note</sup>	7.5	117				
μPD4442361GF-C85 <sup>Note</sup>	8.5	100				

**Note** Under development

Pin Configurations (Marking Side)

/xxx indicates active low signal.

100-pin PLASTIC LQFP (14 × 20)  
[ μPD4442161GF, μPD4442181GF ]

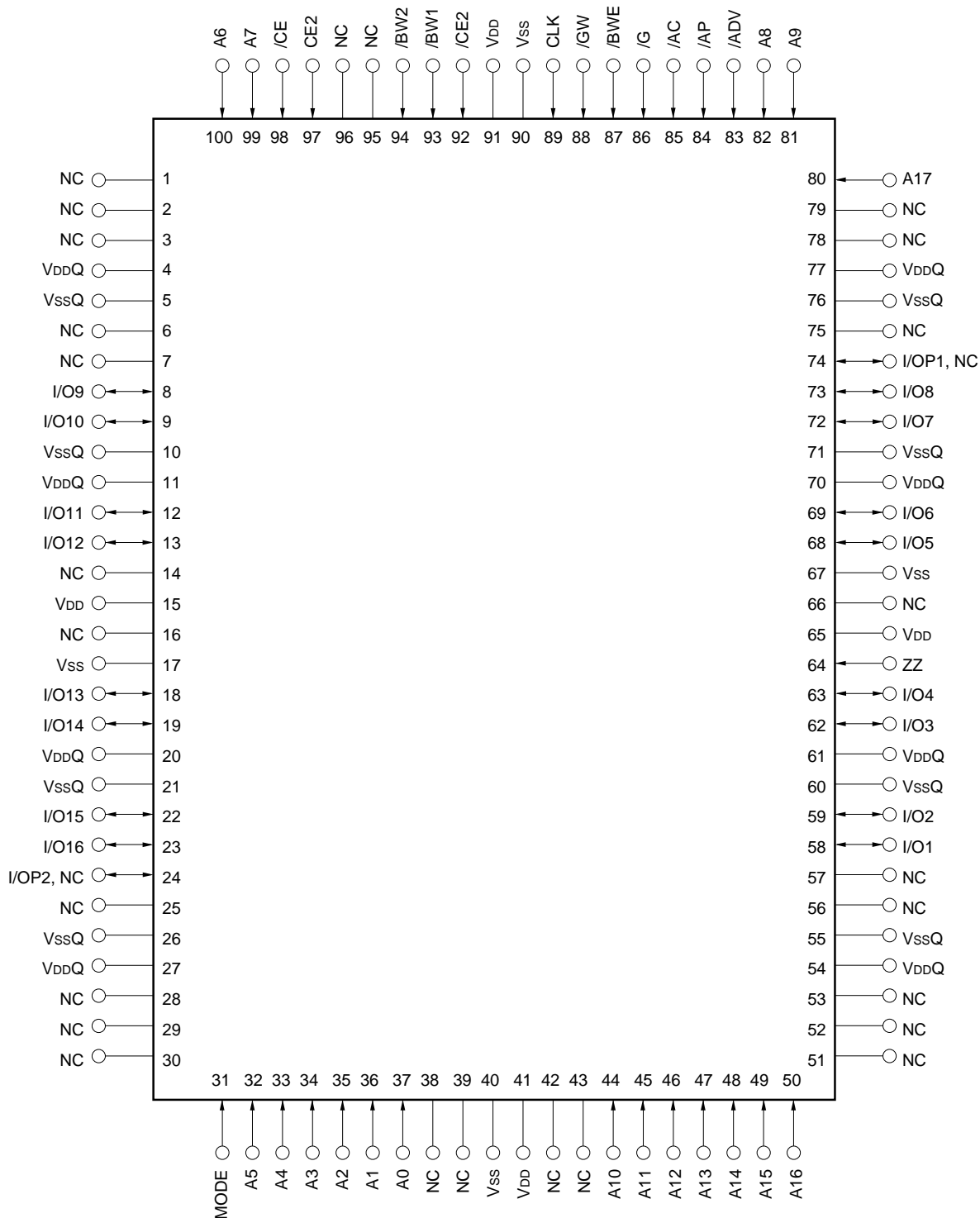

Remark Refer to Package Drawing for 1-pin index mark.

## Pin Identifications

[  $\mu$ PD4442161GF,  $\mu$ PD4442181GF ]

Symbol	Pin No.	Description
A0 - A17	37, 36, 35, 34, 33, 32, 100, 99, 82, 81, 44, 45, 46, 47, 48, 49, 50, 80	Synchronous Address Input
I/O1 - I/O16	58, 59, 62, 63, 68, 69, 72, 73, 8, 9, 12, 13, 18, 19, 22, 23	Synchronous Data In, Synchronous / Asynchronous Data Out
I/OP1, NC <sup>Note</sup>	74	Synchronous Data In (Parity), Synchronous / Asynchronous Data Out (Parity)
I/OP2, NC <sup>Note</sup>	24	
/ADV	83	Synchronous Burst Address Advance Input
/AP	84	Synchronous Address Status Processor Input
/AC	85	Synchronous Address Status Controller Input
/CE, CE2, /CE2	98, 97, 92	Synchronous Chip Enable Input
/BW1, /BW2, /BWE	93, 94, 87	Synchronous Byte Write Enable Input
/GW	88	Synchronous Global Write Input
/G	86	Asynchronous Output Enable Input
CLK	89	Clock Input
MODE	31	Asynchronous Burst Sequence Select Input Do not change state during normal operation
ZZ	64	Asynchronous Power Down State Input
VDD	15, 41, 65, 91	Power Supply
VSS	17, 40, 67, 90	Ground
VDDQ	4, 11, 20, 27, 54, 61, 70, 77	Output Buffer Power Supply
VSSQ	5, 10, 21, 26, 55, 60, 71, 76	Output Buffer Ground
NC	1, 2, 3, 6, 7, 14, 16, 25, 28, 29, 30, 38, 39, 42, 43, 51, 52, 53, 56, 57, 66, 75, 78, 79, 95, 96	No Connection

**Note** NC (No Connection) is used in the  $\mu$ PD4442161GF.

I/OP1 - I/OP2 are used in the  $\mu$ PD4442181GF.

100-pin PLASTIC LQFP (14 × 20)  
 [ μPD4442321GF, μPD4442361GF ]

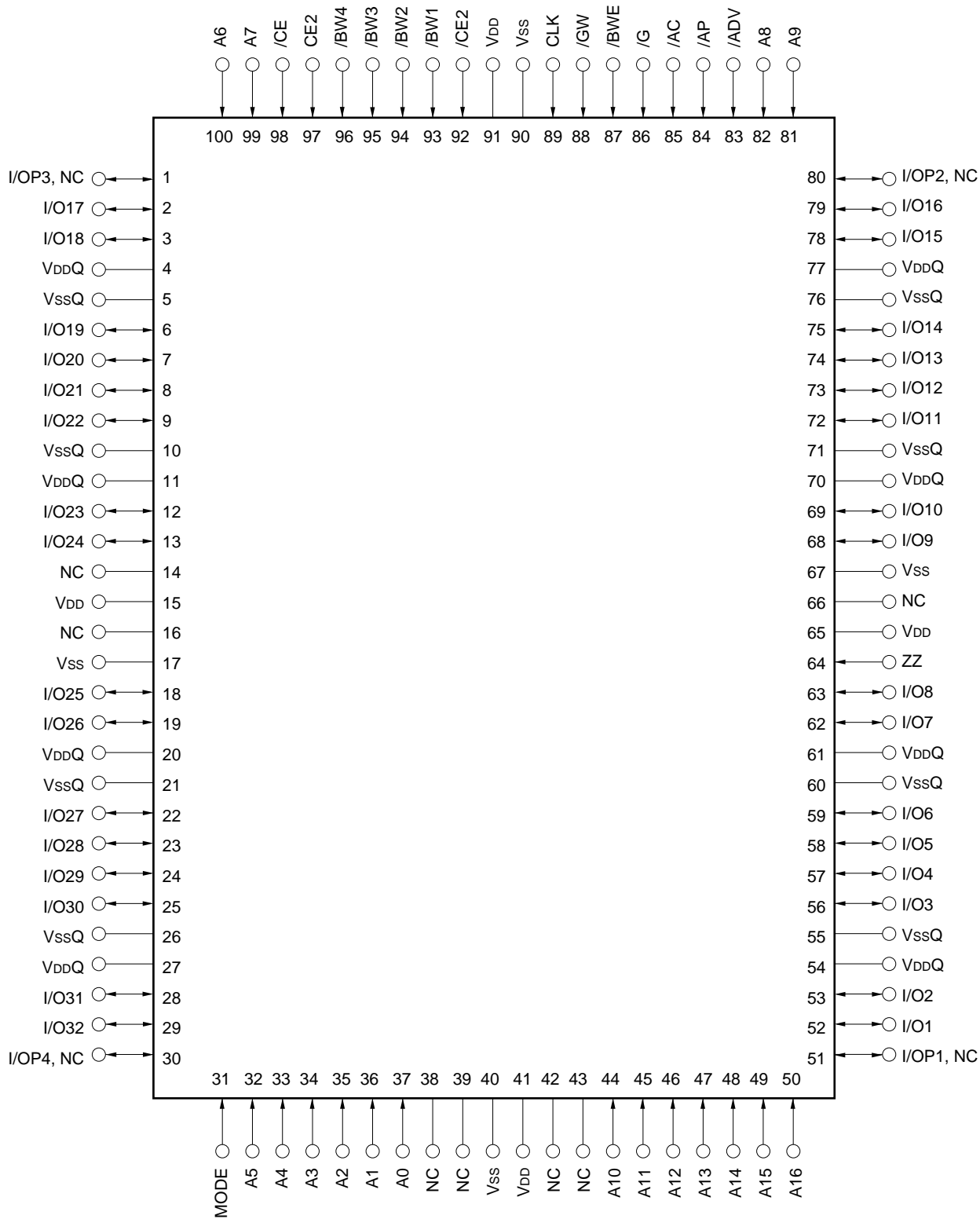

Remark Refer to Package Drawing for 1-pin index mark.

## [ μPD4442321GF, μPD4442361GF ]

Symbol	Pin No.	Description
A0 - A16	37, 36, 35, 34, 33, 32, 100, 99, 82, 81, 44, 45, 46, 47, 48, 49, 50	Synchronous Address Input
I/O1 - I/O32	52, 53, 56, 57, 58, 59, 62, 63, 68, 69, 72, 73, 74, 75, 78, 79, 2, 3, 6, 7, 8, 9, 12, 13, 18, 19, 22, 23, 24, 25, 28, 29	Synchronous Data In, Synchronous / Asynchronous Data Out
I/OP1, NC <sup>Note</sup>	51	Synchronous Data In (Parity), Synchronous / Asynchronous Data Out (Parity)
I/OP2, NC <sup>Note</sup>	80	
I/OP3, NC <sup>Note</sup>	1	
I/OP4, NC <sup>Note</sup>	30	
/ADV	83	Synchronous Burst Address Advance Input
/AP	84	Synchronous Address Status Processor Input
/AC	85	Synchronous Address Status Controller Input
/CE, CE2, /CE2	98, 97, 92	Synchronous Chip Enable Input
/BW1 - /BW4, /BWE	93, 94, 95, 96, 87	Synchronous Byte Write Enable Input
/GW	88	Synchronous Global Write Input
/G	86	Asynchronous Output Enable Input
CLK	89	Clock Input
MODE	31	Asynchronous Burst Sequence Select Input Do not change state during normal operation
ZZ	64	Asynchronous Power Down State Input
VDD	15, 41, 65, 91	Power Supply
VSS	17, 40, 67, 90	Ground
VDDQ	4, 11, 20, 27, 54, 61, 70, 77	Output Buffer Power Supply
VSSQ	5, 10, 21, 26, 55, 60, 71, 76	Output Buffer Ground
NC	14, 16, 38, 39, 42, 43, 66	No Connection

**Note** NC (No Connection) is used in the μPD4442321GF.

I/OP1 - I/OP4 are used in the μPD4442361GF.

Block Diagrams

[ μPD4442161, μPD4442181 ]

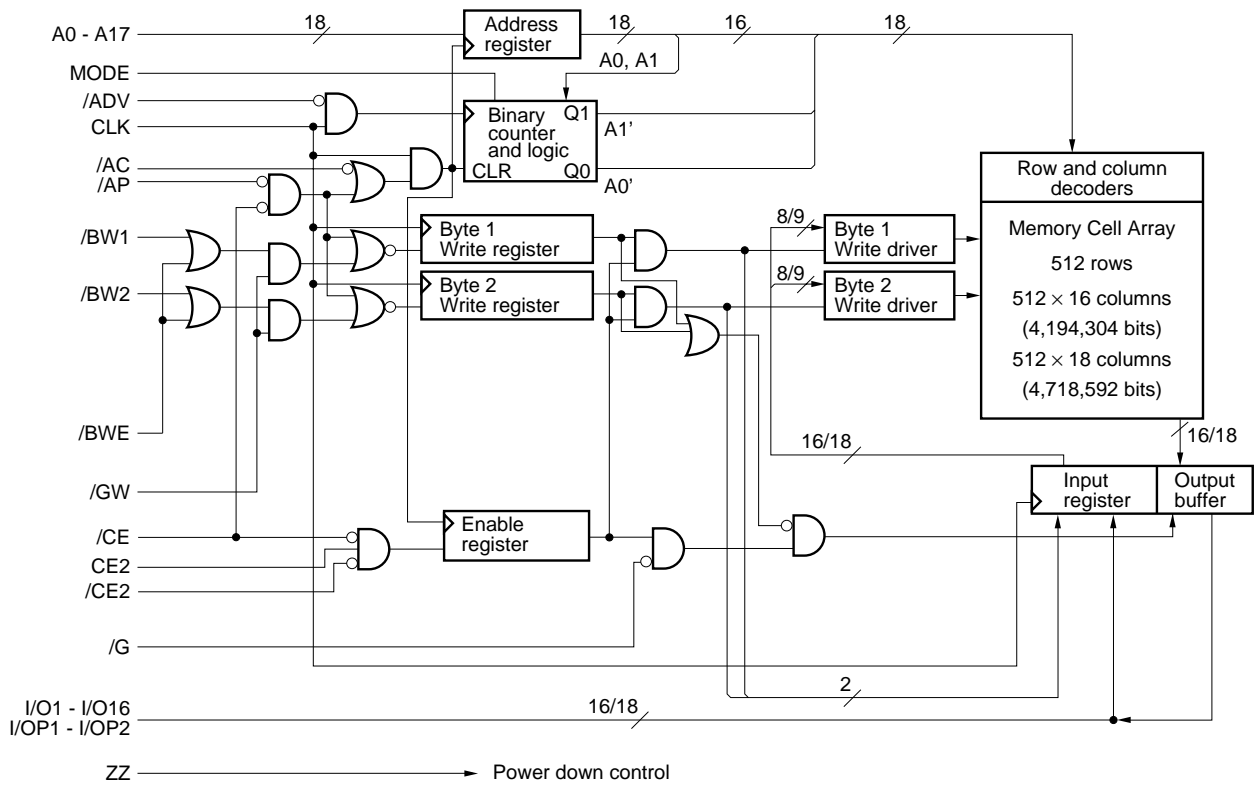

Burst Sequence

[ μPD4442161, μPD4442181 ]

Interleaved Burst Sequence Table (MODE = Open or VDD)

External Address	A17 - A2, A1, A0
1st Burst Address	A17 - A2, A1, /A0
2nd Burst Address	A17 - A2, /A1, A0
3rd Burst Address	A17 - A2, /A1, /A0

Linear Burst Sequence Table (MODE = Vss)

External Address	A17 - A2, 0, 0	A17 - A2, 0, 1	A17 - A2, 1, 0	A17 - A2, 1, 1
1st Burst Address	A17 - A2, 0, 1	A17 - A2, 1, 0	A17 - A2, 1, 1	A17 - A2, 0, 0
2nd Burst Address	A17 - A2, 1, 0	A17 - A2, 1, 1	A17 - A2, 0, 0	A17 - A2, 0, 1
3rd Burst Address	A17 - A2, 1, 1	A17 - A2, 0, 0	A17 - A2, 0, 1	A17 - A2, 1, 0

[ μPD4442321, μPD4442361 ]

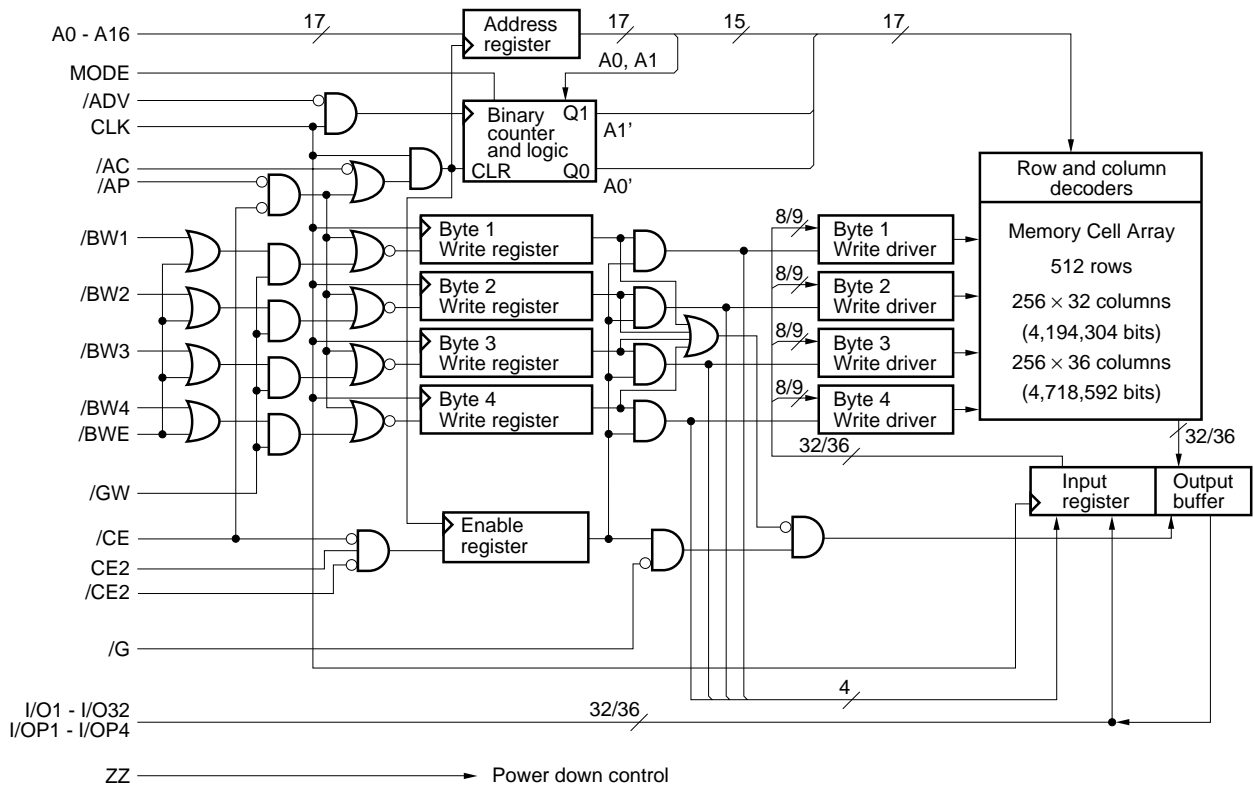

[ μPD4442321, μPD4442361 ]

**Interleaved Burst Sequence Table (MODE = Open or VDD)**

External Address	A16 - A2, A1, A0
1st Burst Address	A16 - A2, A1, /A0
2nd Burst Address	A16 - A2, /A1, A0
3rd Burst Address	A16 - A2, /A1, /A0

**Linear Burst Sequence Table (MODE = Vss)**

External Address	A16 - A2, 0, 0	A16 - A2, 0, 1	A16 - A2, 1, 0	A16 - A2, 1, 1
1st Burst Address	A16 - A2, 0, 1	A16 - A2, 1, 0	A16 - A2, 1, 1	A16 - A2, 0, 0
2nd Burst Address	A16 - A2, 1, 0	A16 - A2, 1, 1	A16 - A2, 0, 0	A16 - A2, 0, 1
3rd Burst Address	A16 - A2, 1, 1	A16 - A2, 0, 0	A16 - A2, 0, 1	A16 - A2, 1, 0



**Asynchronous Truth Table**

Operation	/G	I/O
Read Cycle	L	Dout
Read Cycle	H	Hi-Z
Write Cycle	×	Hi-Z, Din
Deselected	×	Hi-Z

**Remark** × : don't care

**Synchronous Truth Table**

Operation	/CE	CE2	/CE2	/AP	/AC	/ADV	/WRITE	CLK	Address
Deselected <sup>Note</sup>	H	×	×	×	L	×	×	L → H	None
Deselected <sup>Note</sup>	L	L	×	L	×	×	×	L → H	None
Deselected <sup>Note</sup>	L	×	H	L	×	×	×	L → H	None
Deselected <sup>Note</sup>	L	L	×	H	L	×	×	L → H	None
Deselected <sup>Note</sup>	L	×	H	H	L	×	×	L → H	None
Read Cycle / Begin Burst	L	H	L	L	×	×	×	L → H	External
Read Cycle / Begin Burst	L	H	L	H	L	×	H	L → H	External
Read Cycle / Continue Burst	×	×	×	H	H	L	H	L → H	Next
Read Cycle / Continue Burst	H	×	×	×	H	L	H	L → H	Next
Read Cycle / Suspend Burst	×	×	×	H	H	H	H	L → H	Current
Read Cycle / Suspend Burst	H	×	×	×	H	H	H	L → H	Current
Write Cycle / Begin Burst	L	H	L	H	L	×	L	L → H	External
Write Cycle / Continue Burst	×	×	×	H	H	L	L	L → H	Next
Write Cycle / Continue Burst	H	×	×	×	H	L	L	L → H	Next
Write Cycle / Suspend Burst	×	×	×	H	H	H	L	L → H	Current
Write Cycle / Suspend Burst	H	×	×	×	H	H	L	L → H	Current

**Note** Deselect status is held until new "Begin Burst" entry.

**Remarks 1.** × : don't care

2. /WRITE = L means any one or more byte write enables (/BW1, /BW2, /BW3 or /BW4) and /BWE are LOW or /GW is LOW.

/WRITE = H means the following two cases.

(1) /BWE and /GW are HIGH.

(2) /BW1, /BW2, /BW3, /BW4 and /GW are HIGH, and /BWE is LOW.

Partial Truth Table for Write Enables

[ μPD4442161, μPD4442181 ]

Operation	/GW	/BWE	/BW1	/BW2
Read Cycle	H	H	×	×
Read Cycle	H	L	H	H
Write Cycle / Byte 1 Only	H	L	L	H
Write Cycle / All Bytes	H	L	L	L
Write Cycle / All Bytes	L	×	×	×

Remark × : don't care

[ μPD4442321, μPD4442361 ]

Operation	/GW	/BWE	/BW1	/BW2	/BW3	/BW4
Read Cycle	H	H	×	×	×	×
Read Cycle	H	L	H	H	H	H
Write Cycle / Byte 1 Only	H	L	L	H	H	H
Write Cycle / All Bytes	H	L	L	L	L	L
Write Cycle / All Bytes	L	×	×	×	×	×

Remark × : don't care

ZZ (Sleep) Truth Table

ZZ	Chip Status
≤ 0.2 V	Active
Open	Active
≥ V <sub>DD</sub> - 0.2 V	Sleep

**Electrical Specifications**

**Absolute Maximum Ratings**

Parameter	Symbol	Conditions	MIN.	TYP.	MAX.	Unit	Note
★ Supply voltage (A version)	V <sub>DD</sub>		-0.5		+4.0	V	
Supply voltage (C version)	V <sub>DD</sub>		-0.5		+3.0	V	
Output supply voltage	V <sub>DDQ</sub>		-0.5		V <sub>DD</sub>	V	
Input voltage	V <sub>IN</sub>		-0.5		V <sub>DD</sub> + 0.5	V	1, 2
Input / Output voltage	V <sub>I/O</sub>		-0.5		V <sub>DDQ</sub> + 0.5	V	1, 2
Operating ambient temperature	T <sub>A</sub>		0		70	°C	
Storage temperature	T <sub>stg</sub>		-55		+125	°C	

- Notes**
1. -2.0 V (MIN.)(Pulse width : 2 ns)
  2. V<sub>DDQ</sub> + 2.3 V (MAX.)(Pulse width : 2 ns)

**Caution** Exposing the device to stress above those listed in Absolute Maximum Ratings could cause permanent damage. The device is not meant to be operated under conditions outside the limits described in the operational section of this specification. Exposure to Absolute Maximum Rating conditions for extended periods may affect device reliability.

**Recommended DC Operating Conditions (T<sub>A</sub> = 0 to 70 °C)**

**(A version)**

Parameter	Symbol	Conditions	MIN.	TYP.	MAX.	Unit
Supply voltage	V <sub>DD</sub>		3.135	3.3	3.465	V
<b>2.5 V LVTTTL interface</b>						
Output supply voltage	V <sub>DDQ</sub>		2.375	2.5	2.9	V
High level input voltage	V <sub>IH</sub>		1.7		V <sub>DDQ</sub> + 0.3	V
Low level input voltage	V <sub>IL</sub>		-0.3 <small>Note</small>		+0.7	V
<b>3.3 V LVTTTL interface</b>						
Output supply voltage	V <sub>DDQ</sub>		3.135	3.3	3.465	V
High level input voltage	V <sub>IH</sub>		2.0		V <sub>DDQ</sub> + 0.3	V
Low level input voltage	V <sub>IL</sub>		-0.3 <small>Note</small>		+0.8	V

**Note** -0.8 V (MIN.)(Pulse width : 2 ns)

**(C version)**

Parameter	Symbol	Conditions	MIN.	TYP.	MAX.	Unit
Supply voltage	V <sub>DD</sub>		2.375	2.5	2.625	V
Output supply voltage	V <sub>DDQ</sub>		2.375	2.5	2.625	V
High level input voltage	V <sub>IH</sub>		1.7		V <sub>DDQ</sub> + 0.3	V
Low level input voltage	V <sub>IL</sub>		-0.3 <small>Note</small>		+0.7	V

**Note** -0.8 V (MIN.)(Pulse width : 2 ns)

**DC Characteristics (Recommended Operating Conditions Unless Otherwise Noted)**

Parameter	Symbol	Test condition	MIN.	TYP.	MAX.	Unit	Note
Input leakage current	I <sub>LI</sub>	V <sub>IN</sub> (except ZZ, MODE) = 0 V to V <sub>DD</sub>	-2		+2	μA	
I/O leakage current	I <sub>LO</sub>	V <sub>I/O</sub> = 0 V to V <sub>DDQ</sub> , Outputs are disabled.	-2		+2	μA	
★ Operating supply current	I <sub>DD</sub>	Device selected, Cycle = MAX.	-A65		330	mA	
		V <sub>IN</sub> ≤ V <sub>IL</sub> or V <sub>IN</sub> ≥ V <sub>IH</sub> ,	-A75, -C75		300		
		I <sub>I/O</sub> = 0 mA	-A85, -C85		280		
	I <sub>DD1</sub>	Suspend cycle, Cycle = MAX. /AC, /AP, /ADV, /GW, /BWEs ≥ V <sub>IH</sub> , V <sub>IN</sub> ≤ V <sub>IL</sub> or V <sub>IN</sub> ≥ V <sub>IH</sub> , I <sub>I/O</sub> = 0 mA			150		
Standby supply current	I <sub>SB</sub>	Device deselected, Cycle = 0 MHz, V <sub>IN</sub> ≤ V <sub>IL</sub> or V <sub>IN</sub> ≥ V <sub>IH</sub> , All inputs are static.			30	mA	
	I <sub>SB1</sub>	Device deselected, Cycle = 0 MHz, V <sub>IN</sub> ≤ 0.2 V or V <sub>IN</sub> ≥ V <sub>DD</sub> - 0.2 V, V <sub>I/O</sub> ≤ 0.2 V, All inputs are static.			10		
	I <sub>SB2</sub>	Device deselected, Cycle = MAX. V <sub>IN</sub> ≤ V <sub>IL</sub> or V <sub>IN</sub> ≥ V <sub>IH</sub>			150		
Power down supply current	I <sub>SBZZ</sub>	ZZ ≥ V <sub>DD</sub> - 0.2 V, V <sub>I/O</sub> ≤ V <sub>DDQ</sub> + 0.2 V			10	mA	
<b>2.5 V LVTTTL interface</b>							
High level output voltage	V <sub>OH</sub>	I <sub>OH</sub> = -2.0 mA	1.7			V	
		I <sub>OH</sub> = -1.0 mA	2.1				
Low level output voltage	V <sub>OL</sub>	I <sub>OL</sub> = +2.0 mA			0.7	V	
		I <sub>OL</sub> = +1.0 mA			0.4		
<b>3.3 V LVTTTL interface</b>							
High level output voltage	V <sub>OH</sub>	I <sub>OH</sub> = -4.0 mA	2.4			V	
Low level output voltage	V <sub>OL</sub>	I <sub>OL</sub> = +8.0 mA			0.4	V	

**Remark** These DC characteristics are in common regardless product classification.

**Capacitance (T<sub>A</sub> = 25 °C, f = 1MHz)**

Parameter	Symbol	Test condition	MIN.	TYP.	MAX.	Unit
★ Input capacitance	C <sub>IN</sub>	V <sub>IN</sub> = 0 V			4.5	pF
Input / Output capacitance	C <sub>I/O</sub>	V <sub>I/O</sub> = 0 V			7.0	pF
Clock input capacitance	C <sub>clk</sub>	V <sub>clk</sub> = 0 V			6.0	pF

**Remark** These parameters are not 100% tested.

AC Characteristics (Recommended Operating Conditions Unless Otherwise Noted)

AC Test Conditions

★ 2.5 V LVTTTL Interface

Input waveform (Rise / Fall time ≤ 2.4 ns)

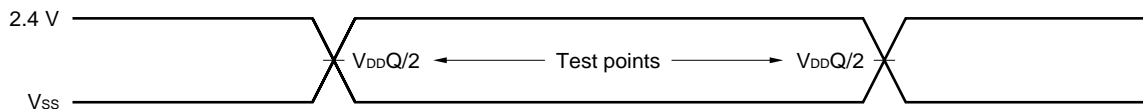

Output waveform

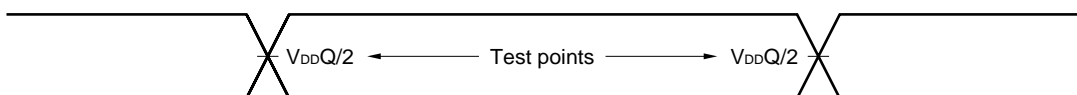

3.3 V LVTTTL Interface

Input waveform (Rise / Fall time ≤ 3.0 ns)

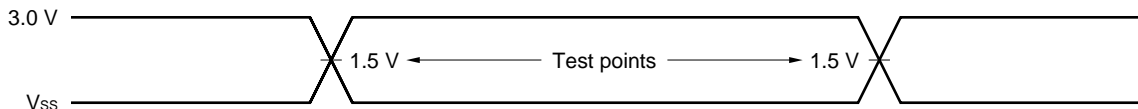

Output waveform

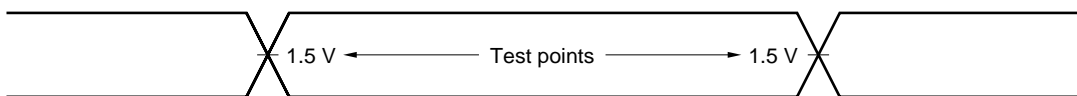

Output load condition

CL : 30 pF  
 5 pF (TKHQX1, TKHQX2, TGLQX, TGHQZ, TKHQZ)

Figure1 External load at test

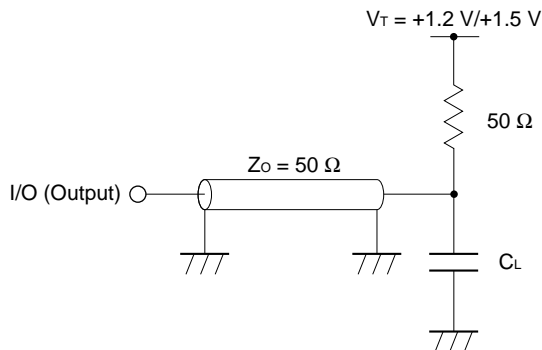

Remark CL includes capacitances of the probe and jig, and stray capacitances.

★ Read and Write Cycle

Parameter	Symbol		-A65 (133 MHz)		-A75, -C75 (117 MHz)		-A85, -C85 (100MHz)		Unit	Note
	Standard	Alias	MIN.	MAX.	MIN.	MAX.	MIN.	MAX.		
Cycle time	TKHKH	TCYC	7.5	–	8.6	–	10.0	–	ns	
Clock access time	TKHQV	TCD	–	6.5	–	7.5	–	8.5	ns	
Output enable access time	TGLQV	TOE	–	3.5	–	3.5	–	3.5	ns	
Clock high to output active	TKHQX1	TDC1	2.5	–	2.5	–	2.5	–	ns	
Clock high to output change	TKHQX2	TDC2	2.5	–	2.5	–	2.5	–	ns	
Output enable to output active	TGLQX	TOLZ	0	–	0	–	0	–	ns	
Output disable to output high-Z	TGHQZ	TOHZ	0	3.5	0	3.5	0	3.5	ns	
Clock high to output high-Z	TKHQZ	TCZ	2.5	4.0	2.5	4.0	2.5	4.0	ns	
Clock high pulse width	TKHKL	TCH	2.5	–	2.5	–	2.5	–	ns	
Clock low pulse width	TKLKH	TCL	2.5	–	2.5	–	2.5	–	ns	
Setup times	Address	TAVKH	TAS	1.5	–	1.5	–	2.0	–	ns
	Address status	TADSVKH	TSS							
	Data in	TDVKH	TDS							
	Write enable	TWVKH	TWS							
	Address advance	TADVVKH	–							
	Chip enable	TEVKH	–							
Hold times	Address	TKHAX	TAH	0.5	–	0.5	–	0.5	–	ns
	Address status	TKHADSX	TSH							
	Data in	TKHDX	TDH							
	Write enable	TKHWX	TWH							
	Address advance	TKHADVX	–							
	Chip enable	TKHEX	–							
Power down entry time	TZZE	TZZE	–	7.5	–	8.6	–	10.0	ns	
Power down recovery time	TZZR	TZZR	–	7.5	–	8.6	–	10.0	ns	

**READ CYCLE**

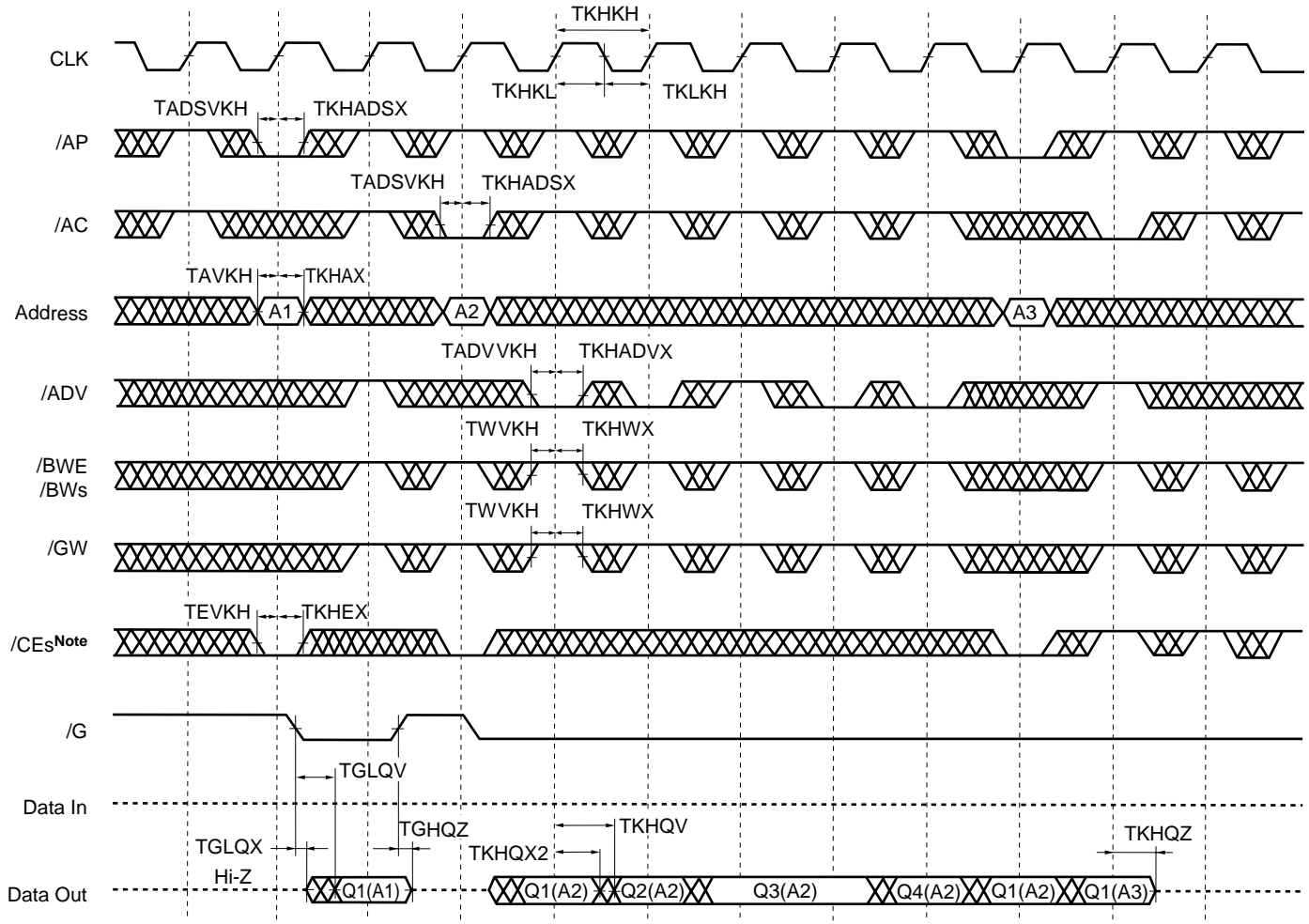

**Note** /CEs refers to /CE, CE2 and /CE2. When /CEs is LOW, /CE and /CE2 are LOW and CE2 is HIGH. When /CEs is HIGH, /CE and /CE2 are HIGH and CE2 is LOW.

**Remark** Qn(A2) refers to output from address A2. Q1-Q4 refer to outputs according to burst sequence.

**WRITE CYCLE**

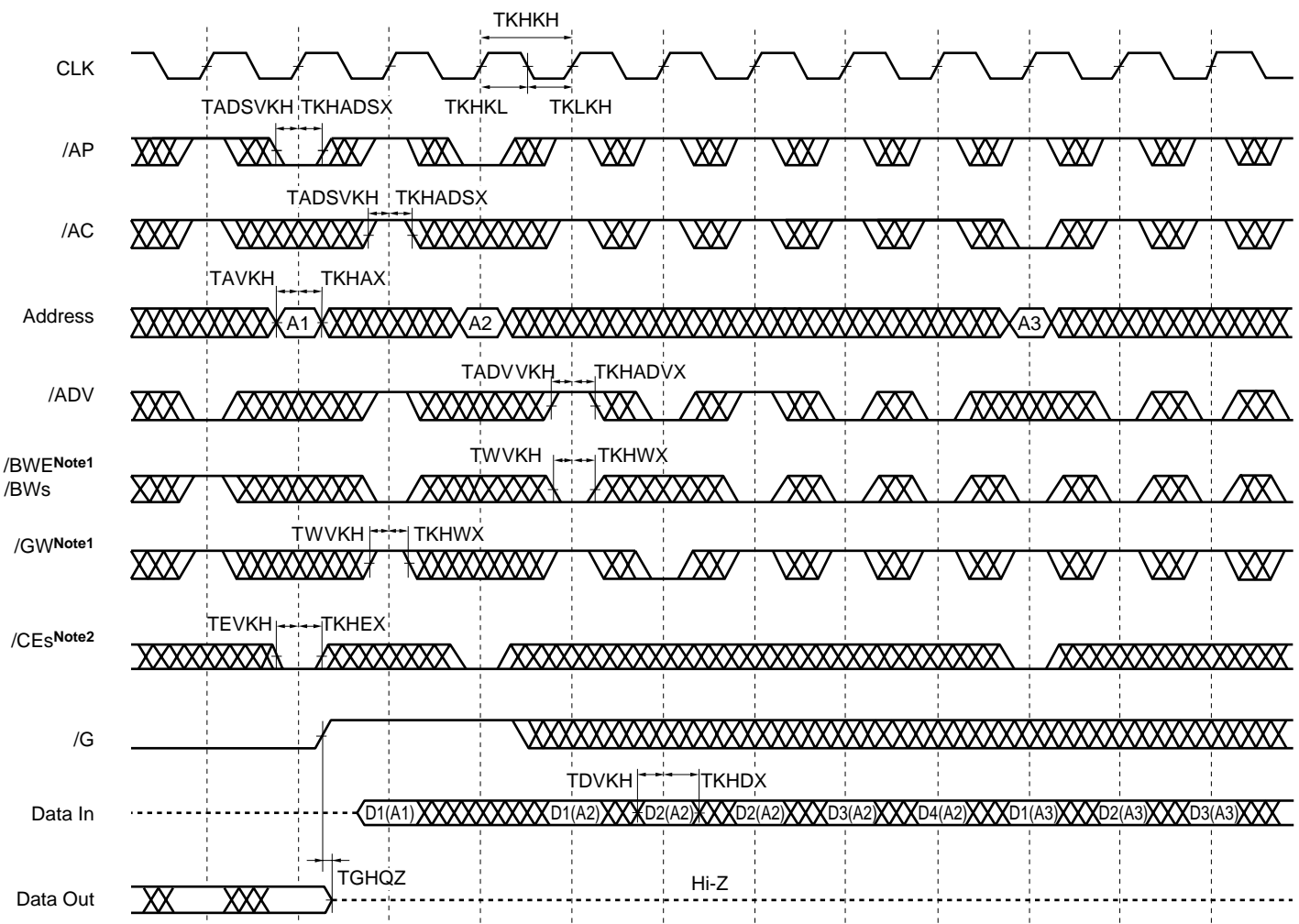

- Notes**
1. All bytes WRITE can be initiated by /GW LOW or /GW HIGH and /BWE, /BW1-/BW4 LOW.
  2. /CEs refers to /CE, CE2 and /CE2. When /CEs is LOW, /CE and /CE2 are LOW and CE2 is HIGH. When /CEs is HIGH, /CE and /CE2 are HIGH and CE2 is LOW.



READ / WRITE CYCLE

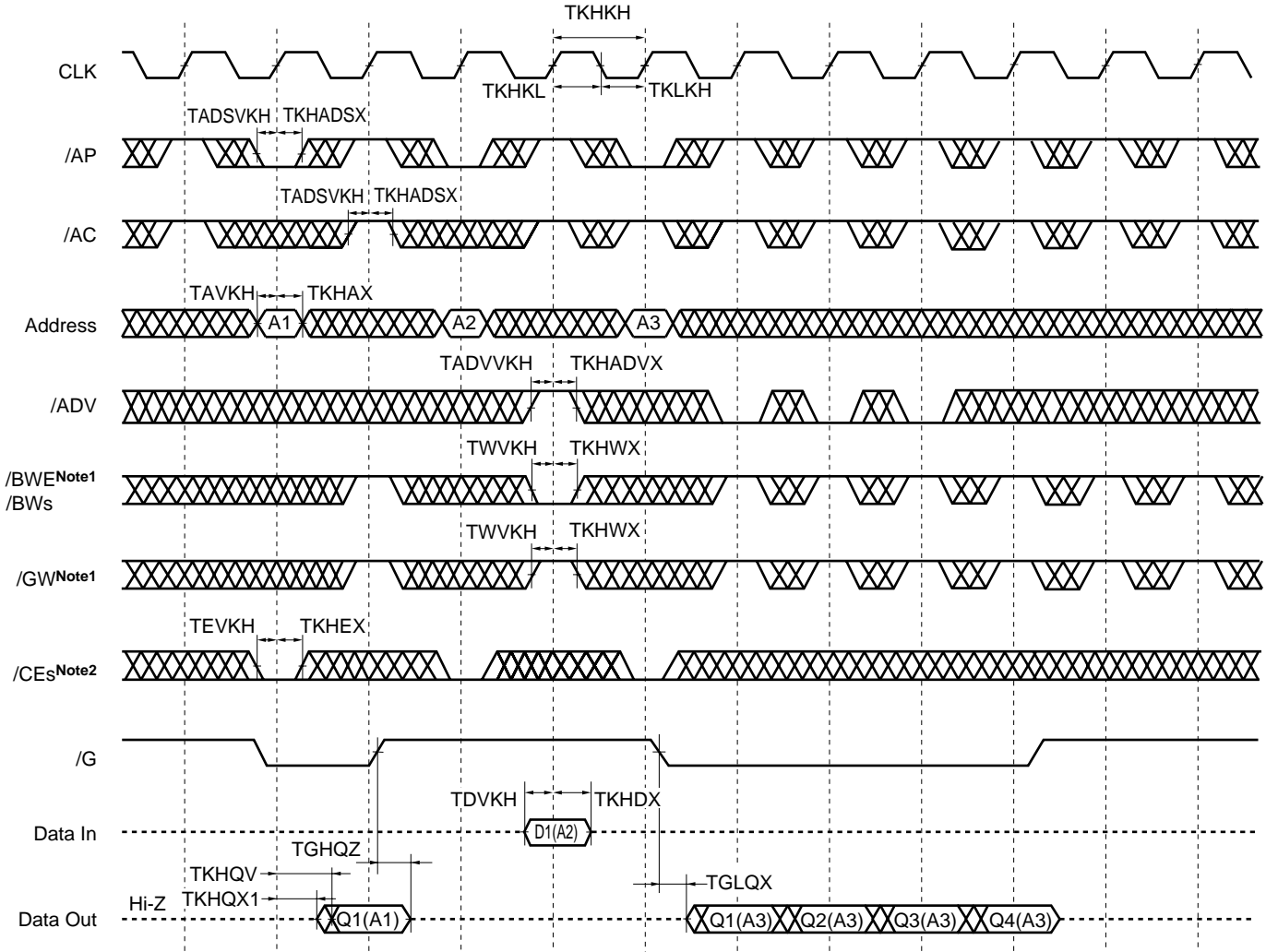

- Notes**
1. All bytes WRITE can be initiated by /GW LOW or /GW HIGH and /BWE, /BW1-/BW4 LOW.
  2. /CEs refers to /CE, CE2 and /CE2. When /CEs is LOW, /CE and /CE2 are LOW and CE2 is HIGH. When /CEs is HIGH, /CE and /CE2 are HIGH and CE2 is LOW.

**POWER DOWN (ZZ) CYCLE**

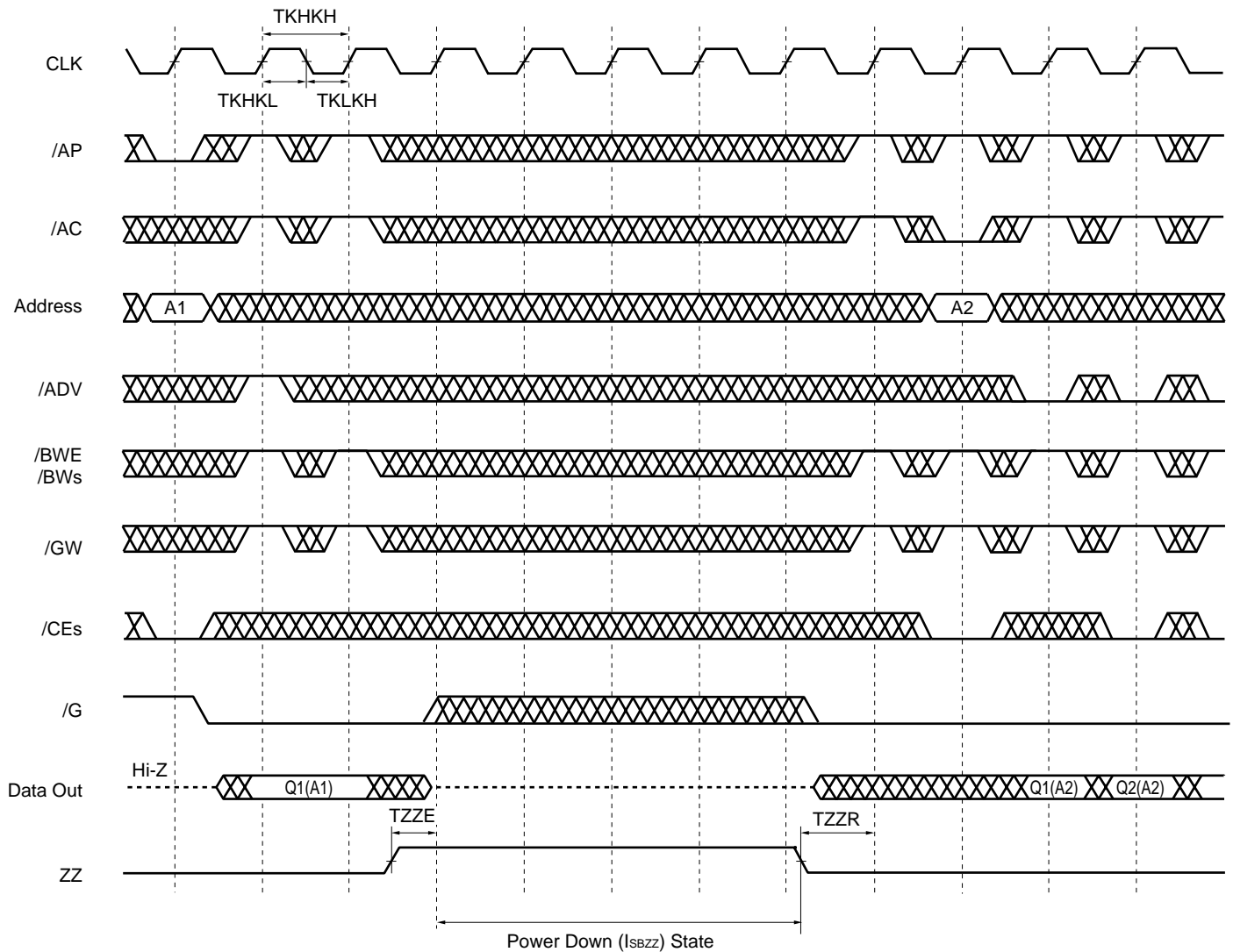

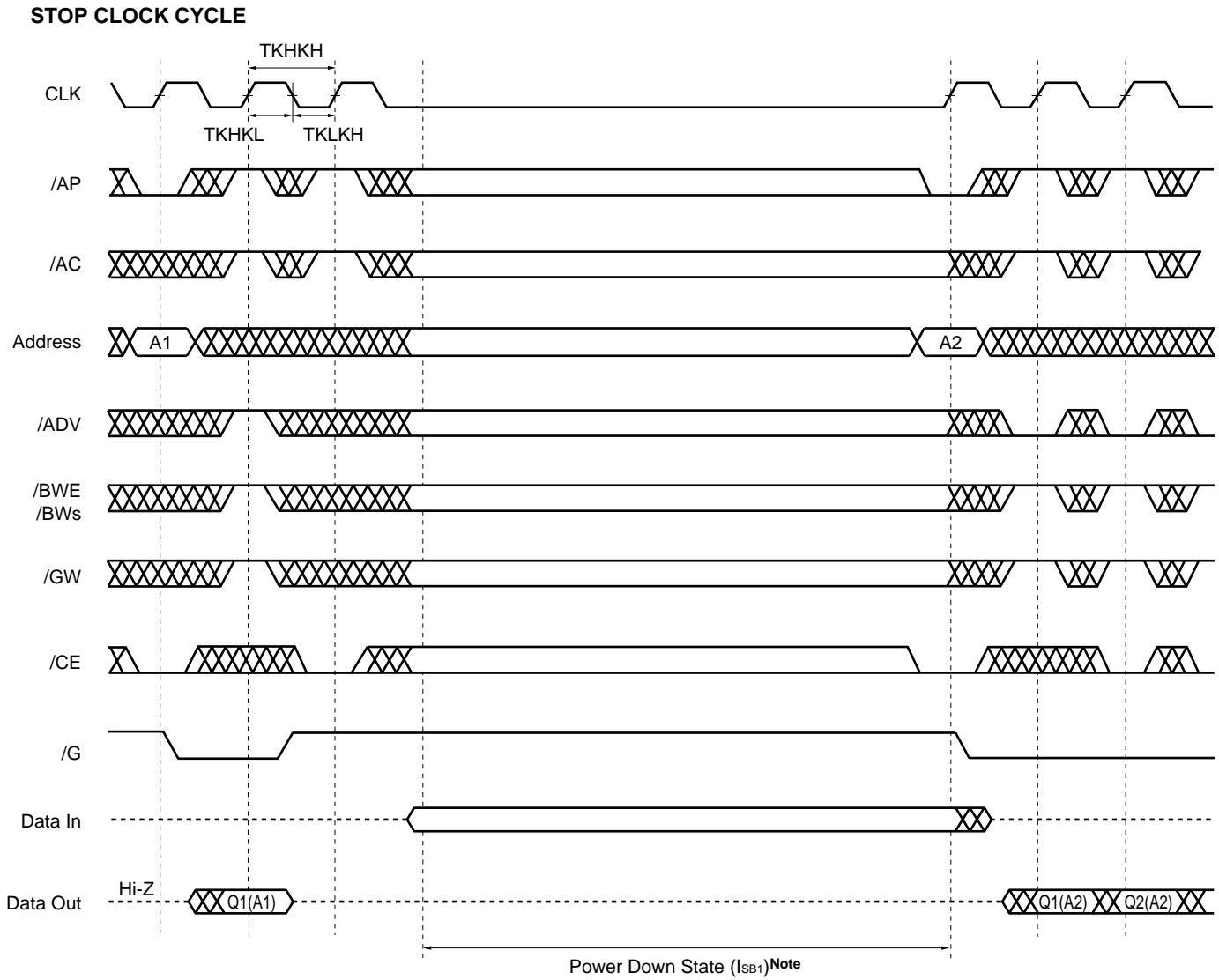

**Note**  $V_{IN} \leq 0.2 V$  or  $V_{IN} \geq V_{DD} - 0.2 V$ ,  $V_{IO} \leq 0.2 V$

Package Drawing

100-PIN PLASTIC LQFP (14x20)

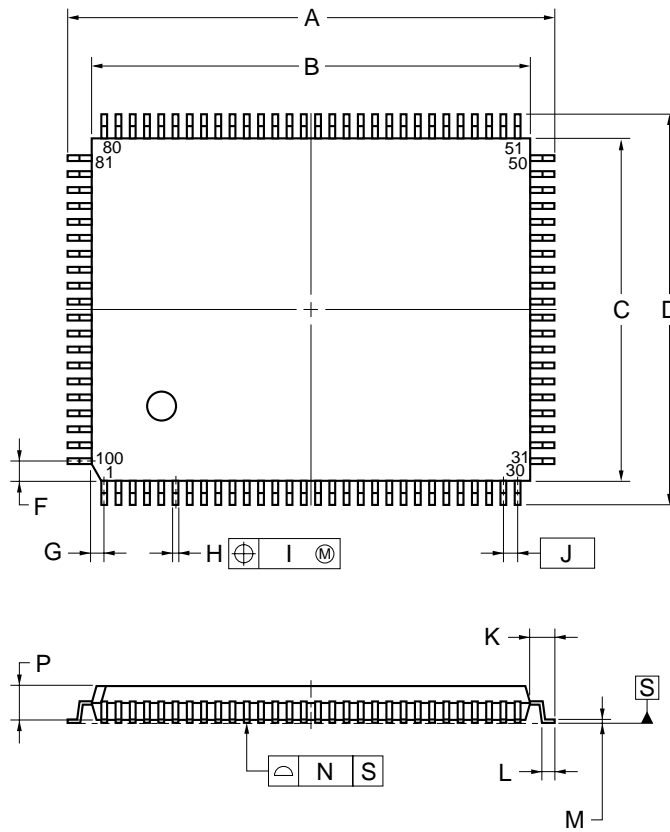

NOTE

Each lead centerline is located within 0.13 mm of its true position (T.P.) at maximum material condition.

ITEM	MILLIMETERS
A	22.0±0.2
B	20.0±0.2
C	14.0±0.2
D	16.0±0.2
F	0.825
G	0.575
H	0.32 <sup>+0.08</sup> <sub>-0.07</sub>
I	0.13
J	0.65 (T.P.)
K	1.0±0.2
L	0.5±0.2
M	0.17 <sup>+0.06</sup> <sub>-0.05</sub>
N	0.10
P	1.4
Q	0.125±0.075
R	3° <sup>+7°</sup> <sub>-3°</sub>
S	1.7 MAX.

S100GF-65-8ET-1

**Recommended Soldering Condition**

Please consult with our sales offices for soldering conditions of the  $\mu$ PD4442161, 4442181, 4442321 and 4442361.

**Types of Surface Mount Devices**

$\mu$ PD4442161GF : 100-pin PLASTIC LQFP (14 × 20)

$\mu$ PD4442181GF : 100-pin PLASTIC LQFP (14 × 20)

$\mu$ PD4442321GF : 100-pin PLASTIC LQFP (14 × 20)

$\mu$ PD4442361GF : 100-pin PLASTIC LQFP (14 × 20)

[ MEMO ]

## NOTES FOR CMOS DEVICES

**① PRECAUTION AGAINST ESD FOR SEMICONDUCTORS**

Note:

Strong electric field, when exposed to a MOS device, can cause destruction of the gate oxide and ultimately degrade the device operation. Steps must be taken to stop generation of static electricity as much as possible, and quickly dissipate it once, when it has occurred. Environmental control must be adequate. When it is dry, humidifier should be used. It is recommended to avoid using insulators that easily build static electricity. Semiconductor devices must be stored and transported in an anti-static container, static shielding bag or conductive material. All test and measurement tools including work bench and floor should be grounded. The operator should be grounded using wrist strap. Semiconductor devices must not be touched with bare hands. Similar precautions need to be taken for PW boards with semiconductor devices on it.

**② HANDLING OF UNUSED INPUT PINS FOR CMOS**

Note:

No connection for CMOS device inputs can be cause of malfunction. If no connection is provided to the input pins, it is possible that an internal input level may be generated due to noise, etc., hence causing malfunction. CMOS devices behave differently than Bipolar or NMOS devices. Input levels of CMOS devices must be fixed high or low by using a pull-up or pull-down circuitry. Each unused pin should be connected to  $V_{DD}$  or GND with a resistor, if it is considered to have a possibility of being an output pin. All handling related to the unused pins must be judged device by device and related specifications governing the devices.

**③ STATUS BEFORE INITIALIZATION OF MOS DEVICES**

Note:

Power-on does not necessarily define initial status of MOS device. Production process of MOS does not define the initial operation status of the device. Immediately after the power source is turned ON, the devices with reset function have not yet been initialized. Hence, power-on does not guarantee out-pin levels, I/O settings or contents of registers. Device is not initialized until the reset signal is received. Reset operation must be executed immediately after power-on for devices having reset function.

- **The information in this document is current as of May, 2001. The information is subject to change without notice. For actual design-in, refer to the latest publications of NEC's data sheets or data books, etc., for the most up-to-date specifications of NEC semiconductor products. Not all products and/or types are available in every country. Please check with an NEC sales representative for availability and additional information.**
  - No part of this document may be copied or reproduced in any form or by any means without prior written consent of NEC. NEC assumes no responsibility for any errors that may appear in this document.
  - NEC does not assume any liability for infringement of patents, copyrights or other intellectual property rights of third parties by or arising from the use of NEC semiconductor products listed in this document or any other liability arising from the use of such products. No license, express, implied or otherwise, is granted under any patents, copyrights or other intellectual property rights of NEC or others.
  - Descriptions of circuits, software and other related information in this document are provided for illustrative purposes in semiconductor product operation and application examples. The incorporation of these circuits, software and information in the design of customer's equipment shall be done under the full responsibility of customer. NEC assumes no responsibility for any losses incurred by customers or third parties arising from the use of these circuits, software and information.
  - While NEC endeavours to enhance the quality, reliability and safety of NEC semiconductor products, customers agree and acknowledge that the possibility of defects thereof cannot be eliminated entirely. To minimize risks of damage to property or injury (including death) to persons arising from defects in NEC semiconductor products, customers must incorporate sufficient safety measures in their design, such as redundancy, fire-containment, and anti-failure features.
  - NEC semiconductor products are classified into the following three quality grades:  
"Standard", "Special" and "Specific". The "Specific" quality grade applies only to semiconductor products developed based on a customer-designated "quality assurance program" for a specific application. The recommended applications of a semiconductor product depend on its quality grade, as indicated below. Customers must check the quality grade of each semiconductor product before using it in a particular application.
    - "Standard": Computers, office equipment, communications equipment, test and measurement equipment, audio and visual equipment, home electronic appliances, machine tools, personal electronic equipment and industrial robots
    - "Special": Transportation equipment (automobiles, trains, ships, etc.), traffic control systems, anti-disaster systems, anti-crime systems, safety equipment and medical equipment (not specifically designed for life support)
    - "Specific": Aircraft, aerospace equipment, submersible repeaters, nuclear reactor control systems, life support systems and medical equipment for life support, etc.
- The quality grade of NEC semiconductor products is "Standard" unless otherwise expressly specified in NEC's data sheets or data books, etc. If customers wish to use NEC semiconductor products in applications not intended by NEC, they must contact an NEC sales representative in advance to determine NEC's willingness to support a given application.
- (Note)
- (1) "NEC" as used in this statement means NEC Corporation and also includes its majority-owned subsidiaries.
  - (2) "NEC semiconductor products" means any semiconductor product developed or manufactured by or for NEC (as defined above).