

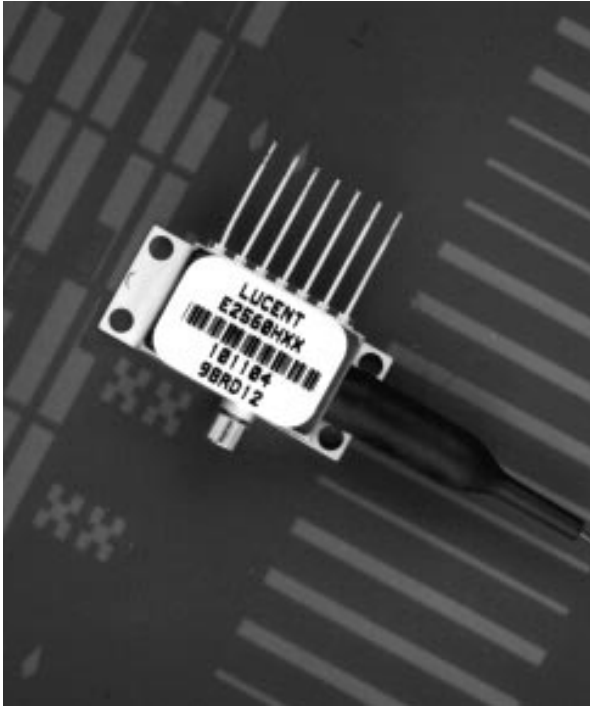

## E2560/E2580-Type 10 Gbits/s EML Modules



### Features

- Integrated electroabsorptive modulator
- 1.5  $\mu\text{m}$  wavelength
- Characterized for 10 Gbits/s operation
- For use up to 80 km at 10 Gbits/s
- Low modulation voltage
- Temperature stabilized
- Available with and without integral driver IC
- Wavelength selectable to ITU-T standards
- Ultrastable wavelength aging for DWDM

### Applications

- SONET/SDH applications
- Ultrahigh capacity WDM system application
- High-speed data communication
- Digitized video

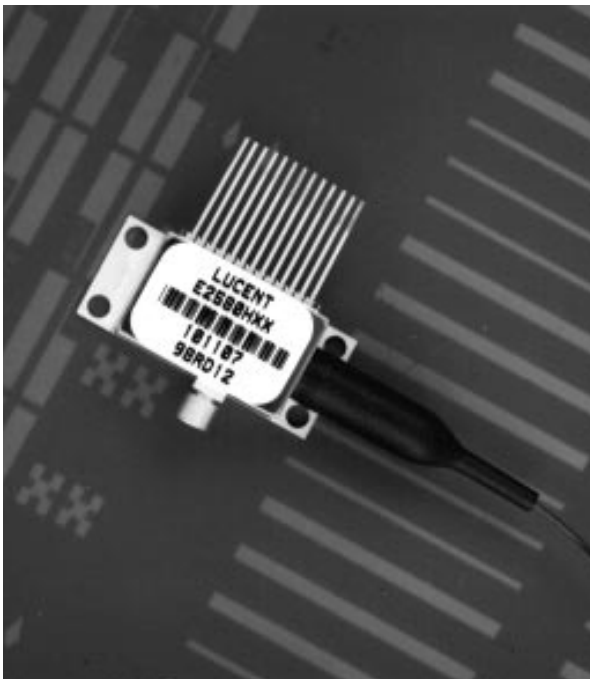

### Description

The E2560 EML (without integral driver IC) and E2580 EML (with integral driver IC) are designed for 10 Gbits/s DWDM or TDM transmission applications. They integrate a CW laser with an electroabsorptive modulator in the same semiconductor chip and are an extension of Lucent Technologies Microelectronics Group's existing E2500-series of devices. Both types use a small-profile Gilbert GPO connector to handle the RF signal. To ensure that sufficient optical power reaches the receiver, the devices are typically coupled with an erbium-doped fiber amplifier, such as Lucent's 1724-series. These devices can replace external modulators that are often bulkier, more expensive, and require more complex drive electronics than the EML. Both the E2560 and E2580 are available for transmission distances of 40 km and 80 km. The package also contains a thermoelectric cooler, thermistor, rear-facet monitor photodiode, and an optical isolator.

**Description** (continued)

The nominal input impedance of the E2560 version is 50 Ω. The package is qualified to the Bellcore TA-TSY-000468 standard.

Both E2560 and E2580 are available in a range of ITU-T wavelengths for use in DWDM systems operating at 10 Gbits/s per channel. The device has excellent wavelength stability, supporting operation at 100 GHz channel spacing over 20 years (assuming an end-of-life aging condition of  $\pm 100$  pm). Typically, no external wavelength stabilization is required in systems of this type, using Lucent's E2500 series EMLs. The package also offers excellent stability of wavelength vs. case temperature, with a maximum coefficient of  $\pm 0.5$  pm/°C.

**Module Characteristics**

**Table 1. Module Characteristics**

Parameter	Description
Package Type	E2560: 7-pin package with GPO connector RF input. E2580: 13-pin package with GPO connector RF input.
Fiber	Standard single-mode fiber.
Connector	ST <sup>®</sup> ; other connectors available on request.
RF Input Impedance	50 Ω.
Bit Rate	10 Gbits/s.

**Pin Information**

**Table 2. Pin Descriptions**

E2560			E2580		
Pin	Abbreviation	Definition	Pin	Abbreviation	Definition
—	—	—	13	TEC-	Thermoelectric cooler-
—	—	—	12	TEC+	Thermoelectric cooler+
—	—	—	11	Vss	Voltage supply to the IC
—	—	—	10	DCA	Duty cycle adjust
—	—	—	9	OA	Optical amplitude adjust
—	—	—	8	NC	No connect/reserved
7	TEC-	Thermoelectric cooler-	7	NC	No connect/reserved
6	TEC+	Thermoelectric cooler+	6	VEA	Modular offset (on-state)
5	BACK DET+	Monitor cathode (+)	5	BACK DET+	Monitor cathode (+)
4	BACK DET-	Monitor anode (-)	4	BACK DET-	Monitor anode (-)
3	LASER+	Laser anode	3	LASER+	Laser anode
2	THERM	Thermistor	2	THERM	Thermistor
1	THERM, LASER-, CASE	Combined thermistor/ laser cathode/case	1	THERM, LASER-, CASE	Combined thermistor/ laser cathode/case

Note: For full details of pin functions and required bias levels for the version with the IC, refer to *E2580 EML with Integral Driver IC: Pin Definitions And Operation* Application Note (TBD).

## Target Specifications

### Absolute Maximum Ratings

Stresses in excess of the absolute maximum ratings can cause permanent damage to the device. These are absolute stress ratings only. Functional operation of the device is not implied at these or any other conditions in excess of those given in the operational sections of the data sheet. Exposure to absolute maximum ratings for extended periods can adversely affect device reliability.

**Table 3. Absolute Maximum Ratings**

Parameter	Conditions	Limit	Unit
Laser Diode Reverse Voltage	CW	2	V
Laser Diode Forward Current	CW	150	mA
Optical Output Power	CW	10	mW
Modulator Reverse Voltage	—	5	V
Modulator Forward Voltage	—	1	V
Monitor Diode Reverse Voltage	—	10	V
Monitor Diode Forward Voltage	—	1	V
Storage Temperature	—	-40 to +85	°C
Operating Temperature	—	-10 to +70	°C

### Characteristics

**Table 4. Optical and Electrical Specifications** (Chip operating temp. = 15 °C to 35 °C, except where noted.)

Parameter	Symbol	Conditions	Min	Max	Unit
Threshold Current (BOL)	$I_{TH}$	—	5	35	mA
Forward Voltage	$V_F$	$I_F = I_{OP} @ T_{OP}$	—	2.2	V
Operating Current	$I_{OP}$	—	50	100	mA
Threshold Power	$P_{TH}$	$I_F = I_{TH}$ $V_M = I_{OP}$	—	80	$\mu W$
Fiber Output Power (Peak)	$P_{PK}$	$V_M = 0 V$ $I_F = I_{OP}$	1	—	dBm
Peak Wavelength (Wavelength can be specified to the ITU wavelength channels.)	$\lambda_{PK}$	$V_M = 0 V$ $T_{LASER CHIP} = T_{OP}$ $I_F = I_{OP}$	1530	1563	nm
Side-mode Suppression Ratio	SMSR	$V_M = 0 V$ $I_F = I_{OP}, T_{OP}$	30	—	dB
Dispersion Penalty $BER = 10^{-10}$	DP	10 Gbits/s* $V_{LOW} = -1.5 \text{ to } -3.0 V,$ $V_{HIGH} = 0 V \text{ to } -1 V$ $I_F = I_{OP} @ T_{OP}$	—	2.0	dB

\* Over 720 ps/nm (40 km version), 1080 ps/nm (60 km version), 1440 ps/nm (80 km version).

**Target Specifications** (continued)**Table 4. Optical and Electrical Specifications** (Chip operating temp. = 15 °C to 35 °C, except where noted.)  
(continued)

Parameter	Symbol	Conditions	Min	Max	Unit
<b>Modulator/Driver</b>					
Extinction Ratio	ER <sub>RF</sub>	V <sub>IN</sub> = 0.5 Vp-p to 1.0 Vp-p 10 Gbits/s (E2580) V <sub>M</sub> = 0 V to -2.5 V 10 Gbits/s (E2560)	10	—	dB
RF Return Loss (E2560) (0 GHz to 6 GHz)	S <sub>11</sub>	V <sub>M</sub> = -1 V I <sub>F</sub> = I <sub>OP</sub>	10	—	dB
RF Return Loss (E2560) (6 GHz to 8 GHz)	S <sub>11</sub>	V <sub>M</sub> = -1 V I <sub>F</sub> = I <sub>OP</sub>	7	—	dB
RF Return Loss (E2560) (8 GHz to 10 GHz)	S <sub>11</sub>	V <sub>M</sub> = -1 V I <sub>F</sub> = I <sub>OP</sub>	5	—	dB
-3 dB Bandwidth (E2560)	BW	V <sub>M</sub> = -1 V I <sub>F</sub> = I <sub>OP</sub>	11	—	GHz
RF Return Loss (E2560) (0 GHz to 10 GHz)	S <sub>11</sub>	V <sub>IN</sub> = 0.5 Vp-p to 1.0 Vp-p 10 Gbits/s	10	—	dB
Input Voltage (E2580) (Peak to Peak) (ac coupled input)	V <sub>IN</sub>	—	0.5	1.0	V
Rise/Fall Time (20%—80%)	tr/TF	—	—	40	ps
<b>Monitor Diode</b>					
Monitor Current	I <sub>BD</sub>	V <sub>BD</sub> = 5 V I <sub>F</sub> = I <sub>OP</sub>	40	1100	μA
Dark Current	I <sub>D</sub>	V <sub>BD</sub> = 5 V	—	0.1	μA
Capacitance	C	V <sub>BD</sub> = 5 V F = 1 MHz	—	25	pF
<b>Thermistor</b>					
Resistance	R <sub>THERM</sub>	T = 25 °C	9.5	10.5	kΩ
Thermistor Current	I <sub>TC</sub>	—	10	100	μA
Thermistor B Constant	B	—	3700	4100	—
<b>Thermoelectric Cooler</b>					
TEC Current	I <sub>TEC</sub>	—†	—	1.1	A
TEC Voltage	V <sub>TEC</sub>	—†	—	2.6	V
TEC Power	P <sub>TEC</sub>	—†	—	2.9	W
TEC Capacity	ΔT	—†	55	—	C
<b>Optical Isolation</b>					
Optical Isolation	—	—†	30	—	dB
<b>Package</b>					
Wavelength vs. Case Temp.	dλ/ dT	T <sub>CASE</sub> = -10 °C to +70 °C	-0.5	0.5	pm/°C

\* Over 720 ps/nm (40 km version), 1080 ps/nm (60 km version), 1440 ps/nm (80 km version).

† T<sub>CASE</sub> = 70 °C, T<sub>laser chip</sub> = 15 °C to 35 °C (E2560), 20 °C to 35 °C (E2580).

Outline Diagram

E2560

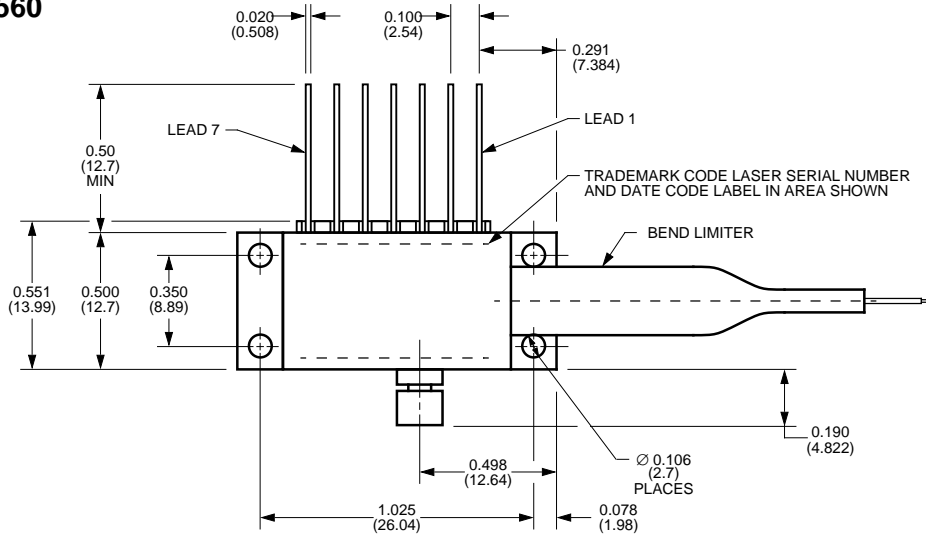

E2580

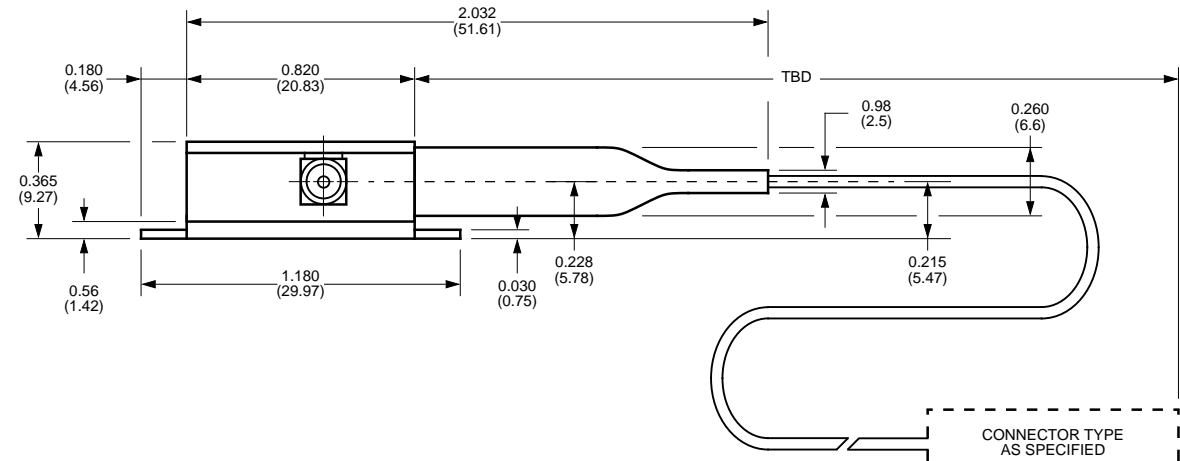
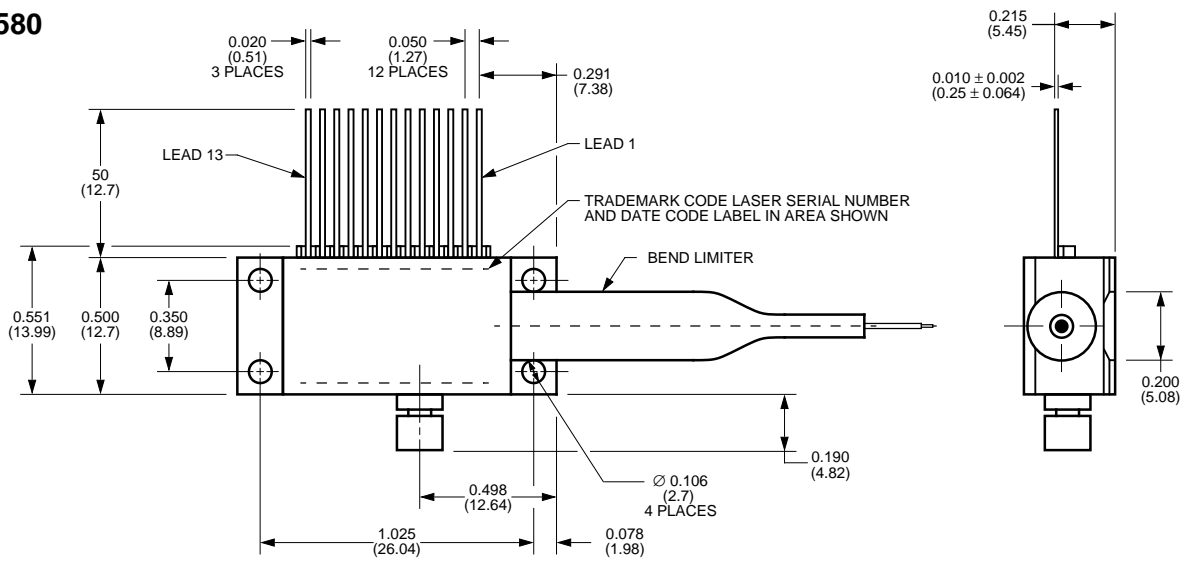

1-1006(F).r1

### Laser Safety Information

Class IIIb Laser Product

This product complies with 21 CFR 1040.10 and 1040.11.

Single-mode connector

Wavelength = 1.5  $\mu$ m

Maximum power = 10 mW

Because of size constraints, laser safety labeling is not affixed to the module but attached to the outside of the shipping carton.

Product is not shipped with power supply.

**Caution:** Use of controls, adjustments, and procedures other than those specified herein may result in hazardous laser radiation exposure.

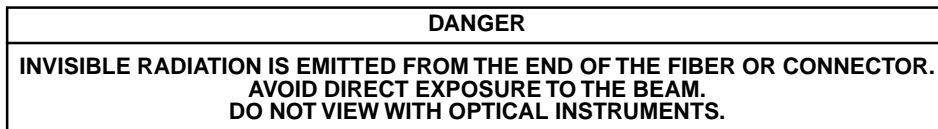
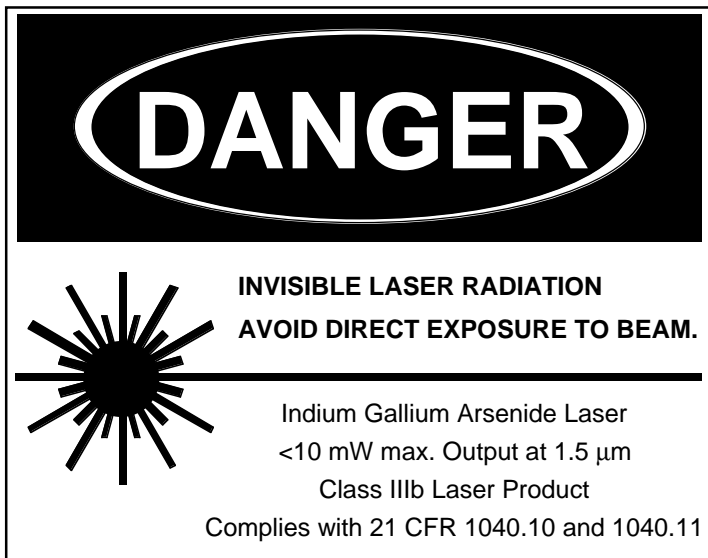

## Ordering Information

Table 5. Ordering Information

Parameter		Device Description							
ITU-T Wave-length (nm)	Freq.	E2560 Series, 40 km, without IC		E2561 Series, 60 km, without IC		E2580 Series, 40 km, with IC		E2581 Series, 80 km, with IC	
		Code	Comcode	Code	Comcode	Code	Comcode	Code	Comcode
1530.33	195.9	E2560H59	108414722	E2561H59	108587791	E2580H59	108415183	E2581H59	108588211
1531.12	195.8	E2560H58	108414780	E2561H58	108587783	E2580H58	108415191	E2581H58	108588195
1531.90	195.7	E2560H57	108414798	E2561H57	108587775	E2580H57	108415209	E2581H57	108588203
1532.68	195.6	E2560H56	108414806	E2561H56	108587767	E2580H56	108415217	E2581H56	108588187
1533.47	195.5	E2560H55	108414814	E2561H55	108587759	E2580H55	108415225	E2581H55	108588179
1534.25	195.4	E2560H54	108414822	E2561H54	108587742	E2580H54	108415233	E2581H54	108588161
1535.04	195.3	E2560H53	108414830	E2561H53	108587734	E2580H53	108415241	E2581H53	108588153
1535.82	195.2	E2560H52	108414848	E2561H52	108587726	E2580H52	108415258	E2581H52	108588146
1536.61	195.1	E2560H51	108414855	E2561H51	108587718	E2580H51	108415266	E2581H51	108588138
1537.40	195.0	E2560H50	108414863	E2561H50	108587700	E2580H50	108415274	E2581H50	108588120
1538.19	194.9	E2560H49	108414871	E2561H49	108587692	E2580H49	108415282	E2581H49	108588112
1538.98	194.8	E2560H48	108414889	E2561H48	108587676	E2580H48	108415290	E2581H48	108588104
1539.77	194.7	E2560H47	108415142	E2561H47	108587668	E2580H47	108415308	E2581H47	108588096
1540.56	194.6	E2560H46	108414897	E2561H46	108587650	E2580H46	108415316	E2581H46	108588088
1541.35	194.5	E2560H45	108414905	E2561H45	108587635	E2580H45	108415324	E2581H45	108588062
1542.14	194.4	E2560H44	108414913	E2561H44	108587627	E2580H44	108415332	E2581H44	108588054
1572.94	194.3	E2560H43	108414921	E2561H43	108587585	E2580H43	108415340	E2581H43	108588047
1543.73	194.2	E2560H42	108414939	E2561H42	108587577	E2580H42	108415357	E2581H42	108588039
1544.53	194.1	E2560H41	108414947	E2561H41	108587569	E2580H41	108415365	E2581H41	108588021
1545.32	194.0	E2560H40	108414954	E2561H40	108587544	E2580H40	108415373	E2581H40	108588013
1546.12	193.9	E2560H39	108414962	E2561H39	108587536	E2580H39	108415381	E2581H39	108588005
1546.92	193.8	E2560H38	108414970	E2561H38	108587528	E2580H38	108415399	E2581H38	108587999
1547.72	193.7	E2560H37	108414988	E2561H37	108587510	E2580H37	108415407	E2581H37	108587981
1548.51	193.6	E2560H36	108414996	E2561H36	108587502	E2580H36	108415415	E2581H36	108587973
1549.32	193.5	E2560H35	108415001	E2561H35	108587411	E2580H35	108415423	E2581H35	108587965
1550.12	193.4	E2560H34	108415019	E2561H34	108587403	E2580H34	108415431	E2581H34	108587957
1550.92	193.3	E2560H33	108415027	E2561H33	108587395	E2580H33	108415449	E2581H33	108587940
1551.72	193.2	E2560H32	108415035	E2561H32	108587387	E2580H32	108415456	E2581H32	108587932
1552.52	193.1	E2560H31	108415043	E2561H31	108587379	E2580H31	108415464	E2581H31	108587924
1553.33	193.0	E2560H30	108415050	E2561H30	108587353	E2580H30	108415472	E2581H30	108587916
1554.13	192.9	E2560H29	108415068	E2561H29	108587346	E2580H29	108415480	E2581H29	108587908
1554.94	192.8	E2560H28	108415076	E2561H28	108587338	E2580H28	108415498	E2581H28	108587890
1555.75	192.7	E2560H27	108415084	E2561H27	108587320	E2580H27	108415506	E2581H27	108587882
1556.56	192.6	E2560H26	108415092	E2561H26	108587312	E2580H26	108415514	E2581H26	108587874
1557.36	192.5	E2560H25	108415100	E2561H25	108587304	E2580H25	108415522	E2581H25	108587866
1558.17	192.4	E2560H24	108415118	E2561H24	108587296	E2580H24	108415530	E2581H24	108587858
1558.98	192.3	E2560H23	108415126	E2561H23	108587288	E2580H23	108415548	E2581H23	108587841
1559.79	192.2	E2560H22	108415134	E2561H22	108587262	E2580H22	108415555	E2581H22	108587833
1560.61	192.1	E2560H21	108415159	E2561H21	108587254	E2580H21	108415563	E2581H21	108587825
1561.42	192.0	E2560H20	108415167	E2561H20	108587247	E2580H20	108415571	E2581H20	108587817
1562.23	191.9	E2560H19	108415175	E2561H19	108587239	E2580H19	108415589	E2581H19	108587809
1530.60	—	E2560H	108422494	E2561H	108592551	E2580H	108422510	E2581H	108592569

---

For additional information, contact your Microelectronics Group Account Manager or the following:

INTERNET: <http://www.lucent.com/micro>, or for Optoelectronics information, <http://www.lucent.com/micro/opto>

E-MAIL: [docmaster@micro.lucent.com](mailto:docmaster@micro.lucent.com)

N. AMERICA: Microelectronics Group, Lucent Technologies Inc., 555 Union Boulevard, Room 30L-15P-BA, Allentown, PA 18103  
**1-800-372-2447**, FAX 610-712-4106 (In CANADA: **1-800-553-2448**, FAX 610-712-4106)

ASIA PACIFIC: Microelectronics Group, Lucent Technologies Singapore Pte. Ltd., 77 Science Park Drive, #03-18 Cintech III, Singapore 118256  
**Tel. (65) 778 8833**, FAX (65) 777 7495

CHINA: Microelectronics Group, Lucent Technologies (China) Co., Ltd., A-F2, 23/F, Zao Fong Universe Building, 1800 Zhong Shan Xi Road, Shanghai 200233 P. R. China **Tel. (86) 21 6440 0468, ext. 316**, FAX (86) 21 6440 0652

JAPAN: Microelectronics Group, Lucent Technologies Japan Ltd., 7-18, Higashi-Gotanda 2-chome, Shinagawa-ku, Tokyo 141, Japan  
**Tel. (81) 3 5421 1600**, FAX (81) 3 5421 1700

EUROPE: Data Requests: MICROELECTRONICS GROUP DATALINE: **Tel. (44)7000 582 368**, FAX (44) 1189 328 148  
Technical Inquiries: OPTOELECTRONICS MARKETING: **(44) 1344 865 900** (Ascot UK)

---

Lucent Technologies Inc. reserves the right to make changes to the product(s) or information contained herein without notice. No liability is assumed as a result of their use or application. No rights under any patent accompany the sale of any such product(s) or information. *ST* is a registered trademark of Lucent Technologies Inc.

Copyright © 1999 Lucent Technologies Inc.  
All Rights Reserved

August 1999  
DS99-305LWP (Replaces DS99-078LWP)

microelectronics group

Lucent Technologies  
Bell Labs Innovations

