



# Integrated Low Profile Transceiver Module for Low Power Applications

## 9. 6 kbit/s to 1.152 Mbit/s Data Transmission Rate



### Description

The miniaturized TFBS5600<sup>1)</sup> and TFBS5607<sup>1)</sup> are ideal transceivers for applications in telecommunications like mobile phones, pagers, and PDAs of all kinds. The devices are both designed for optimum performance and minimum package size.

These devices cover the latest IrDA<sup>®</sup> physical layer specification for SIR and MIR 1.152 Mbit/s IrDA<sup>®</sup> mode.

Both transceivers are in a very low profile package, allowing to replace and upgrade a variety of common SIR devices to MIR functionality with the additional feature of variable logic voltage swing. The TFBS5607 is using the Vishay Telefunken, IBM<sup>®</sup> and Infineon<sup>®</sup> order of the pinning, the TFBS5600 is equivalent to the HSDL – 3202 (SIR device) pinning.

### Features

- Packages:  
–TFBS5607 Vishay Legacy Pinning Order  
–TFBS5600 Pinning like HSDL–3201  
with added functionality
- Compatible to IrDA Low Power Standard (MIR and SIR with Lowest Current Consumption)
- Wide Supply Voltage Range (2.4 V to 5.5 V)
- Operational down to 2.0 V
- **Logic Input and Output Voltage 1.5 V to 5.5 V**
- Tri – State – Receiver Output with weak pull-up efficient in shut down mode
- Lowest Power Consumption, typically 500  $\mu$ A in Receive Mode, <1  $\mu$ A in Shutdown Mode
- Only typical 60 mA Average Current Consumption in 1.152 Mbit/s Transmit Mode
- Fewest External Components
- Vishay's well known High EMI Immunity
- Eye Safety Protection Integrated

### Applications

- Mobile Phones, Pagers, Hand-held Battery Operated Equipment
- Computers (WinCE, PalmPC, PDAs)
- Digital Still and Video Cameras
- Extended IR Adapters
- Medical and Industrial Data Collection

1) Customized version with different current control setting for IrDA Low Power standard can be selected, too.

## Packages

TFBS5600/ TFBS5607  
PC Board

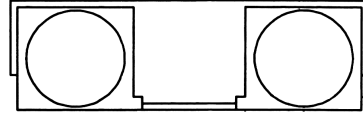
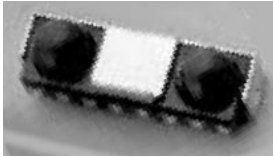

## Ordering Information

Part Number	Qty / Reel	Description
TFBS5600-TR3	2500 pcs	
TFBS5607-TR3	2500 pcs	

## Functional Block Diagram

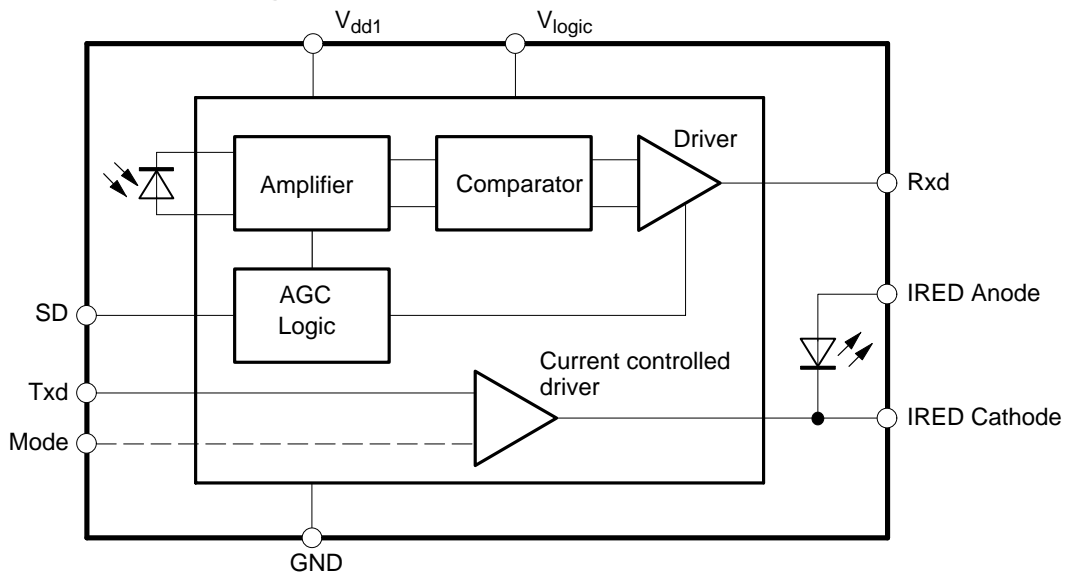
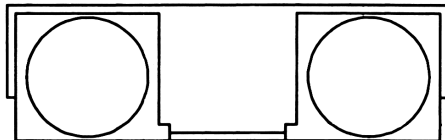

Figure 1. Functional Block Diagram  
(mode input is for internal current selection of customized version for low power or full IrDA range)

## Pin Description

Pin	Pin	Function	Description	I/O	Active
TFBS5600	TFBS5607				
8	1	IREDA	IREDA Anode to be externally connected to $V_{CC}$ through a current control resistor. This pin is allowed to be supplied from an uncontrolled power supply separated from the controlled $V_{CC}$ supply. Described in US patent 08995536		
	2	IREDC	IREDA Cathode, internally connected to driver transistor		
4		AGND	Analog Ground, to be externally connected to Ground		
7	3	Txd	Transmit Data Input	I	HIGH
6	4	Rxd	Received Data Output, push-pull CMOS driver output capable of driving a standard CMOS or TTL load. No external pull-up or pull-down resistor is required. Pin is connected to $V_{logic}$ with a weak pull-up (500 k $\Omega$ ) when device is in shutdown mode. Rxd output is quiet during transmission.	O	LOW
5	5	SD	Shutdown, <b>will switch the device into shutdown after a delay of 1 ms</b>	I	HIGH
3	6	Vdd	Supply Voltage		
2	7	$V_{logic}$	Defines the input and output logic swing voltage	I	
1	8	GND	Ground		

**TFBS5600**  
Second source pinning



1

Pin order:  
IREDA IREDC Txd Rxd SD Vdd  $V_{logic}$  GND

**TFBS5607**  
Vishay legacy pinning

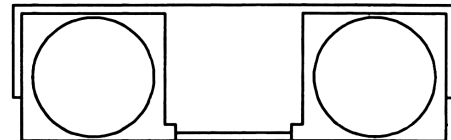

1

Pin order:  
GND  $V_{logic}$  Vdd AGND SD Rxd Txd IREDA

Figure 2. Pinning

### Absolute Maximum Ratings

Reference Point Ground, Pin 8, unless otherwise noted

Parameters	Test Conditions	Symbol	Min.	Typ.	Max.	Unit
Supply Voltage Range	$0\text{ V} < V_{dd2} < 6\text{ V}$	$V_{dd1}$	-0.5		6	V
	$0\text{ V} < V_{dd1} < 6\text{ V}$	$V_{dd2}$	-0.5		6	V
	$0\text{ V} < V_{dd1} < 6\text{ V}$	$V_{logic}$	-0.5		6	V
	$0\text{ V} < V_{dd2} < 6\text{ V}$					
Input Current	all pins (IRED Anode excluded)				10	mA
Output Sink Current, Rxd	Rxd				25	mA
Rep. Pulsed IRED Current	IRED Anode, $t_{on} < 20\%, < 20\ \mu\text{s}$	$I_{IRED(RP)}$			500	mA
Average IRED Current		$I_{IRED(DC)}$			125	mA
Power Dissipation		$P_{tot}$			450	mW
Junction Temperature		$T_J$			125	°C
Ambient Temperature Range (Operating)		$T_{amb}$	-25		85	°C
Storage Temperature Range		$T_{stg}$	-25		85	°C
Soldering Temperature	$t = 20\text{ s @ }215^\circ\text{C}$			215	240	°C
Transmitter Data and Shutdown Input Voltage	$2.4\text{ V} < V_{dd1} < 5.5\text{ V}$	$V_{Txd}, V_{SD}$	-0.5		6	V
Receiver Data Output Voltage		$V_{Rxd}$	-0.5		$V_{logic}+0.5$	V
Virtual source size	Method: (1-1/e) encircled energy	d	2.5	2.8		mm
Max. Intensity for Class 1 operation of IEC 825 or EN60825	EN60825, 1.1.1997 Worst case IrDA pulse pattern, lab. conditions.				save in all operation modes*)	mW/sr

- \*) The device is protected against Txd short by an internal shut-off when the pulse duration is exceeding maximum IrDA specification value of pulse duration. In addition the max. current is limited. When using an additional current control resistor the device is fully protected equivalent to IEC 60825-1, amendment 2, edition 01.01.2001

**Optoelectronic Characteristics**

$T_{amb} = 25^{\circ}\text{C}$ ,  $V_{dd1} = 2.4\text{ V to }5.5\text{ V}$  unless otherwise noted.

Typical values are for DESIGN AID ONLY, not guaranteed nor subject to production testing.

Parameters	Test Conditions	Symbol	Min.	Typ.	Max.	Unit
<b>Transceiver</b>						
Supported Data Rates Rxd pulse duration 400 ns	Base band MIR		9.6		1152	kbit/s
Supply Current receive mode	$V_{dd1} = 2.4\text{ V to }5.5\text{ V}$	$I_S$			900	$\mu\text{A}$
Supply Current shutdown mode	$V_{dd1} = 2.4\text{ V to }5.5\text{ V}$	$I_{SSD}$		0.1	1	$\mu\text{A}$
Average Supply Current during transmission	$I_{IREDpeak} = 450\text{ mA}$ , no external resistor, IrDA full range	$I_S$		60	120	mA
Shutdown / Mode clock pulse duration		$t_{prog}$	0.2		20	$\mu\text{s}$
Shutdown delay "Receive off"		$t_{prog}$	1		1.5	ms
Shutdown delay "Receive on"		$t_{prog}$	40		100	$\mu\text{s}$
Transceiver "Power on" Settling Time	Time from switching on $V_{dd1}$ to established specified operation			50		$\mu\text{s}$

### Optoelectronic Characteristics

$T_{amb} = 25^{\circ}\text{C}$ ,  $V_{dd1} = 2.4\text{ V to }5.5\text{ V}$  unless otherwise noted.

Typical values are for DESIGN AID ONLY, not guaranteed nor subject to production testing.

Parameters	Test Conditions	Symbol	Min.	Typ.	Max.	Unit
<b>Receiver</b>						
Minimum Detection Threshold Irradiance 9.6 kbit/s to 1.152 Mbit/s *)	$ \alpha  \leq \pm 15^{\circ}$ $V_{dd1} = 2.4\text{ V to }5.5\text{ V}$	$E_{e, \text{min}}$		40	80	mW/m <sup>2</sup>
Maximum Detection Threshold Irradiance	$ \alpha  \leq \pm 90^{\circ}$ $V_{dd1} = 5\text{ V}$	$E_{e, \text{max}}$		5000		W/m <sup>2</sup>
	$ \alpha  \leq \pm 90^{\circ}$ $V_{dd1} = 3\text{ V}$	$E_{e, \text{max}}$	8000	15000		W/m <sup>2</sup>
Logic Low Receiver Input Irradiance		$E_{e, \text{max, low}}$	4			mW/m <sup>2</sup>
Output Voltage Rxd	active $C = 15\text{ pF}$ , $R = 2.2\text{ k}\Omega$	$V_{OL}$		0.5	0.8	V
	non active $C = 15\text{ pF}$ , $R = 2.2\text{ k}\Omega$	$V_{OH}$	$V_{dd1}-0.5$			V
Output Current Rxd $V_{OL} < 0.8\text{ V}$					4	mA
Rise Time @Load: $C = 15\text{ pF}$ , $R = 2.2\text{ k}\Omega$	$1.5\text{ V} \leq V_{\text{logic}} < 1.8\text{ V}$	$t_r$		30		ns
Fall Time @Load: $C = 15\text{ pF}$ , $R = 2.2\text{ k}\Omega$	$1.5\text{ V} \leq V_{\text{logic}} < 1.8\text{ V}$	$t_f$		30		ns
Rise Time @Load: $C = 15\text{ pF}$ , $R = 2.2\text{ k}\Omega$	$1.8\text{ V} \leq V_{\text{logic}} < 5.5\text{ V}$	$t_r$		25	40	ns
Fall Time @Load: $C = 15\text{ pF}$ , $R = 2.2\text{ k}\Omega$	$1.8\text{ V} \leq V_{\text{logic}} < 5.5\text{ V}$	$t_f$		25	40	ns
Rxd Signal Electrical Output Pulse Width	$1.5\text{ V} \leq V_{\text{logic}} < 5.5\text{ V}$	$t_p$	250	400	550	ns
Latency	MIR mode	$t_L$		50	200	$\mu\text{s}$

\*) Rxd output pulse duration nominal 400 ns for all speeds.

**Optoelectronic Characteristics** $T_{amb} = 25\text{ }^{\circ}\text{C}$ ,  $V_{dd1} = 2.4\text{ V}$  to  $5.5\text{ V}$  unless otherwise noted.

Typical values are for DESIGN AID ONLY, not guaranteed nor subject to production testing.

Parameters	Test Conditions	Symbol	Min.	Typ.	Max.	Unit
<b>Transmitter</b>						
Logic CMOS High/Low Decision Threshold		$V_{IL}(\text{Txd})$		$1/2 \times V_{logic}$		V
Logic Low Transmitter Input Voltage		$V_{IL}(\text{Txd})$	0		0.2*) $V_{logic}$	V
Logic High Transmitter Input Voltage	$1.5\text{ V} < V_{logic} < 5.5\text{ V}$	$V_{IH}(\text{Txd})$	0.8*) $V_{logic}$		$V_{logic} + 0.5$	V
Output Radiant Intensity, $ \alpha  \leq 15^{\circ}$ MIR level full IrDA range	$V_{dd2} = 2.7\text{ V}$ ( $I_F = 450\text{ mA}$ )	$I_e$	40	90		mW/sr
Controlled IRED drive peak current*)	$V_{dd2} = 2.7\text{ V}$ to $V_{dd2} = 5.5\text{ V}$			450		mA
Maximum Output Pulse width (eye safety protection)	$P_{WI} > 23\text{ }\mu\text{s}$	$P_{W0min}$	23		80	$\mu\text{s}$
Optical Pulse width	$P_{WI} > 1.6\text{ }\mu\text{s}$	$P_{W0}$	1.45		1.75	$\mu\text{s}$
	$P_{WI} > 217\text{ ns}$	$P_{W0}$	210		226	ns
Optical Rise/Falltime		$t_r, t_f$			40	ns
Peak Wavelength of Emission		$\lambda_p$	880		900	nm
Spectral Optical Radiation Bandwidth		$\Delta\lambda$		45		nm
Output Radiant Intensity	Txd logic low level	$I_e$			0.04	$\mu\text{W/sr}$
Overshoot, Optical					25	%
Rising Edge Peak to Peak Jitter		$t_j$			0.2	$\mu\text{s}$

\*) The current through the IRED can be defined also by an external resistor, internal current limitation to 450 mA peak, nominal. For operating above 4 V an external resistor is to be used for internal power dissipation reduction





## Identification

The identification of the device can be recalled by setting the SD active followed by activating Txd for a short period. With the low going edge of Txd a single pulse is generated at Rxd.

The SD is intended to activate the shutdown function after a delay of 1 ms. Therefore the full sequence should be run with that 1 ms time limitation, see drawing.

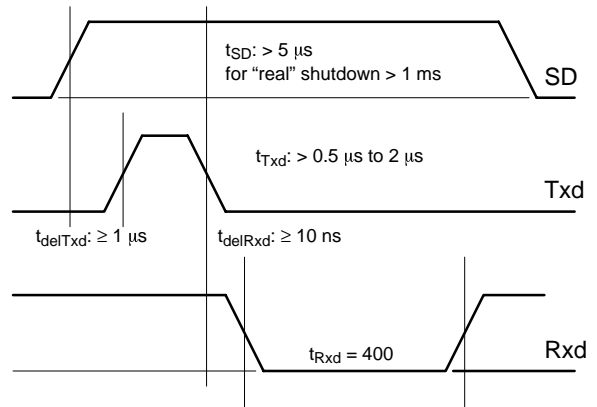

Figure 6.

## V<sub>logic</sub> Setting

The logic voltage swing is set by applying an external voltage to the V<sub>logic</sub> pin.

Table 1. Truth table

Inputs			Outputs	
SD	Txd	Optical input Irradiance mW/ m <sup>2</sup>	Rxd	LED drive current resulting intensity I <sub>e</sub> in mW/ sr
high < 1 ms	pulse	x	low going Txd triggers monostable to edit a 400 ns low pulse	0
high > 1 ms	x	x	floating (500 kΩ to V <sub>dd</sub> )	0
low	high	x	high	> 10
low	high > 80 μs	x	high	0
low	low	< 4	high	0
low	low	≥ 40	low, edge triggered pulse of 400 ns duration	0

### TFBS5600 (Mechanical Dimensions)

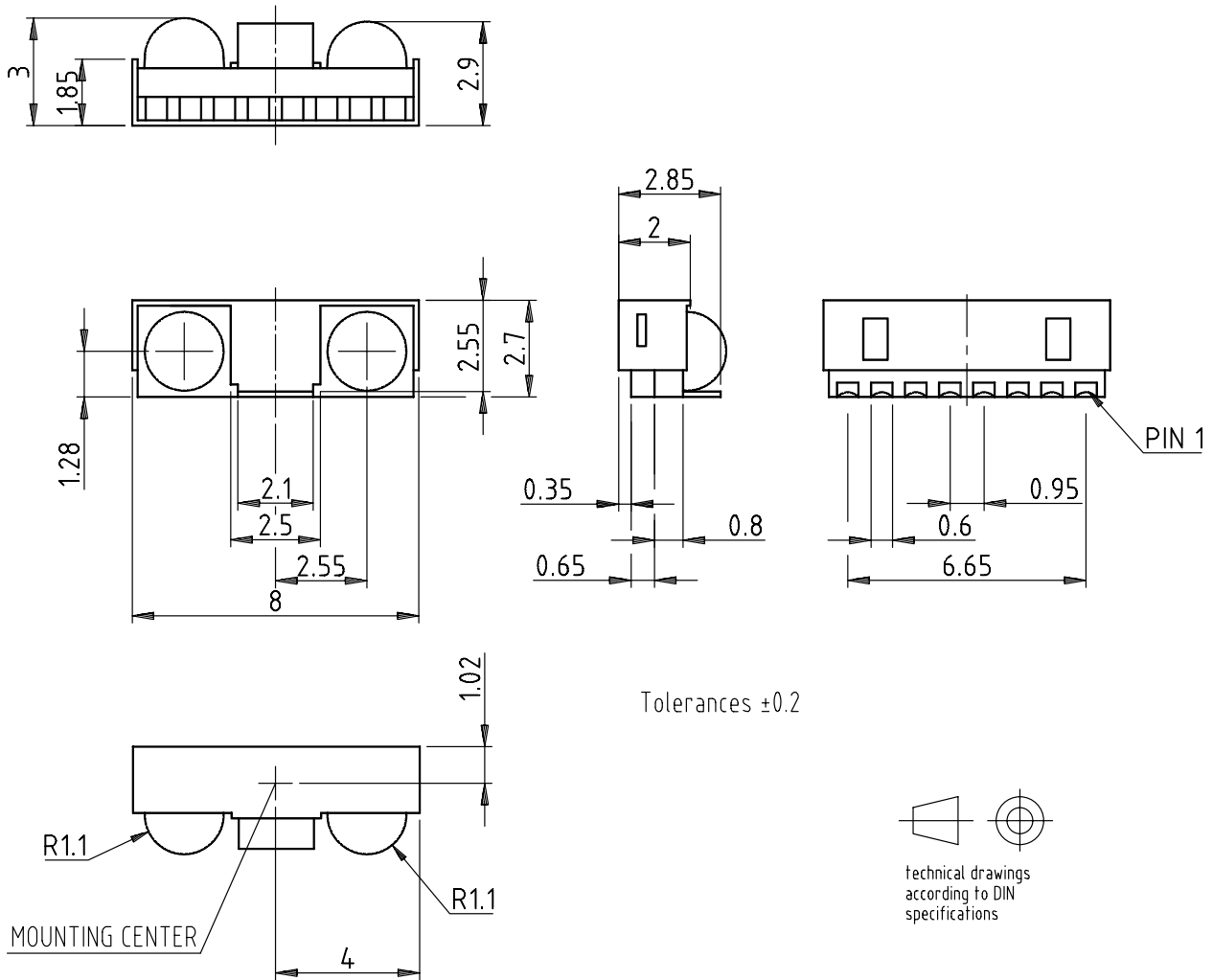

Drawing-No.: 6.550-5227.01-4

Issue: 1; 29.09.00

Dimensions in mm

16504

**TFBS5607 (Mechanical Dimensions)**

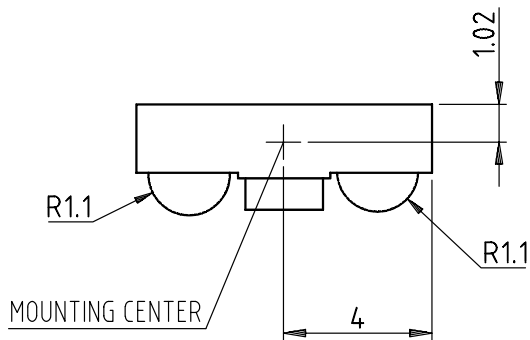
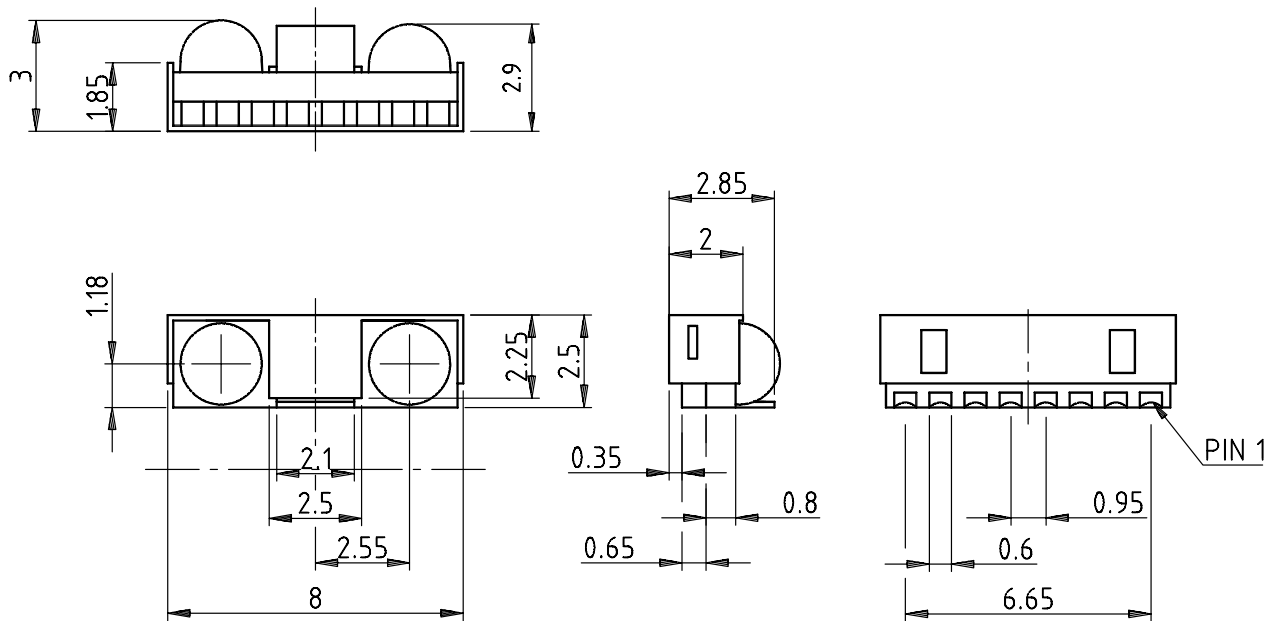

Tolerances  $\pm 0.2$

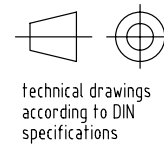

Drawing-No.: 6.550-5226.01-4

Issue: 1; 29.09.00

Dimensions in mm

16503

### Appendix

#### Application Hints

#### Recommended Circuit Diagram TFBS5600, TFBS5607

The TFBS5600 and TFBS5607 do not need any external components when operated at a "clean" power supply. In a more noisy ambient it is recommended to add a combination of a resistor and capacitor (R1, C1, C2) for noise suppression as shown in the figure below. A combination of an electrolytic for the low frequency range and a ceramic capacitor for suppressing the high frequency disturbance will be most effective. The capacitor C3 is only necessary when inductive wiring is used or the power supply cannot deliver the operating peak pulse current. However, a low impedance layout is the better and more cost efficient solution.

The inputs TXD and SD are high impedance CMOS inputs. Therefore, the lines from the I/O to those inputs should be carefully designed not to pick up ambient noise. If long lines are used, loads at the Txd input of the TFBS560x and at the Rxd input of the controller (!) are recommended. At the IRED Anode voltage supply line an additional capacitor might be necessary when inductive wiring is used. For adjusting the intensity depending on the application, a serial in the Vcc2 supply to the IRED Anode pin can be used.

For standard computer power supplies as first approach the recommended values from table 1 should be taken.

#### Shut Down

To shut down the TFBS5600 into a standby mode the SD pin has to be set active. After a delay of < 1 ms it will switch to the standby mode.

#### Latency

The receiver is in specified conditions after the defined latency. In a UART related application after that time (typically 50  $\mu$ s) the receiver buffer of the UART must be cleared. Therefore, the transceiver has to wait at least the specified latency after receiving the last bit before starting the transmission to be sure that the corresponding receiver is in a defined state.

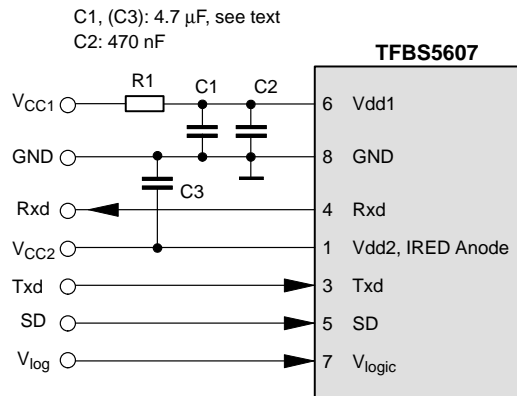

Figure 7. Recommended Application Circuit

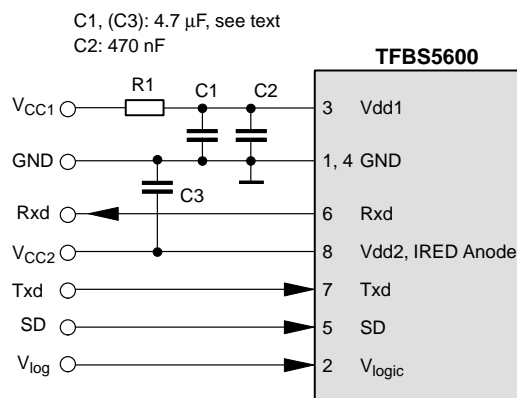

Figure 8. Recommended Application Circuit

Table 2. Recommended Application Circuit Components

Component	Recommended Value	Vishay Part Number
C1, C3	4.7 $\mu$ F, 16 V	293D 475X9 016B 2T
C2	0.47 $\mu$ F, Ceramic	VJ 1206 Y 104 J XXMT
R1	47 $\Omega$ , 0.125 W	CRCW-1206-47R0-F-RT1



**Revision History:**

A1.0, 25/02/2000: Target, 1<sup>st</sup> edition  
Derived from... 06/07 version

A0.9a, 19/04/2000: Target, tolerances for package height added, based on first mechanical package lots.

A1.0, 14/02/2001: Final revision

### Ozone Depleting Substances Policy Statement

It is the policy of **Vishay Semiconductor GmbH** to

1. Meet all present and future national and international statutory requirements.
2. Regularly and continuously improve the performance of our products, processes, distribution and operating systems with respect to their impact on the health and safety of our employees and the public, as well as their impact on the environment.

It is particular concern to control or eliminate releases of those substances into the atmosphere which are known as ozone depleting substances (ODSs).

The Montreal Protocol (1987) and its London Amendments (1990) intend to severely restrict the use of ODSs and forbid their use within the next ten years. Various national and international initiatives are pressing for an earlier ban on these substances.

**Vishay Semiconductor GmbH** has been able to use its policy of continuous improvements to eliminate the use of ODSs listed in the following documents.

1. Annex A, B and list of transitional substances of the Montreal Protocol and the London Amendments respectively
2. Class I and II ozone depleting substances in the Clean Air Act Amendments of 1990 by the Environmental Protection Agency (EPA) in the USA
3. Council Decision 88/540/EEC and 91/690/EEC Annex A, B and C (transitional substances) respectively.

**Vishay Semiconductor GmbH** can certify that our semiconductors are not manufactured with ozone depleting substances and do not contain such substances.

**We reserve the right to make changes to improve technical design and may do so without further notice.**

Parameters can vary in different applications. All operating parameters must be validated for each customer application by the customer. Should the buyer use Vishay Telefunken products for any unintended or unauthorized application, the buyer shall indemnify Vishay Telefunken against all claims, costs, damages, and expenses, arising out of, directly or indirectly, any claim of personal damage, injury or death associated with such unintended or unauthorized use.

Vishay Semiconductor GmbH, P.O.B. 3535, D-74025 Heilbronn, Germany  
Telephone: 49 (0)7131 67 2831, Fax number: 49 (0)7131 67 2423