

EE-SX460-P1

Photo IC Output with Snap-in Mounting Feature

- Unique snap-in mounting mechanism assures easy mounting and removal with no screws or nuts, even from above the mounting plate
- Model can be mounted to plates varying in thickness from 0.8 to 1.6 mm
- Photo IC receiver with Schmitt circuit assures a high output of 16 mA at 28 VDC and a high response speed of 3,000 p.p.s.
- Easy wiring with commercially available connector

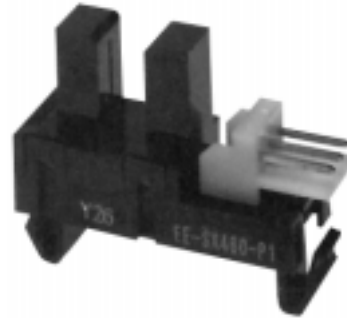

Ordering Information

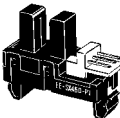
Appearance	Sensing method	Slot width	Slot depth	Output configuration	Weight	Applicable connector	Part number
	Transmissive	5 mm	10 mm	Light-ON	Approx. 3.0 g	EE-1005 Connector	EE-SX460-P1

Specifications

■ ABSOLUTE MAXIMUM RATINGS ($T_A = 25^\circ\text{C}$)

Item	Symbol	Rated value	
Supply voltage	V_{CC}	10 V	
Output voltage	V_{OUT}	28 V	
Output current	I_{OUT}	16 mA	
Permissible output dissipation	P_{OUT}	250 mW	
Ambient temperature	Operating	T_{opr}	-20°C to 75°C (-4°F to 167°F)
	Storage	T_{stg}	-40°C to 85°C (-40°F to 185°F)

■ CHARACTERISTICS ($T_A = 25^\circ\text{C}$, $V_{CC} = 5\text{V} \pm 10\%$)

Item	Symbol	Value	Condition
Low level output voltage	V_{OL}	0.3 V max.	$I_{OUT} = 16\text{ mA}$ with incident light
High level output voltage	V_{OH}	$(V_{CC} \times 0.9)\text{ V min.}$	$V_{OUT} = V_{CC}$; $R_L = 47\text{ k}\Omega$ (without incident light)
Current consumption	I_{CC}	30 mA max.	With or without incident light
Response frequency	f	3,000 P.P.S. min.	$V_{OUT} = V_{CC}$; $R_L = 47\text{ k}\Omega$

Note: The value of the response frequency is measured by rotating the disk as shown below.

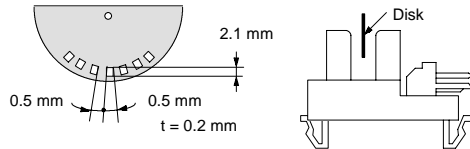

■ RECOMMENDED OPERATING CONDITION (WITHIN THE RATED TEMPERATURE RANGE)

Item	Symbol	Recommended value	Remarks
Supply voltage	V_{CC}	$5\text{V} \pm 10\%$	Refer to Engineering Data (Temperature Characteristics) and keep the output voltage and current as low as possible in the recommended range.
Output voltage	V_{OUT}	4.5 to 28 V	
Output current	I_{OUT}	16 mA max.	

Engineering Data

Note: The operating conditions of the photomicrosensor must be within the absolute maximum rating ranges.

■ TEMPERATURE CHARACTERISTICS

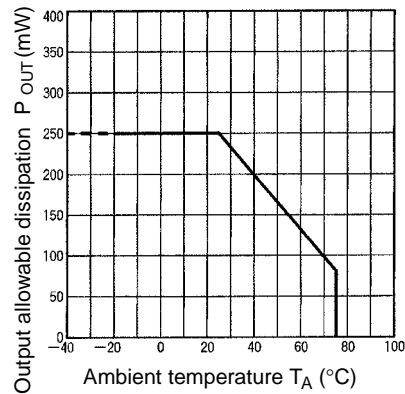

■ SENSING POSITION CHARACTERISTICS

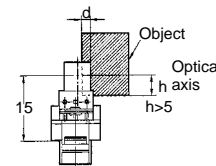
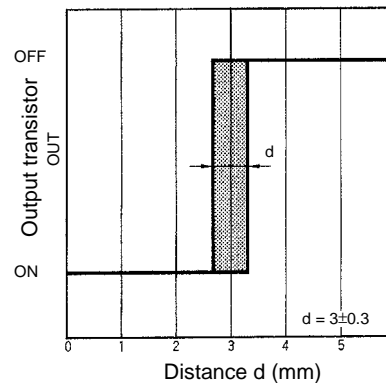

REPEATED SENSING POSITION CHARACTERISTICS

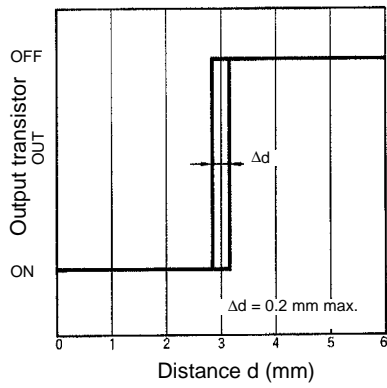

Operation

INTERNAL/EXTERNAL CIRCUIT DIAGRAM

Light-ON

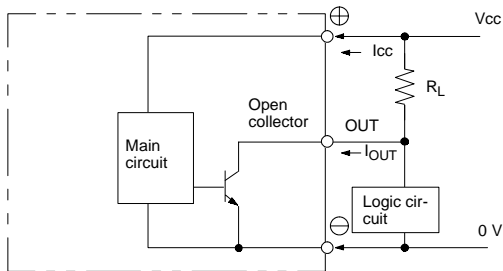

TIMING CHART

Light-ON



Dimensions

Unit: mm (inch)

EE-SX460-P1

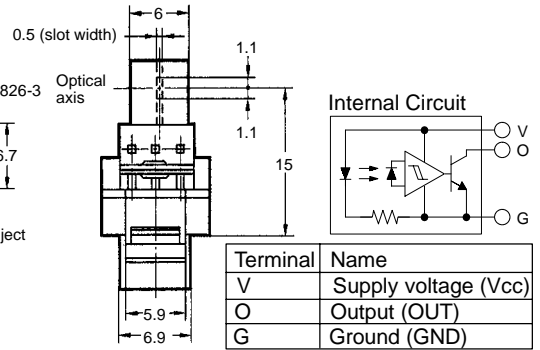
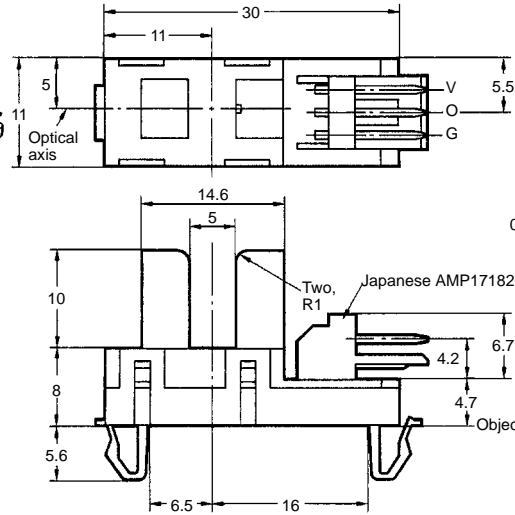
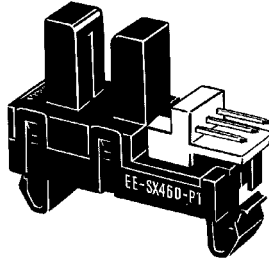

EE-1005 Connector

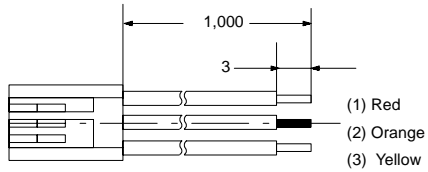

Contact AMP for availability of AMP mating connectors.

Mounting Holes

Note: Refer to the Technical Information section for snap-in mounting procedure.

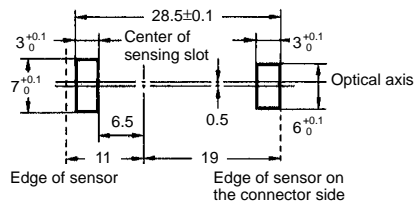

Precautions

Refer to the Technical Information Section for general precautions.

NOTE: DIMENSIONS SHOWN ARE IN MILLIMETERS. To convert millimeters to inches divide by 25.4.

OMRON[®]

OMRON ELECTRONICS, INC.

One East Commerce Drive
Schaumburg, IL 60173

1-800-55-OMRON

OMRON CANADA, INC.

885 Milner Avenue
Scarborough, Ontario M1B 5V8

416-286-6465