

TENTATIVE TOSHIBA HYBRID DIGITAL INTEGRATED CIRCUIT
8,388,608-WORD BY 64-BIT SYNCHRONOUS DRAM MODULE

DESCRIPTION

The THLY6480H1FG is a 8,388,608-word by 64-bit synchronous dynamic RAM module consisting of four TC59SM716FT/FTL DRAMs on a printed circuit board.

FEATURES

- 8,388,608-word by 64-bit organization
- Single power supply of 3.3 V ± 0.3 V
- Pipeline architecture
- Auto-Refresh and Self-Refresh capability
- All inputs and outputs LVTTTL-compatible
- 4096 Refresh cycles per 64 ms
- Package: 144-pin small-outline DIMM (gold contacts)
- -75,-75L: Based on PC133 SDRAM Unbuffered SO-DIMM Design Specification Rev.0.01
- -80,-80L: Based on Intel PC100 SOD Rev.1.0

	-75/-75L	-80/-80L
t _{CK} Clock Cycle Time (CL = 3)	7.5 ns	10 ns
t _{RAS} Active-to-Precharge Command Period (min)	45 ns	48 ns
t _{AC} Access Time from CLK (CL = 3)	5.4 ns	6 ns
t _{RC} Ref/Active-to-Ref/Active Command Period (min)	65 ns	68 ns

PIN ASSIGNMENT (TOP VIEW)

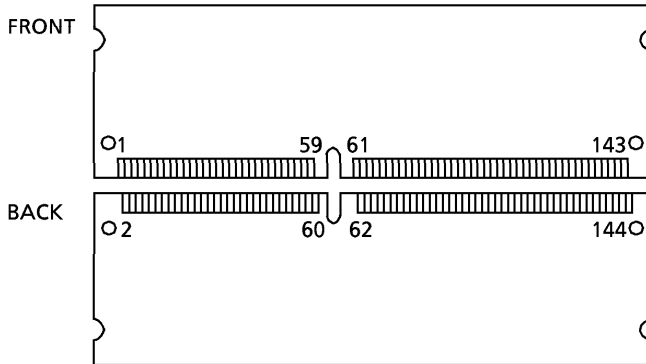

PIN NAMES

A0 ~ A11	Address Inputs
BA0, BA1	Bank Select
DQ0 ~ DQ63	Data Inputs/Outputs
/CS0	Chip Select
/RAS	Row Address Strobe
/CAS	Column Address Strobe
/WE	Write Enable
DQMB0 ~ DQMB7	Output Disable / Write Mask
CLK0	Clock Input
CKE	Clock Enable
SDA	Serial Data / Address for PD
SCL	Clock for PD
VDD	Power (+3.3 V)
VSS	Ground
NC	No Connection

1 VSS	2 VSS	49 DQ13	50 DQ45	97 DQ22	98 DQ54
3 DQ0	4 DQ32	51 DQ14	52 DQ46	99 DQ23	100 DQ55
5 DQ1	6 DQ33	53 DQ15	54 DQ47	101 VDD	102 VDD
7 DQ2	8 DQ34	55 VSS	56 VSS	103 A6	104 A7
9 DQ3	10 DQ35	57 NC	58 NC	105 A8	106 BA0
11 VDD	12 VDD	59 NC	60 NC	107 VSS	108 VSS
13 DQ4	14 DQ36	61 CLK0	62 CKE	109 A9	110 BA1
15 DQ5	16 DQ37	63 VDD	64 VDD	111 A10	112 A11
17 DQ6	18 DQ38	65 /RAS	66 /CAS	113 VDD	114 VDD
19 DQ7	20 DQ39	67 /WE	68 NC	115 DQMB2	116 DQMB6
21 VSS	22 VSS	69 /CS0	70 NC	117 DQMB3	118 DQMB7
23 DQMB0	24 DQMB4	71 NC	72 NC	119 VSS	120 VSS
25 DQMB1	26 DQMB5	73 NC	74 NC	121 DQ24	122 DQ56
27 VDD	28 VDD	75 VSS	76 VSS	123 DQ25	124 DQ57
29 A0	30 A3	77 NC	78 NC	125 DQ26	126 DQ58
31 A1	32 A4	79 NC	80 NC	127 DQ27	128 DQ59
33 A2	34 A5	81 VDD	82 VDD	129 VDD	130 VDD
35 VSS	36 VSS	83 DQ16	84 DQ48	131 DQ28	132 DQ60
37 DQ8	38 DQ40	85 DQ17	86 DQ49	133 DQ29	134 DQ61
39 DQ9	40 DQ41	87 DQ18	88 DQ50	135 DQ30	136 DQ62
41 DQ10	42 DQ42	89 DQ19	90 DQ51	137 DQ31	138 DQ63
43 DQ11	44 DQ43	91 VSS	92 VSS	139 VSS	140 VSS
45 VDD	46 VDD	93 DQ20	94 DQ52	141 SDA	142 SCL
47 DQ12	48 DQ44	95 DQ21	96 DQ53	143 VDD	144 VDD

000707EBA2

- TOSHIBA is continually working to improve the quality and reliability of its products. Nevertheless, semiconductor devices in general can malfunction or fail due to their inherent electrical sensitivity and vulnerability to physical stress. It is the responsibility of the buyer, when utilizing TOSHIBA products, to comply with the standards of safety in making a safe design for the entire system, and to avoid situations in which a malfunction or failure of such TOSHIBA products could cause loss of human life, bodily injury or damage to property. In developing your designs, please ensure that TOSHIBA products are used within specified operating ranges as set forth in the most recent TOSHIBA products specifications. Also, please keep in mind the precautions and conditions set forth in the "Handling Guide for Semiconductor Devices," or "TOSHIBA Semiconductor Reliability Handbook" etc..
- The TOSHIBA products listed in this document are intended for usage in general electronics applications (computer, personal equipment, office equipment, measuring equipment, industrial robotics, domestic appliances, etc.). These TOSHIBA products are neither intended nor warranted for usage in equipment that requires extraordinarily high quality and/or reliability or a malfunction or failure of which may cause loss of human life or bodily injury ("Unintended Usage"). Unintended Usage include atomic energy control instruments, airplane or spaceship instruments, transportation instruments, traffic signal instruments, combustion control instruments, medical instruments, all types of safety devices, etc.. Unintended Usage of TOSHIBA products listed in this document shall be made at the customer's own risk.
- The products described in this document are subject to the foreign exchange and foreign trade laws.
- The information contained herein is presented only as a guide for the applications of our products. No responsibility is assumed by TOSHIBA CORPORATION for any infringements of intellectual property or other rights of the third parties which may result from its use. No license is granted by implication or otherwise under any intellectual property or other rights of TOSHIBA CORPORATION or others.
- The information contained herein is subject to change without notice.

SERIAL PRESENCE DETECT

Byte Number	Function	-75 / -75L		-80 / -80L	
		Entry Value	Entry	Entry Value	Entry
0	Defines # of Bytes of information Written into Serial Memory by Module Manufacturer Group	128 bytes	80h	128 bytes	80h
1	Total # of Bytes in SPD Memory Device	256 bytes	08h	256 bytes	08h
2	Fundamental Memory Type (FPM, EDO, SDRAM...) from Appendix A	SDRAM	04h	SDRAM	04h
3	# of Row Addresses on this Assembly	RA0 ~ RA11	0Ch	RA0 ~ RA11	0Ch
4	# of Column Addresses on this Assembly	CA0 ~ CA8	09h	CA0 ~ CA8	09h
5	# of Module Banks on this Assembly	1 Bank	01h	1 Bank	01h
6	Data Width of this Assembly...	x64	40h	x64	40h
7	...Data Width Continuation	x64	00h	x64	00h
8	Voltage Interface Standard of this Assembly	LVTTTL	01h	LVTTTL	01h
9	SDRAM Cycle Time at Max. Supported CAS Latency (CL), @ CL = X	CL = 3, 7.5 ns	75h	CL = 3, 8.0 ns	80h
10	SDRAM Access from Clock @ CL = X	CL = 3, 5.4 ns	54h	CL = 3, 6.0 ns	60h
11	DIMM Configuration Type (Non-parity, Parity, ECC)	Non-Parity	00h	Non-Parity	00h
12	Refresh Rate/Type	15.625 μ s/ Self-Refresh	80h	15.625 μ s/ Self-Refresh	80h
13	SDRAM Width, Primary DRAM	x16	10h	x16	10h
14	Error Checking SDRAM Data Width	NA	00h	NA	00h
15	Minimum Clock Delay, Back-to-Back Random Column Addresses	1 CLK	01h	1 CLK	01h
16	Burst Lengths Supported	1, 2, 4, 8, Full page	8Fh	1, 2, 4, 8, Full page	8Fh
17	# of Banks on Each SDRAM Device	4 Banks	04h	4 Banks	04h
18	CAS # Latencies Supported	2, 3	06h	2, 3	06h
19	CS # Latency		01h		01h
20	WE # Latency		01h		01h
21	SDRAM Module Attributes	Unbuffered	00h		00h
22	SDRAM Device Attributes: General		0Eh		0Eh
23	Minimum Clock Cycle Time @ CL- X-1	CL = 2, 10 ns	A0h	CL = 2, 10 ns	A0h
24	Maximum Data Access Time from Clock @ CL X-1	CL = 2, 6.0 ns	60h	CL = 2, 6.0 ns	60h
25	Minimum Clock Cycle Time @ CL X-2		00h		00h
26	Maximum Data Access Time from Clock @ CL X-2		00h		00h
27	Minimum Row Precharge Time	20 ns	14h	20 ns	14h
28	Minimum Row-Active-to-Row-Active Delay	15 ns	0Fh	20 ns	14h
29	Minimum RAS-to-CAS Delay	20 ns	14h	20 ns	14h
30	Minimum RAS Pulse Width	45 ns	2Dh	48 ns	30h
31	Module/Bank Density	64 MB	10h	64 MB	10h
32	Command & Address Signal Input Setup Time	1.5 ns	15h	2 ns	20h
33	Command & Address Signal Input Hold Time	0.8 ns	08h	1 ns	10h
34	Data Signal Input Setup Time	1.5 ns	15h	2 ns	20h
35	Data Signal Input Hold Time	0.8 ns	08h	1 ns	10h
36-61	Superset Information (may be used in future)		00h		FFh
62	SPD Revision	Intel 1.2B	12h	Intel 1.2B	12h
63	Check sum for bytes 0 ~ 62	04A6h	A6h	1ED1h	D1h

OPTIONAL

64	Manufacturers JEDEC ID Code (JEP-106E)				
65-71					
72	Place of Manufacture				
73-90	Manufacturer's Part Number				
91-92	Revision Code				
93-94	Date of Manufacture				
95-98	Assembly Serial Number				
99-125	Manufacturer-Specific Data				
126	Reserved	Intel Specification	64h	Intel Specification	64h
127	Reserved		C7h		C7h
128-255					

BLOCK DIAGRAM

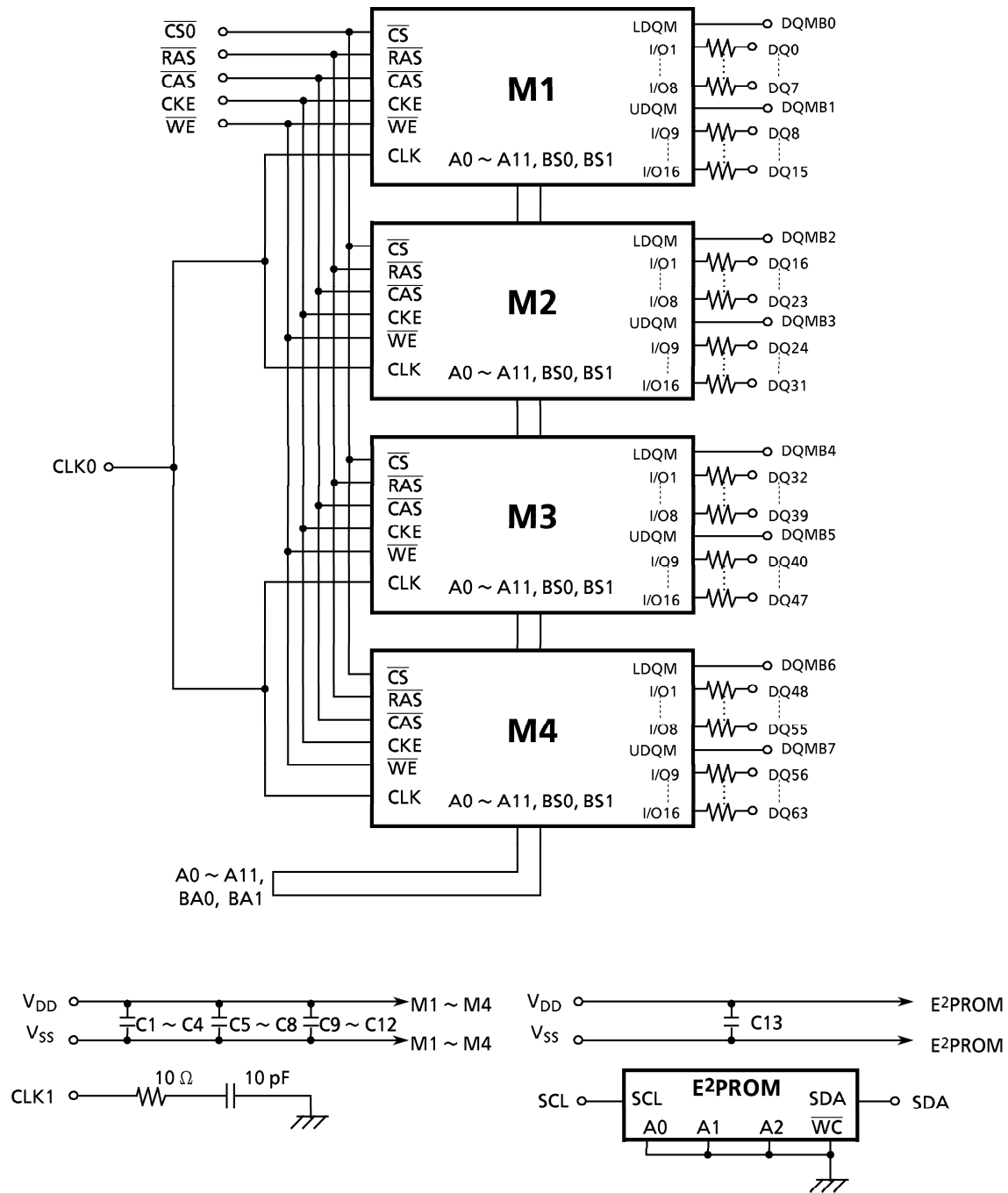

ABSOLUTE MAXIMUM RATINGS

SYMBOL	ITEM	RATING	UNIT	NOTES
V_{IN}	Input Voltage	$-0.3 \sim V_{DD} + 0.3$	V	1
V_{OUT}	Output Voltage	$-0.3 \sim V_{DD} + 0.3$	V	1
V_{DD}	Power Supply Voltage	$-0.3 \sim 4.6$	V	1
T_{OPR}	Operating Temperature	$0 \sim 70$	°C	1
T_{STG}	Storage Temperature	$-55 \sim 125$	°C	1
P_D	Power Dissipation	1.2	W	1
I_{OUT}	Short-Circuit Output Current	50	mA	1

RECOMMENDED DC OPERATING CONDITIONS ($T_a = 0^\circ \sim 70^\circ\text{C}$)

SYMBOL	PARAMETER	MIN	TYP.	MAX	UNIT	NOTES
V_{DD}	Supply Voltage	3.0	3.3	3.6	V	2
V_{IH}	LVTTTL Input High Voltage	2.0	-	$V_{DD} + 0.3$	V	2
V_{IL}	LVTTTL Input Low Voltage	-0.3	-	0.8	V	2

CAPACITANCE ($V_{DD} = 3.3\text{ V}$, $f = 1\text{ MHz}$, $T_a = 0^\circ \sim 70^\circ\text{C}$)

SYMBOL	PARAMETER	MIN	MAX	UNIT
C_{I1}	Input Capacitance (A0 ~ A11, BA0, BA1)	-	35	pF
C_{I2}	Input Capacitance (\overline{RAS} , \overline{CAS} , \overline{WE})	-	35	pF
C_{I3}	Input Capacitance (CLK0)	-	35	pF
C_{I4}	Input Capacitance ($\overline{CS0}$)	-	35	pF
C_{I5}	Input Capacitance (DQMB0 ~ DQMB7)	-	15	pF
C_{DQ}	I/O Capacitance (DQ0 ~ DQ63)	-	15	pF

DC CHARACTERISTICS ($V_{DD} = 3.3\text{ V} \pm 0.3\text{ V}$, $T_a = 0^\circ \sim 70^\circ\text{C}$)

SYMBOL	ITEM		-75 / -75L		-80 / -80L		UNIT	NOTES
			MIN	MAX	MIN	MAX		
I_{CC1}	OPERATING CURRENT Active-Precharge Command Cycling without Burst Operation ($t_{CK} = t_{RC} \text{ min}$)	1-Bank Operation	-	340	-	320	mA	3, 5
I_{CC2}	STANDBY CURRENT ($t_{CK} = \text{min}$, $\overline{CS} = V_{IH}$, $V_{IH/L} = V_{IH}(\text{min}) / V_{IL}(\text{max})$ Bank: Inactive State)	CKE = V_{IH}	-	180	-	90	mA	3
I_{CC2P}		CKE = V_{IL} (Power-Down Mode)	-	4	-	4		
I_{CC2S}	STANDBY CURRENT (CLK = V_{IL} , $\overline{CS} = V_{IH}$, $V_{IH/L} = V_{IH}(\text{min}) / V_{IL}(\text{max})$ Bank: Inactive State)	CKE = V_{IH}	-	40	-	40	mA	
I_{CC2PS}		CKE = V_{IL} (Power-Down Mode)	-	4	-	4		
I_{CC3}	NO OPERATING CURRENT ($t_{CK} = \text{min}$, $\overline{CS} = V_{IH}(\text{min})$ Bank: Active State (4 Banks))	CKE = V_{IH}	-	200	-	120	mA	3
I_{CC3P}		CKE = V_{IL} (Power-Down Mode)	-	40	-	30		
I_{CC4}	BURST OPERATING CURRENT ($t_{CK} = \text{min}$, $\overline{CS} = V_{IH}(\text{min})$ Read / Write Command Cycling)		-	460	-	360	mA	3, 4, 5
I_{CC5}	AUTO-REFRESH CURRENT ($t_{CK} = \text{min}$, Auto-Refresh Command Cycling)		-	760	-	720	mA	3, 5
I_{CC6}	SELF-REFRESH CURRENT (Self-Refresh Mode, CKE = 0.2 V)	THLY6480G1FG-75,-80	-	16	-	8	mA	3
		THLY6480G1FG-75L,-80L	-	3.2	-	3.2		
$I_{I(L)}$	INPUT LEAKAGE CURRENT ($0\text{ V} \leq V_{IN} \leq V_{DD}$, All Other Pins Not under Test = 0 V)		-5	5	-5	5	μA	
$I_{O(L)}$	OUTPUT LEAKAGE CURRENT (D_{OUT} Is Disabled, $0\text{ V} \leq V_{OUT} \leq V_{DD}$)		-5	5	-5	5	μA	
V_{OH}	OUTPUT LEVEL LVTTTL Output H-Level Voltage ($I_{OUT} = -2\text{ mA}$)		2.4	-	2.4	-	V	
V_{OL}	OUTPUT LEVEL LVTTTL Output L-Level Voltage ($I_{OUT} = 2\text{ mA}$)		-	0.4	-	0.4	V	

AC CHARACTERISTICS AND OPERATING CONDITIONS

($V_{DD} = 3.3\text{ V} \pm 0.3\text{ V}$, $T_a = 0^\circ \sim 70^\circ\text{C}$) (Notes 5, 6, 10)

SYMBOL	PARAMETER	-75 / -75L		-80 / -80L		UNIT	NOTES	
		MIN	MAX	MIN	MAX			
t _{RC}	Ref/Active-Ref/Active Command Period	65		68		ns	8	
t _{RAS}	Active- Precharge Command Period	45	100000	48	100000			
t _{RCD}	Active-Read/Write Command Delay Time	20		20				
t _{CCD}	Read/Write(a) -Read/Write(b) Command Period	1		1		cycles		
t _{RP}	Precharge-Active Command Period	20		20		ns		
t _{RRD}	Active(a)-Active(b) Command Period	15		20				
t _{WR}	Write Recovery Time	CL* = 2	10	10				
		CL* = 3	7.5	8				
t _{CK}	CLK Cycle Time	CL* = 2	10	1000	1000			
		CL* = 3	7.5	1000	8			1000
t _{CH}	CLK High-Level Width	2.5		3				9
t _{CL}	CLK Low-Level Width	2.5		3				
t _{AC}	Access Time from CLK	CL* = 2		6	6			
		CL* = 3		5.4	6			
t _{OH}	Output Data Hold Time	2.7		3				7
t _{HZ}	Output Data High-Impedance Time	2.7	7.5	3	8			
t _{LZ}	Output Data Low-Impedance Time	0		0				
t _{SB}	Power-Down Mode Entry Time	0	7.5	0	8			
t _T	Transition Time of CLK (Rise and Fall)	0.5	10	0.5	10			
t _{DS}	Data-In Set-up Time	1.5		2				
t _{DH}	Data-In Hold Time	0.8		1				
t _{AS}	Address Set-up Time	1.5		2				
t _{AH}	Address Hold Time	0.8		1				
t _{CKS}	CKE Set-up Time	1.5		2				
t _{CKH}	CKE Hold Time	0.8		1				
t _{CMS}	Command Set-up Time	1.5		2				
t _{CMH}	Command Hold Time	0.8		1				
t _{REF}	Refresh Time		64		64	ms		
t _{RSC}	Mode Register Set Cycle Time	16		16		ns	8	

* CL is $\overline{\text{CAS}}$ latency.

NOTES:

1. Conditions outside the limits listed under Absolute Maximum Ratings may cause permanent damage to the device.
2. All voltages are referenced to Vss.
3. These parameters depend on the cycle rate and their values are measured at the cycle rate obtained using the minimum values of t_{CK} and t_{RC}. Input signals are changed once during t_{CK}.
4. These parameters depend on the output loading. The specified values are obtained with the output open.

5. AC TEST CONDITIONS

Reference Level for Output Signals	1.4 V/1.4 V
Output Load	See the diagram for AC Test Load (B) below
Input Signal Levels	2.4 V/0.4 V
Transition Time (Rise and Fall) of Input Signals	2 ns
Reference Level of Input Signals	1.4 V

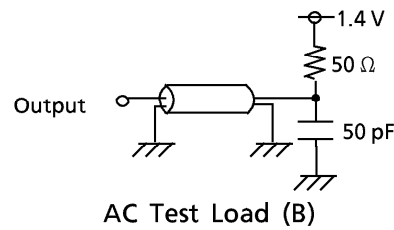
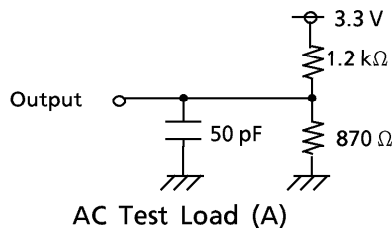

6. Transition times are measured between the V_{IH} and V_{IL} levels. The transition (rise and fall) of input signals has a fixed slope.
7. t_{HZ} defines the time at which the outputs go open-circuit and are not reference levels.
8. These parameters are specified for a given number of clock cycles and a given operating frequency. The relation-ship between the number of clock cycles, the timing value and the frequency (a clock period) is as follows:

$$\text{number of clock cycles} = \text{specified timing value} / \text{clock period}$$

(Fractions are rounded up to a whole number.)

9. t_{CH} is the pulse width of CLK measured from the positive edge to the negative edge and referenced to V_{IH} (min). t_{CL} is the pulse width of CLK measured from the negative edge to the positive edge and referenced to V_{IL} (max).
10. Power-up Sequence
Power-up must be performed in the following sequence.
- 1) Power must be applied to V_{DD} and V_{DDQ} (simultaneously) with all input signals held in the NOP state. The CLK signal must be started at the same time as power is applied.
 - 2) After power-up a pause of at least 200 μ seconds is required. Then, DQMB and CKE must be held High (at the V_{CC} level) to ensure that the DQ output is High-impedance.
 - 3) Both banks must be precharged.
 - 4) The Mode Register Set command must be asserted to initialize the Mode register.
 - 5) An Auto-Refresh operation, consisting of at least eight Auto-Refresh cycles, must be performed.
- The order in which 4) and 5) are performed is interchangeable.

TIMING DIAGRAMS

READ TIMING

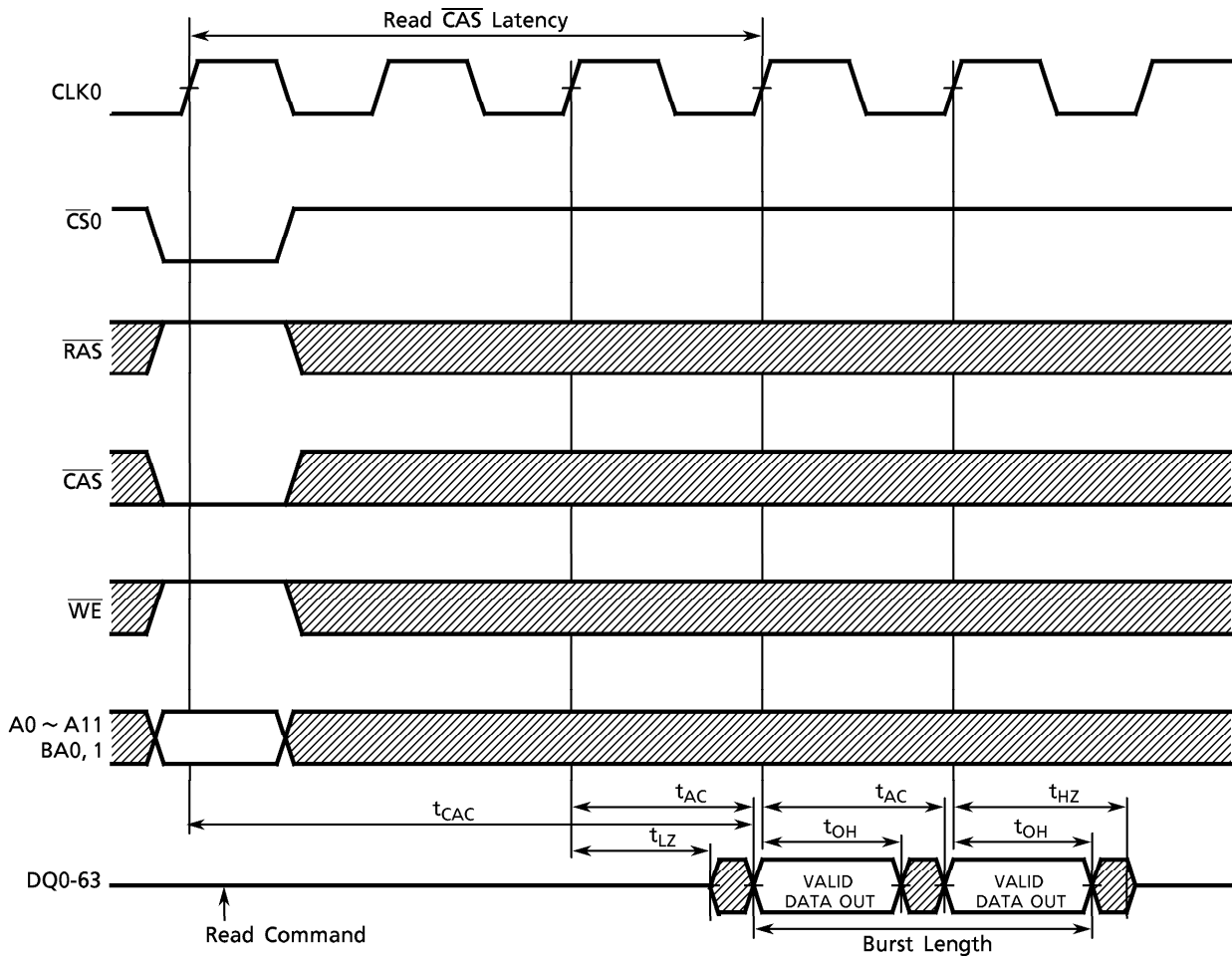

COMMAND INPUT TIMING

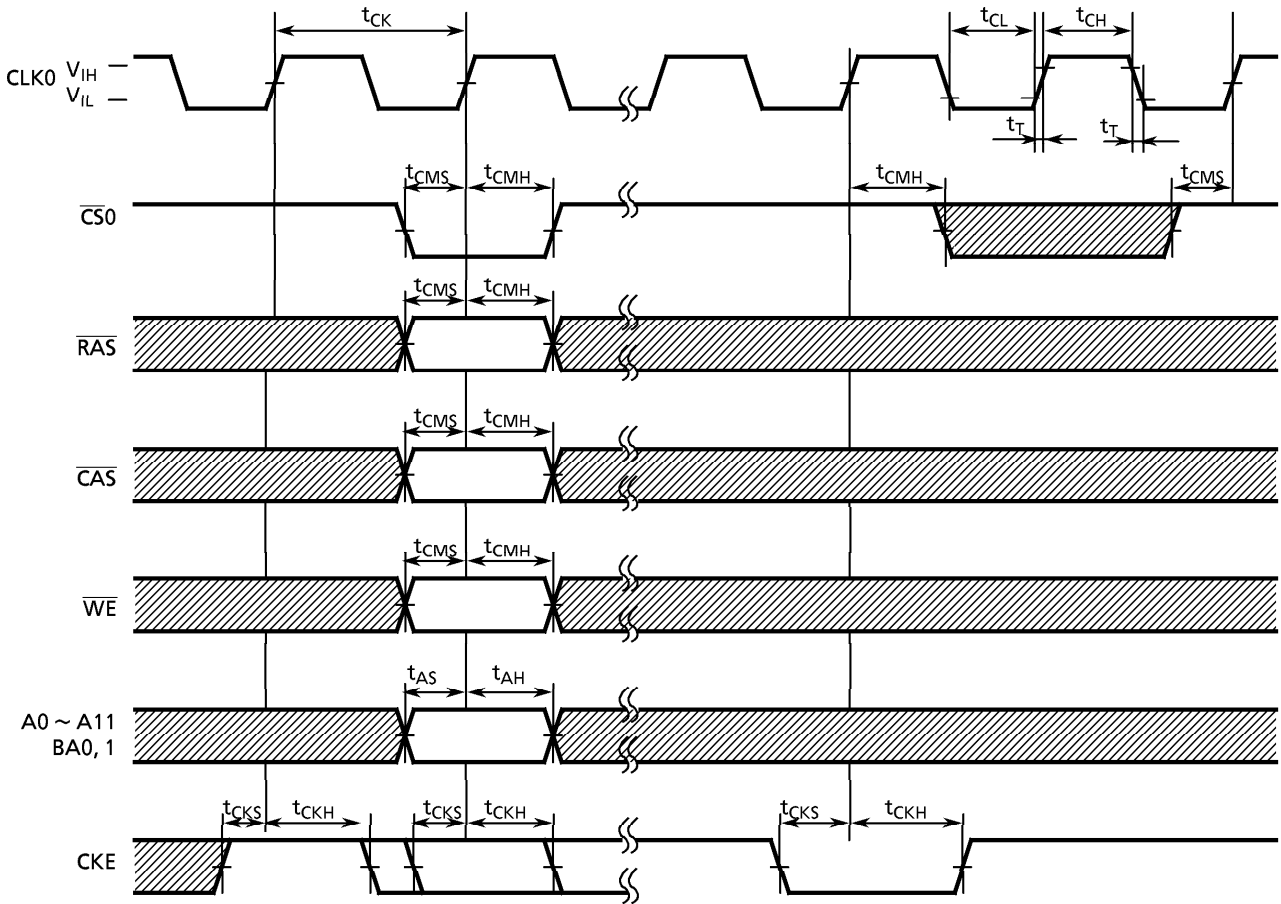

CONTROL TIMING FOR INPUT DATA

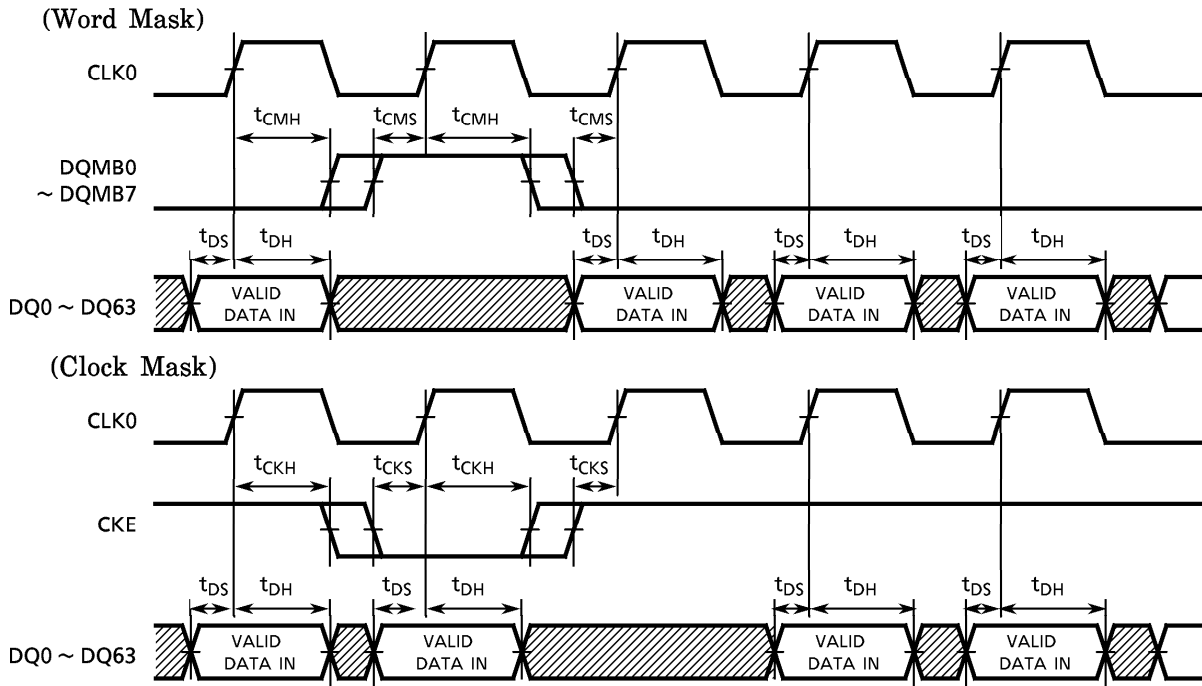

CONTROL TIMING FOR OUTPUT DATA

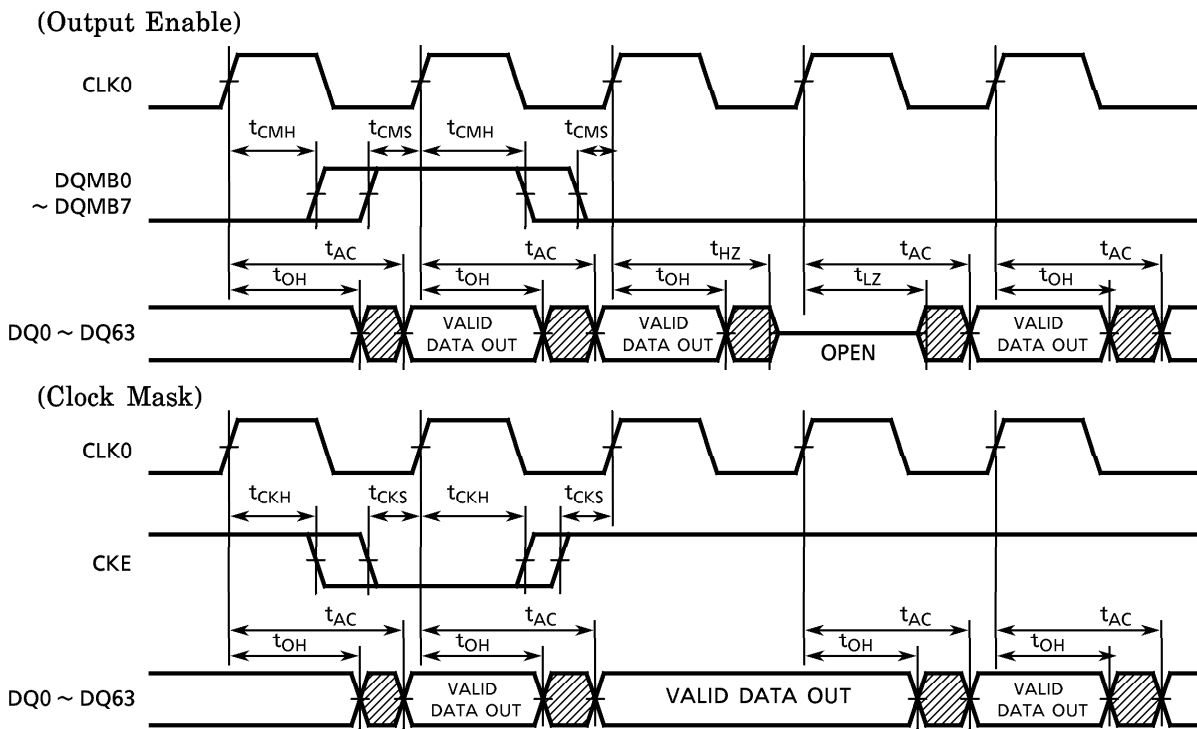

MODE REGISTER SET CYCLE

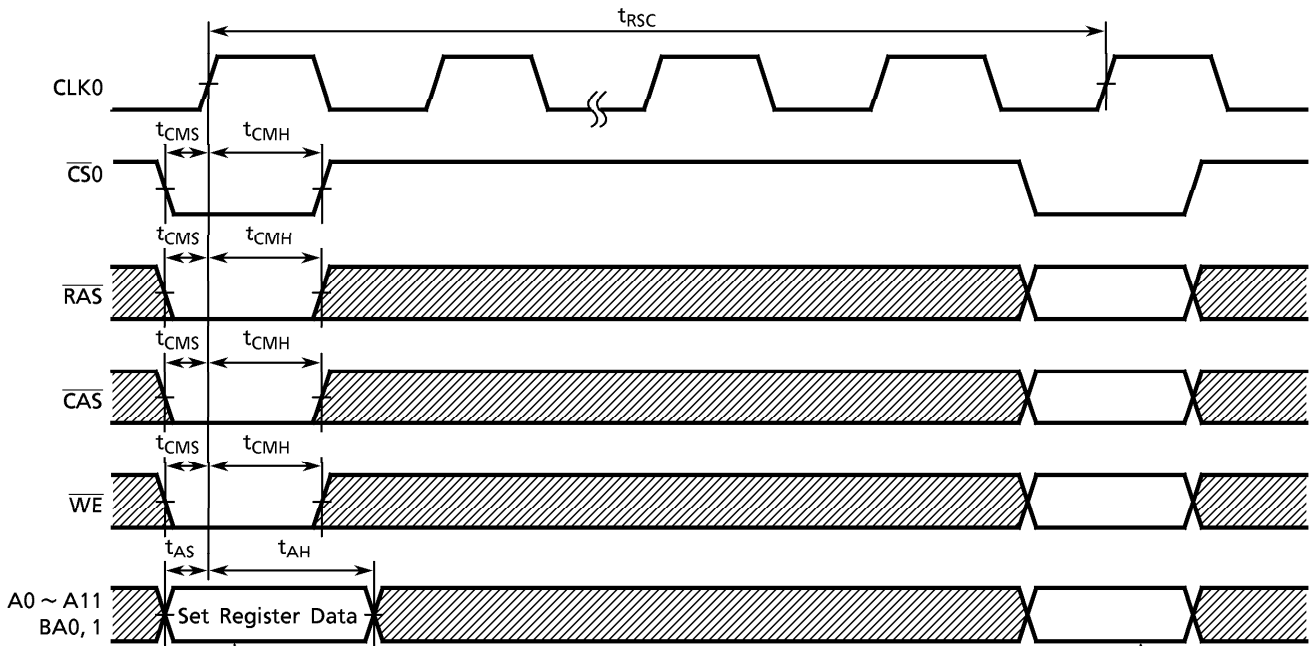

A0	Burst Length	
A1	Burst Length	
A2	Burst Length	
A3	Addressing Mode	
A4	CAS Latency	
A5	CAS Latency	
A6	CAS Latency	
A7	0	(Test Mode)
A8	0	Reserved
A9	Write Mode	
A10	0	Reserved
BA0	0	
BA1	0	

			Burst Length	
A2	A1	A0	Sequential	Interleaved
0	0	0	1	1
0	0	1	2	2
0	1	0	4	4
0	1	1	8	8
1	0	0	Reserved	Reserved
1	0	1		
1	1	0	Full Page	Full Page
1	1	1		

A3	Addressing Mode
0	Sequential
1	Interleaved

A6	A5	A4	CAS Latency
0	0	0	Reserved
0	0	1	Reserved
0	1	0	2
0	1	1	3
1	0	0	4

A9	Single Write Mode
0	Burst Read and Burst Write
1	Burst Read and Single Write

Next Command

PACKAGE DIMENSIONS (THLY6480H1FG)

Unit: mm

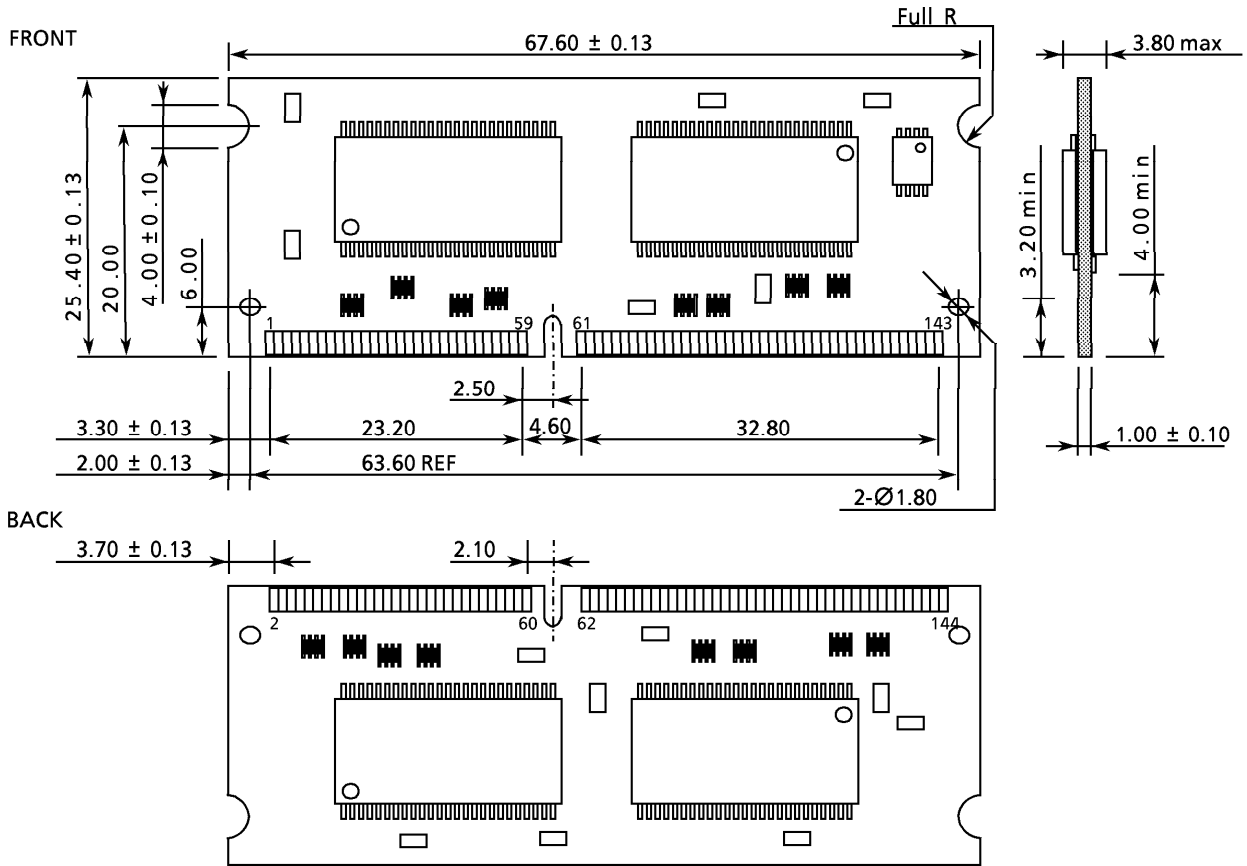

CONTACT DIMENSIONS ● THLY6480H1FG

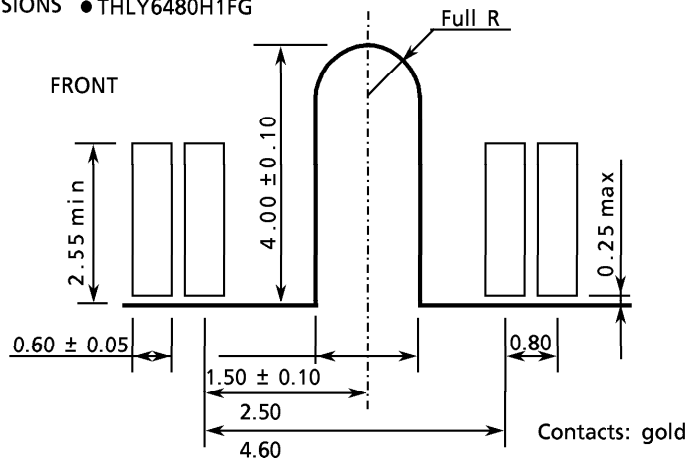

Weight: 6.2 g (typ.)