

■ Features

The thermopile sensor consists of a series of 116 thermoelements, forming a sensitive region size of $545\ \mu\text{m}$ (diameter). The sensor is hermetically sealed into a TO-5 metal housing, with an optical filter. This standard filter allows measurements to be made in the spectral range above $5\ \mu\text{m}$ wavelength. The thermosensor exhibits an almost white noise, comparable to an ohmic resistance. It has a constant signal versus frequency up to its frequency limit, and is directly proportional to incident radiation. The thermopile sensors are featured with an additional temperature reference resistor on the same chip. The standard version of temperature reference resistor is housing connected to ground.

■ Applications

- * Ear thermometers; clinic thermometers
- * Infrared thermometers
- * Consumer applications: hair dryer, micro-wave oven, air conditioner, refrigerator
- * Continuous temperature control of manufacturing
- * Security system
- * Radiation monitor switch system
- * Absorbing measurement for gas analysis
- * Thermoelectric converter
- * Heat flux flowmeter

■ Electrical Characteristics

Parameter	Condition	Min.	Typ.	Max.	Unit
Thermopile					
Number of thermojunctions		---	116	---	
Chip size		---	1740*1740	---	μm^2
Active region size	Interference layer	---	Diameter 545	---	μm
Thickness of substrate	Silicon-substrate	600	625	650	μm
Resistance of thermopile	25°C	50	65	80	K Ω
Sensitivity	With 5-14 μm filter	70	85	100	V/W
Detectivity		1.0×10^8	1.3×10^8	1.7×10^8	$\text{cm} \cdot \text{Hz}^{1/2} / \text{W}$
Time constant		---	16	---	ms
Noise voltage		28	32	36	nV/Hz ^{1/2}
NEP		0.28	0.36	0.48	nW/Hz ^{1/2}
Temperature range	Operation	-20	---	100	°C
Temperature reference resistor					
Resistance (1)	25°C	29.1	30.0	30.9	K Ω
Resistance (2)	25°C	97	100	103	K Ω
β value (1)	0°C/25°C	3773	3811	3849	K
β value (2)	0°C/25°C	3950	3970	3990	K

Measured at 1 Hz chopper frequency, within spectral range 5-14 μm , using a blackbody radiator of 500K temperature.

Note : Thermistor should be operated under 1mA.

■ Thermopile voltage vs. blackbody temperature

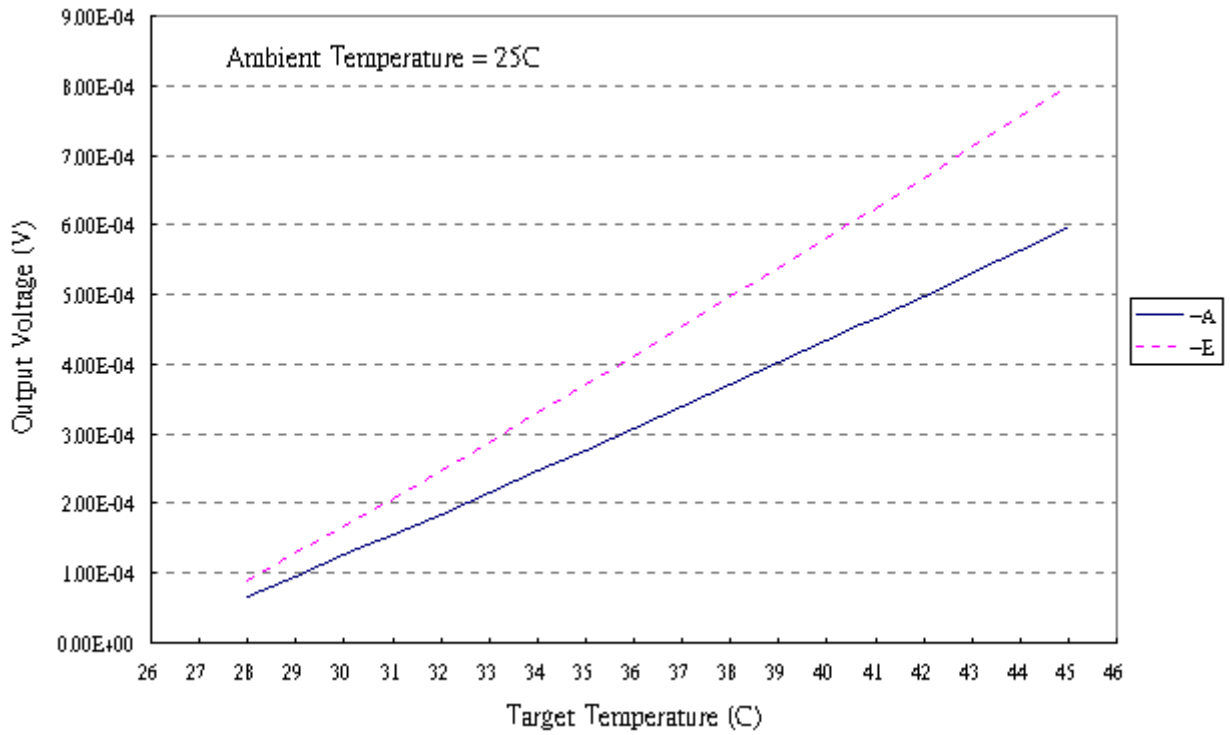

■ Frequency response

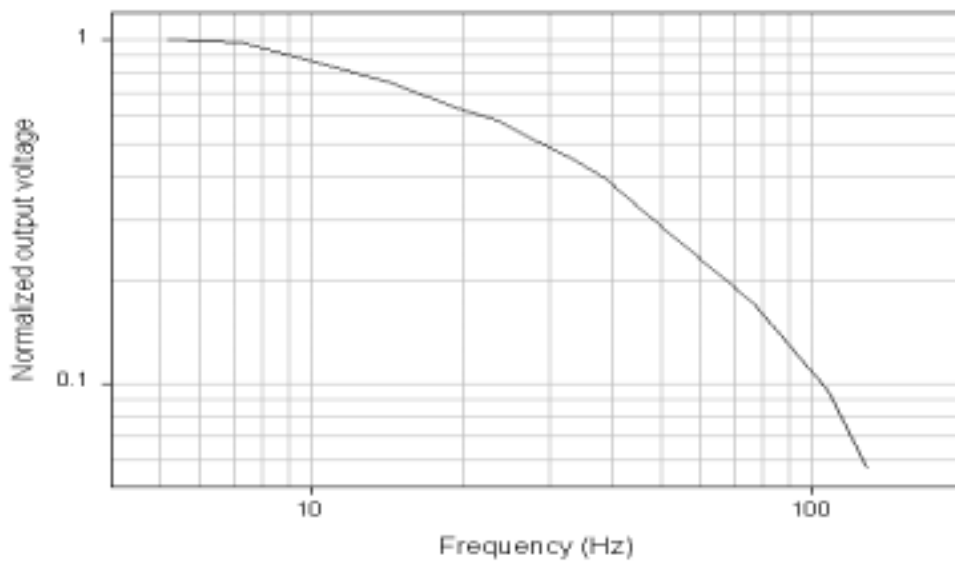

Field of view

1) window size: 2.57mm (diameter)

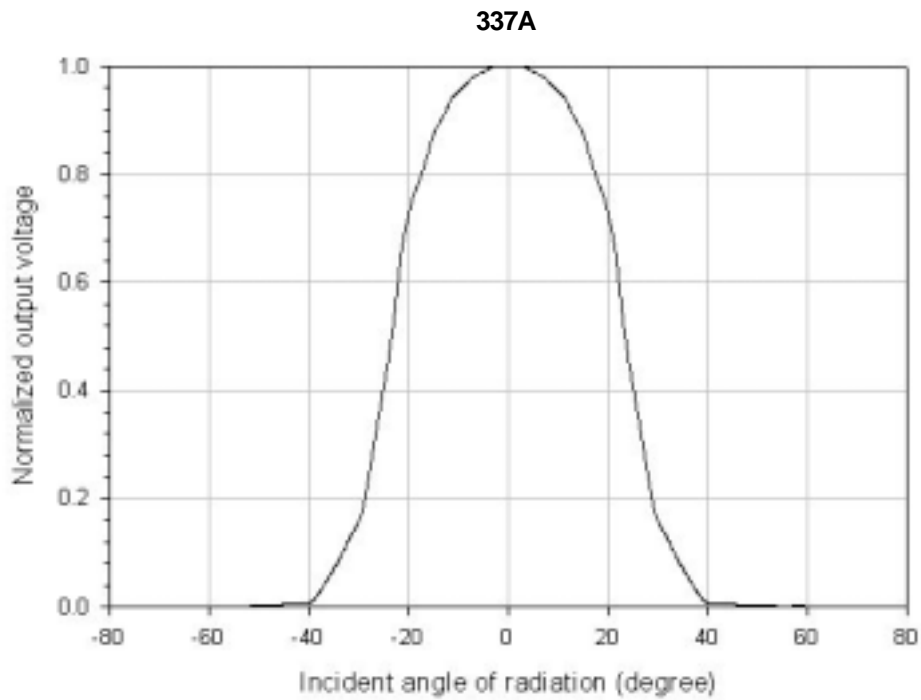

2) window size: 3.80mm (diameter)

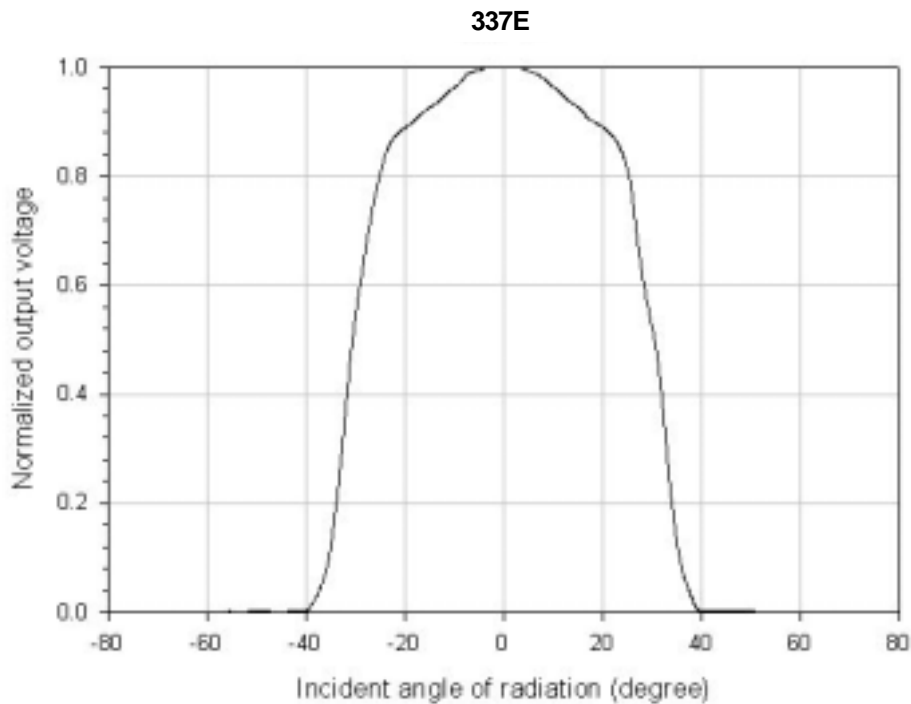

■ Thermistor vs. temperature

The resistance of the temperature reference resistor varies with temperature and the behaviour is illustrated in the following figure.

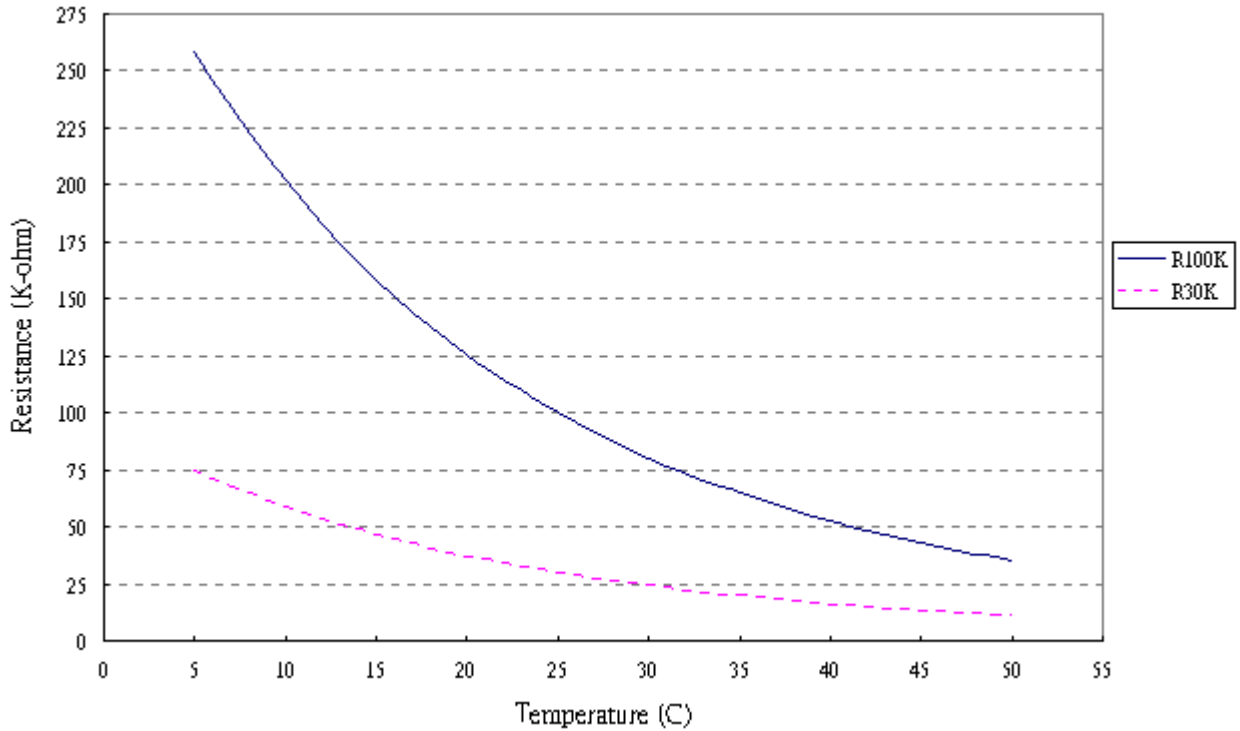

At temperature 25°C , $R(T)=R_{25}e^{\beta\left[\frac{1}{T}-\frac{1}{T_{25}}\right]}$ describes the resistance vs. temperature, where R_{25} is the resistance at ambient temperature 25°C and T, T_{25} are the ambient temperatures in unit of kelvin degrees.

■ Pin assignment & description

- 2 thermistor pin
- 4 thermistor pin (GND)
- 1 thermopile output pin (+)
- 3 thermopile output pin (-)

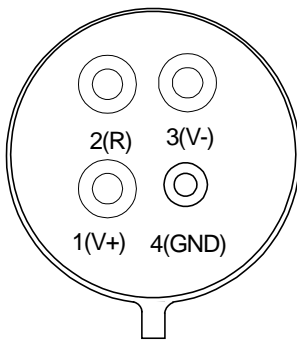

BACKSIDE VIEW

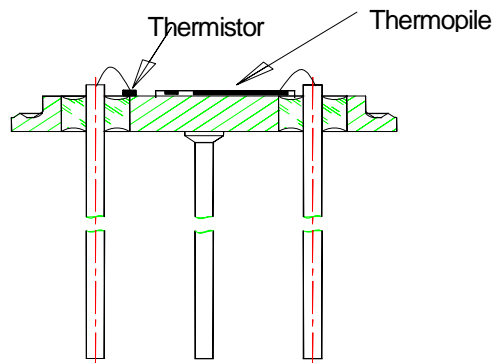

SIDE VIEW

■ Order information : TP337□

- : A : Standard filter (5-14 μ m), window size=2.57mm (diameter).
- B : Silicon filter with flat band transmission, window size=2.57mm (diameter).
- E : Standard filter (5-14 μ m), window size=3.80mm (diameter).
- F : Silicon filter with flat band transmission, window size=3.80mm (diameter).

■ Transmission of filter

Transmission of optical filter is measured by FTIR from 2 μm

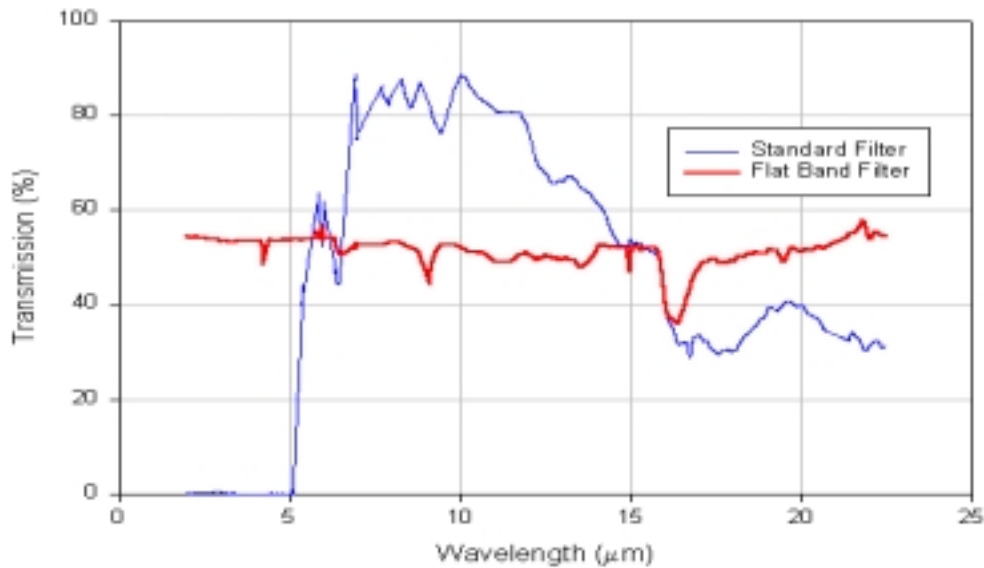

■ Package

The sensor is hermetically sealed into a TO-5 metal housing, with an optical filter. This standard filter allows measurements to be made in the spectral range above 5 μm wavelength. The dimensions of header and cap are shown below.



TP337A

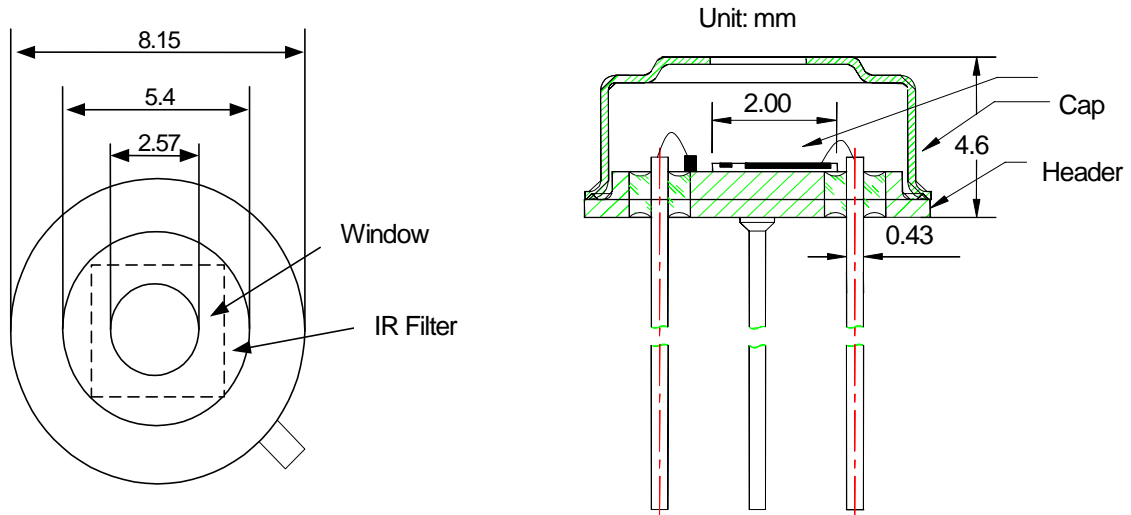

TP337E

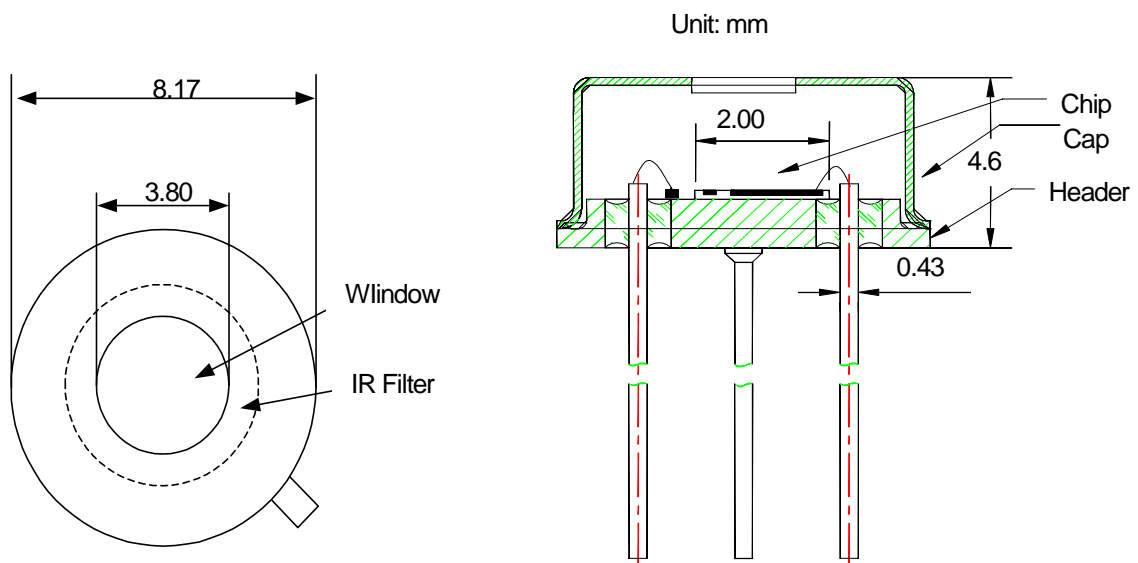

Application circuit

Circuit 1 :

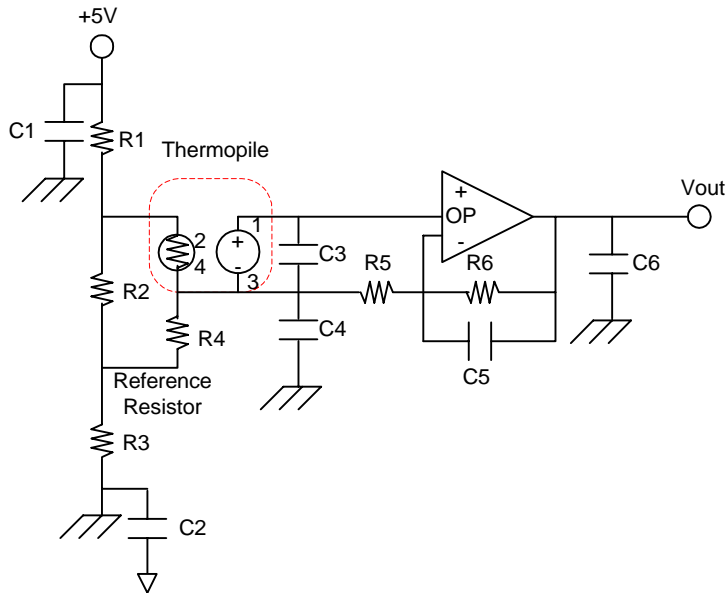

Circuit 2 :

