

# TIBPLS506AC 13 × 97 × 8 FIELD-PROGRAMMABLE LOGIC SEQUENCER

SRPS003C – D3090, DECEMBER 1987 – REVISED NOVEMBER 1995

- 58-MHz Max Clock Rate
- Two Transition Complement Array Terms
- 16-Bit Internal State Registers
- 8-Bit Output Registers
- Outputs Programmable for Registered or Combinational Operation
- Ideal for Waveform Generation and High-Performance State Machine Applications
- Programmable Output Enable
- Programmable Clock Polarity

## description

The TIBPLS506AC is a TTL field-programmable state machine of the Mealy type. This state machine (logic sequencer) contains 97 product terms (AND terms) and 48 sum terms (OR terms). The product and sum terms are used to control the 16-bit internal state registers and the 8-bit output registers.

The outputs of the internal state registers (P0–P15) are fed back and combined with the 13 inputs (I0–I12) to form the AND array. In addition, two sum terms are complemented and fed back to the AND array, which allows any product term to be summed, complemented, and used as input to the AND array.

The eight output cells can be individually programmed for registered or combinational operation. Nonregistered operation is selected by blowing the output multiplexer fuse. Registered output operation is selected by leaving the output multiplexer fuse intact.

Pin 17 can be programmed to function as an input and/or an output enable. Blowing the output enable fuse lets pin 17 function as an output enable but does not disconnect pin 17 from the input array. When the output enable fuse is intact, pin 17 functions only as an input with the outputs being permanently enabled.

The state and output registers are synchronously clocked by the fuse programmable clock input. The clock polarity fuse selects either positive- or negative-edge triggering. Negative-edge triggering is selected by blowing the clock polarity fuse. Leaving this fuse intact selects positive-edge triggering. After power-up, the device must be initialized to the desired state. When the output multiplexer fuse is left intact, registered operation is selected.

The TIBPLS506AC is characterized for operation from 0°C to 75°C.

JT OR NT PACKAGE  
(TOP VIEW)

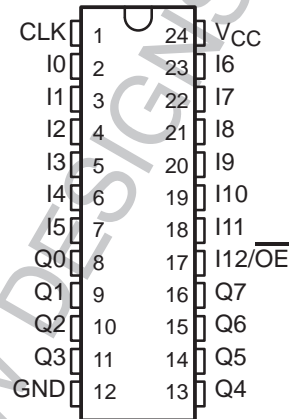

FK OR FN PACKAGE  
(TOP VIEW)

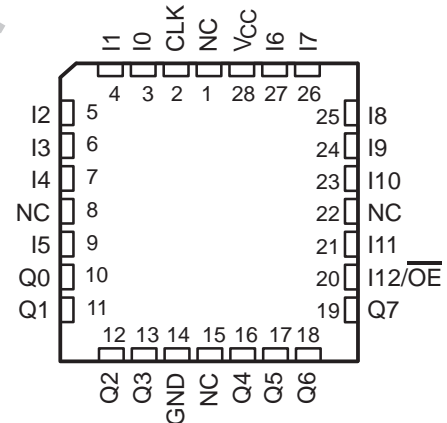

NC – No internal connection

**TIBPLS506AC**  
**13 × 97 × 8 FIELD-PROGRAMMABLE LOGIC SEQUENCER**

SRPS003C - D3090, DECEMBER 1987 - REVISED NOVEMBER 1995

logic diagram (positive logic)

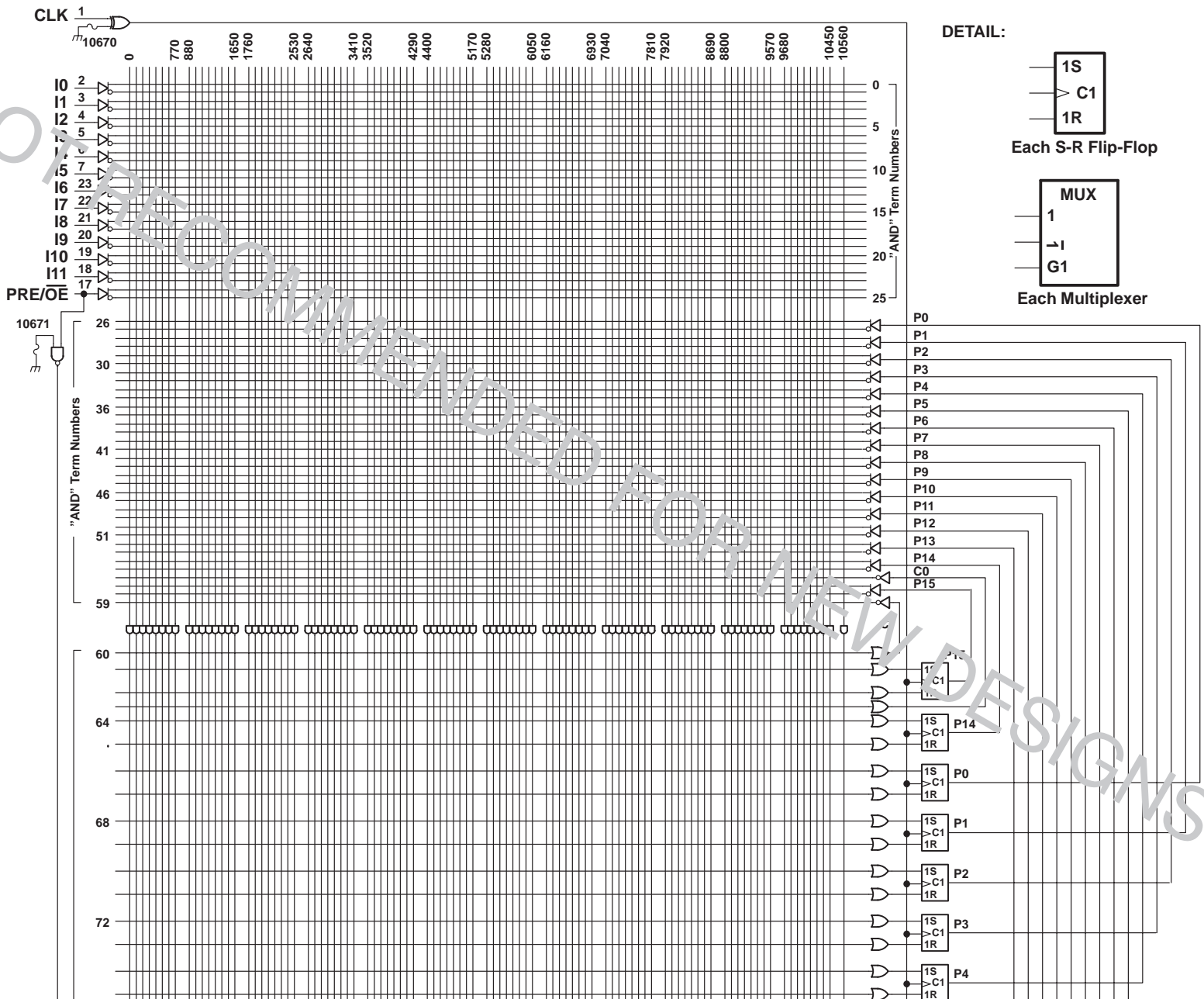

NOT RECOMMENDED FOR NEW DESIGNS

TIBPLS506AC  
 13 × 97 × 8 FIELD-PROGRAMMABLE LOGIC SEQUENCER

SRPS003C - D3090, DECEMBER 1987 - REVISED NOVEMBER 1995

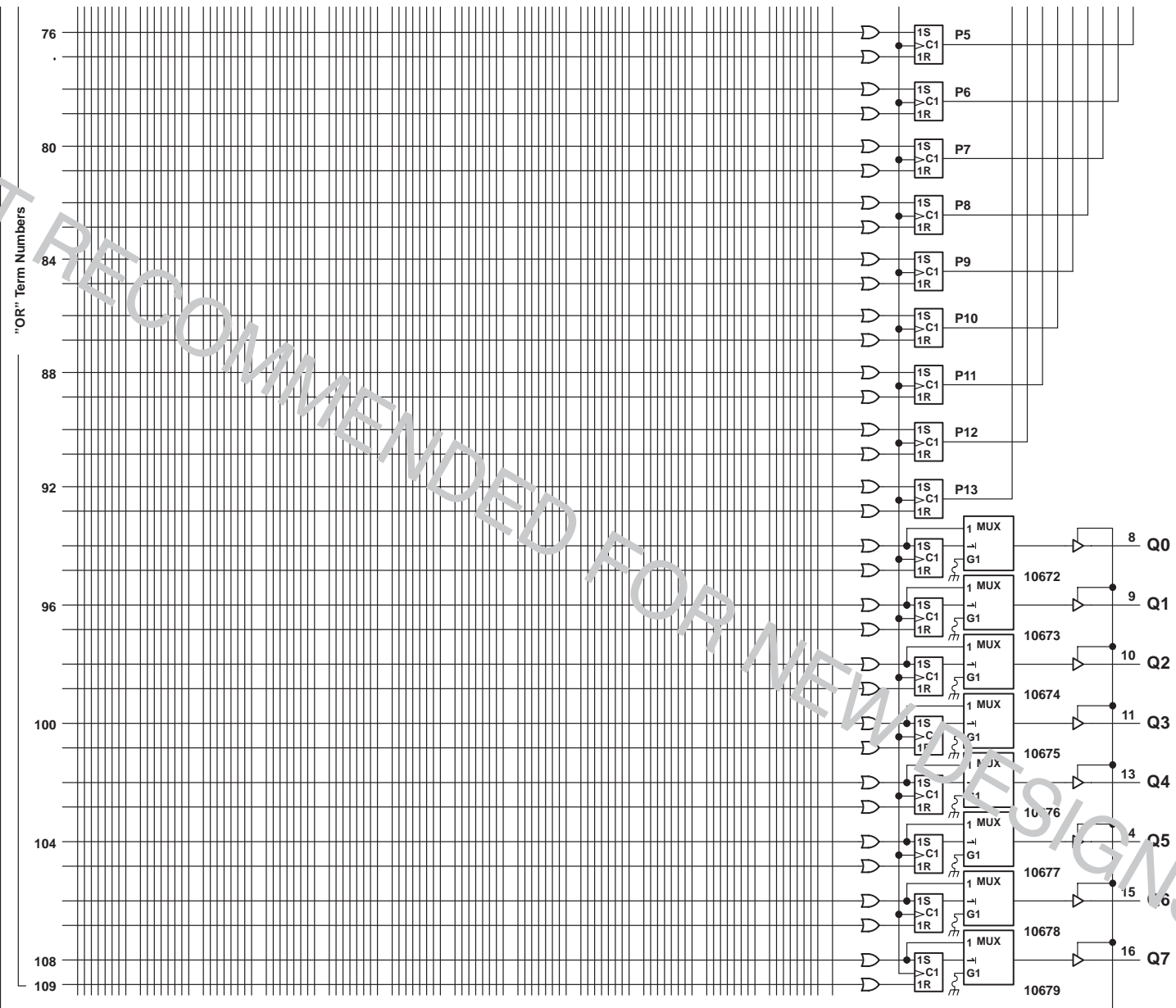

All inputs to AND gates, exclusive-OR gates, and multiplexers with a blown link assume the logic-1 state.  
 All OR gate inputs with a blown link assume the logic-0 state.

# TIBPLS506AC

## 13 × 97 × 8 FIELD-PROGRAMMABLE LOGIC SEQUENCER

SRPS003C – D3090, DECEMBER 1987 – REVISED NOVEMBER 1995

S-R FUNCTION TABLE (see Note 1)

| CLK POLARITY FUSE | CLK | S | R | STATE REGISTER |
|-------------------|-----|---|---|----------------|
| INTACT            | ↑   | L | L | Q <sub>0</sub> |
| INTACT            | ↑   | L | H | L              |
| INTACT            | ↑   | H | L | H              |
| INTACT            | ↑   | H | H | INDETERMINATE  |
| BLOWN             | ↓   | L | L | Q <sub>0</sub> |
| BLOWN             | ↓   | L | H | L              |
| BLOWN             | ↓   | H | L | H              |
| BLOWN             | ↓   | H | H | INDETERMINATE  |

NOTE 1: Q<sub>0</sub> is the state of the S-R registers before the active clock edge.

### functional block diagram (positive logic)

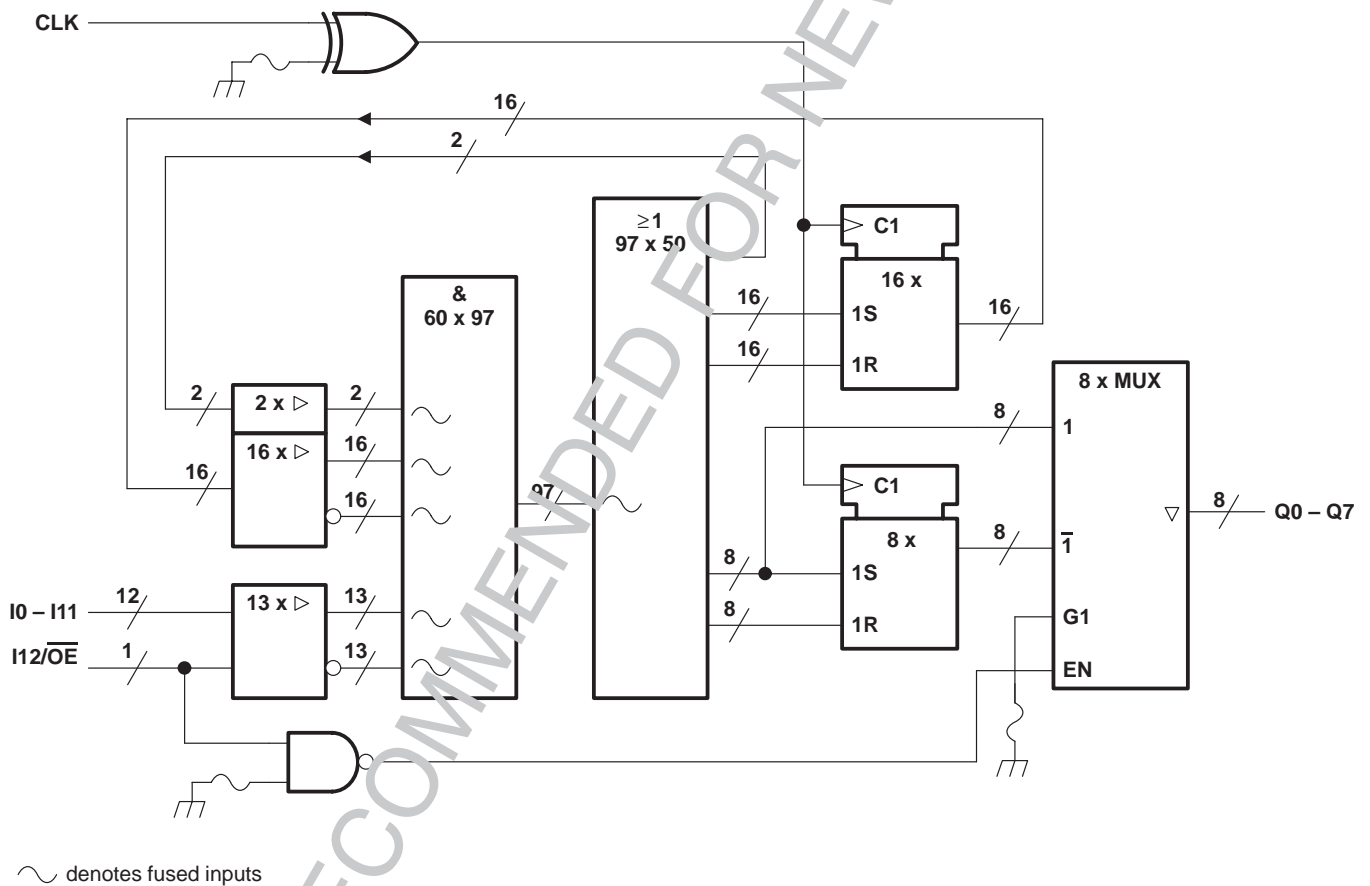

# TIBPLS506AC

## 13 × 97 × 8 FIELD-PROGRAMMABLE LOGIC SEQUENCER

SRPS003C – D3090, DECEMBER 1987 – REVISED NOVEMBER 1995

### absolute maximum ratings over operating free-air temperature range (unless otherwise noted)

|   |                |
|---|----------------|
| Supply voltage, $V_{CC}$ (see Note 2) .....           | 7 V            |
| Input voltage (see Note 2) .....                      | 5.5 V          |
| Voltage applied to disabled output (see Note 2) ..... | 5.5 V          |
| Operating free-air temperature range .....            | 0°C to 75°C    |
| Storage temperature range .....                       | –65°C to 150°C |

NOTE 2: These ratings apply except when programming pins during a programming cycle or during diagnostic testing.

### recommended operating conditions

|          |   | MIN                               | NOM             | MAX  | UNIT |
|----------|---|-----------------------------------|-----------------|------|------|
| $V_{CC}$ | Supply voltage                              | 4.75                              | 5               | 5.25 | V    |
| $V_{IH}$ | High-level input voltage, $V_{CC} = 5.25$ V | 2                                 |                 | 5.5  | V    |
| $V_{IL}$ | Low-level input voltage, $V_{CC} = 4.75$ V  |                                   |                 | 0.8  | V    |
| $I_{OH}$ | High-level output current                   |                                   |                 | –3.2 | mA   |
| $I_{OL}$ | Low-level output current                    |                                   |                 | 16   | mA   |
| $t_w$    | Pulse duration                              | Clock high                        | 6               |      | ns   |
|          |   | Clock low                         | 6               |      |      |
| $t_{su}$ | Setup time before CLK active transition†    | Input or feedback to S/R↑ inputs  | Without C-array | 12   | ns   |
|          |   | Input or feedback to S/R↓ inputs‡ |                 | 20   |      |
|          |   | Input or feedback to S/R inputs   | With C-array    | 25   |      |
| $t_h$    | Hold time after CLK                         | Input or feedback to S/R inputs   |                 | 0    | ns   |
| $T_A$    | Operating free-air temperature              | 0                                 | 25              | 75   | °C   |

† The active edge of CLK is determined by the programmed state of CLK polarity fuse.

‡ See the OR term loading section and Figure 3.

### electrical characteristics over recommended operating free-air temperature range (unless otherwise noted)

| PARAMETER       | TEST CONDITIONS    |                          | MIN | TYP§ | MAX   | UNIT |
|-----------------|--------------------|--------------------------|-----|------|-------|------|
| $V_{IK}$        | $V_{CC} = 4.75$ V, | $I_I = -18$ mA           |     |      | –1.2  | V    |
| $V_{OH}$        | $V_{CC} = 4.75$ V, | $I_{OL} = -3.2$ mA       | 2.4 | 3    |       | V    |
| $V_{OL}$        | $V_{CC} = 4.75$ V, | $I_{OL} = 16$ mA         |     | 0.37 | 0.5   | V    |
| $I_{OZH}$       | $V_{CC} = 5.25$ V, | $V_O = 2.7$ V            |     |      | 20    | μA   |
| $I_{OZL}$       | $V_{CC} = 5.25$ V, | $V_O = 0.4$ V            |     |      | –20   | μA   |
| $I_I$           | $V_{CC} = 5.25$ V, | $V_I = 5.5$ V            |     |      | 0.1   | mA   |
| $I_{IH}$        | $V_{CC} = 5.25$ V, | $V_I = 2.7$ V            |     |      | 20    | μA   |
| $I_{IL}$        | $V_{CC} = 5.25$ V, | $V_I = 0.4$ V            |     |      | –0.25 | mA   |
| $I_{O\ddagger}$ | $V_{CC} = 5.25$ V, | $V_O = 0.5$ V            | –30 |      | –130  | mA   |
| $I_{CC}$        | $V_{CC} = 5.25$ V, | See Note 3, Outputs open |     | 156  | 210   | mA   |
| $C_i$           | $f = 1$ MHz,       | $V_I = 2$ V              |     | 7    |       | pF   |
| $C_o$           | $f = 1$ MHz,       | $V_O = 2$ V              |     | 11   |       | pF   |
| $C_{clk}$       | $f = 1$ MHz,       | $V_{CLK} = 2$ V          |     | 14   |       | pF   |

§ All typical values are at  $V_{CC} = 5$  V,  $T_A = 25^\circ\text{C}$ .

‡ This parameter approximates  $I_{OS}$ . The condition  $V_O = 0.5$  V takes tester noise into account. Not more than one output should be shorted at a time and duration of the short circuit should not exceed one second.

NOTE 3: When the clock is programmed for negative edge, then  $V_I = 4.75$  V. When the clock is programmed for positive edge, then  $V_I = 0$ .



# TIBPLS506AC

## 13 × 97 × 8 FIELD-PROGRAMMABLE LOGIC SEQUENCER

SRPS003C – D3090, DECEMBER 1987 – REVISED NOVEMBER 1995

switching characteristics over recommended ranges of supply voltage and operating free-air temperature (unless otherwise noted)

| PARAMETER             | FROM (INPUT)                      | TO (OUTPUT)       | TEST CONDITION   | MIN  | TYP† | MAX | UNIT |
|-----------------------|-----------------------------------|-------------------|--|------|------|-----|------|
| $f_{\max}^{\ddagger}$ | Without C-array                   |                   | R1 = 300 $\Omega$ ,<br>R2 = 390 $\Omega$ ,<br>See Figure 5 | 58   | 65   |     | MHz  |
|                       | With C-array                      |                   |  | 33   | 45   |     |      |
|                       | External feedback without C-array |                   |  | 45   | 60   |     |      |
|                       | External feedback with C-array    |                   |  | 28.5 | 40   |     |      |
| $t_{pd}$              | CLK                               | Q (nonregistered) |  | 6    |      | 25  | ns   |
|                       |                                   | Q (registered)    |  | 3    |      | 10  |      |
|                       | I or Feedback                     | Q (nonregistered) |  | 6    |      | 20  |      |
| $t_{en}$              | $\overline{OE}\downarrow$         | Q                 |  | 1    | 6    | 10  | ns   |
| $t_{dis}$             | $\overline{OE}\uparrow$           | Q                 |  | 1    | 6    | 10  | ns   |

† All typical values are at  $V_{CC} = 5$  V,  $T_A = 25^\circ\text{C}$ .

‡ See the  $f_{\max}$  calculations section.

### $f_{\max}$ calculations

The following is a brief description of how the different operating frequencies can be achieved when using the TIBPLS506A.

$f_{\max}$  without C-(complementary) array =  $\frac{1}{t_{su} + t_{pd} \text{ CLK to Q}}$  where setup time  $t_{su}$  before CLK at the S/R

register inputs = 12 ns and propagation delay time  $t_{pd}$  CLK to Q for the internal S/R registers = 5 ns (difference in  $t_{pd}$  from CLK and feedback, 25 to 20).

Thus:  $f_{\max}$  for this condition =  $\frac{1}{(12 + 5) \text{ ns}} = \frac{1}{17 \text{ ns}} = 58 \text{ MHz}$ .

$f_{\max}$  with the C-array =  $\frac{1}{t_{su} + t_{pd} \text{ CLK to Q}}$  where  $t_{su}$  setup time before CLK at the S/R register

inputs = 25 ns and propagation delay time  $t_{pd}$  CLK to Q for the internal S/R registers = 5 ns (difference in  $t_{pd}$  from CLK and feedback, 25 to 20)

Thus:  $f_{\max}$  for this condition =  $\frac{1}{(25 + 5) \text{ ns}} = \frac{1}{30 \text{ ns}} = 33 \text{ MHz}$ .

$f_{\max}$  external feedback without the C-array =  $\frac{1}{t_{su} + t_{pd} \text{ CLK to Q}}$  where setup time  $t_{su}$  before CLK at the

S/R register inputs = 12 ns and propagation delay time  $t_{pd}$  CLK to Q for the internal S/R registers = 10 ns

Thus:  $f_{\max}$  for this condition =  $\frac{1}{(12 + 10) \text{ ns}} = \frac{1}{22 \text{ ns}} = 45 \text{ MHz}$ .

$f_{\max}$  external feedback with the C-array =  $\frac{1}{t_{su} + t_{pd} \text{ CLK to Q}}$  where setup time  $t_{su}$  before CLK at the S/R

register inputs = 25 ns and propagation delay time  $t_{pd}$  CLK to Q for the internal S/R registers = 10 ns.

Thus:  $f_{\max}$  for this condition =  $\frac{1}{(25 + 10) \text{ ns}} = \frac{1}{35 \text{ ns}} = 28.5 \text{ MHz}$ .

NOT RECOMMENDED FOR NEW DESIGNS



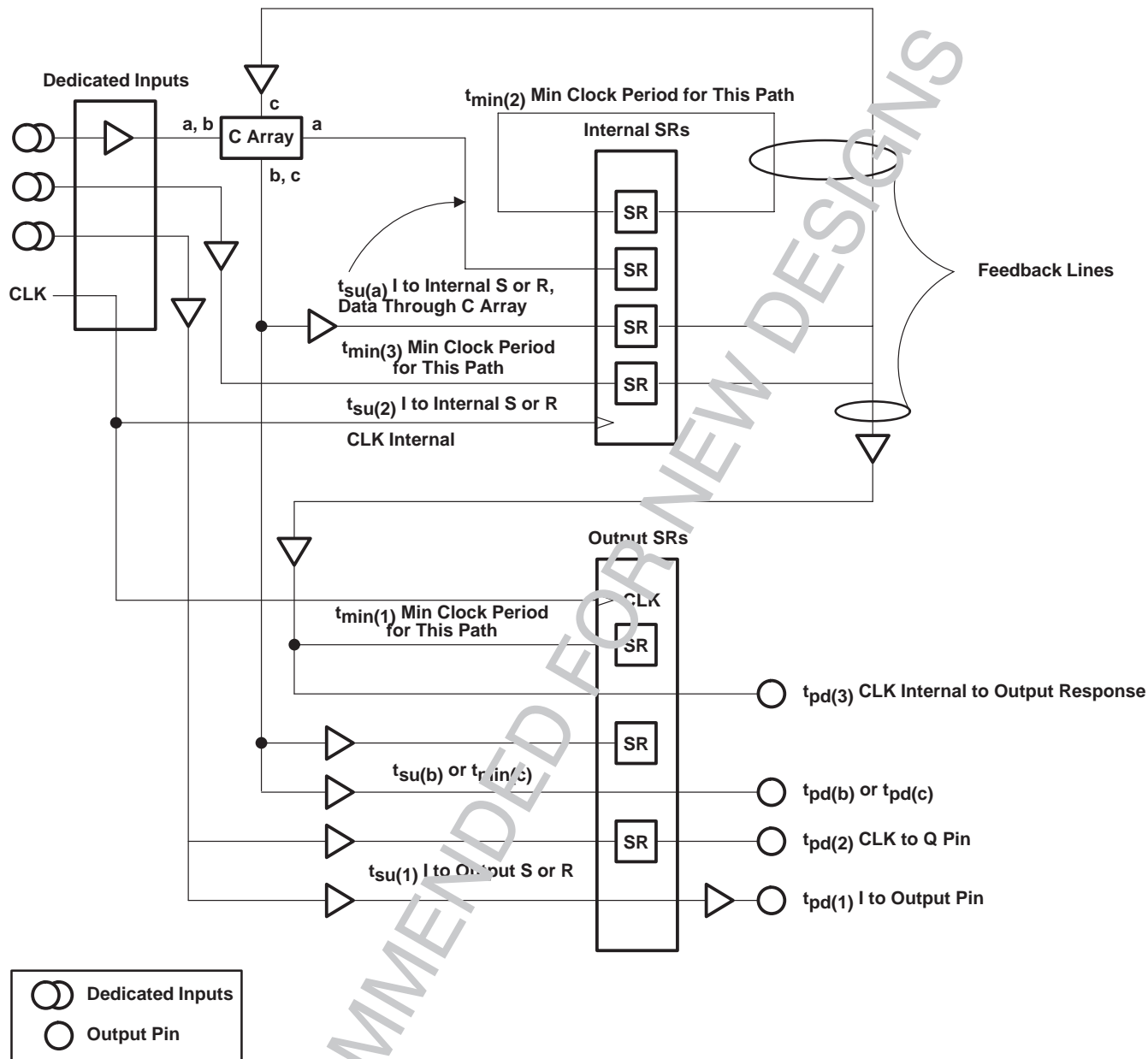

Figure 1. Timing Model

# TIBPLS506AC

## 13 × 97 × 8 FIELD-PROGRAMMABLE LOGIC SEQUENCER

SRPS003C – D3090, DECEMBER 1987 – REVISED NOVEMBER 1995

### glossary — timing model

- $t_{pd(1)}$  — Maximum time interval from the time a signal edge is received at any input pin to the time any logically affected combinational output pin delivers a response.
- $t_{pd(2)}$  — Maximum time interval from a positive edge on the clock input pin to data delivery on the output pin corresponding to any output SR register.
- $t_{pd(3)}$  — Maximum time interval from the positive edge on the clock input pin to the response on any logically affected combinational configured output (at the pin), where data origin is any internal SR register.
- $t_{pd(b)}$  — Maximum time interval from the time a signal edge is received at any input pin to the time any logically affected combinational output pin delivers a response, where data passes through a C-array once before reaching the affected output.
- $t_{pd(c)}$  — Maximum time interval from the positive edge on the clock input pin to the response on any logically affected combinational configured output (at the pin), where data origin is any internal SR register and data passes once through a C-array before reaching an affected output.
- $t_{su(1)}$  — Minimum time interval that must be allowed between the data edge on any dedicated input and the active clock edge on the clock input pin when data affects the S or R line of any output SR register.
- $t_{su(2)}$  — Minimum time interval that must be allowed between the data edge on any dedicated input and the active clock edge on the clock input pin when data affects the S or R line of any internal SR register.
- $t_{su(a)}$  — Minimum time interval that must be allowed between the data edge on any dedicated input and the active clock edge on the clock input pin when data passes once through a C-array before reaching an affected S or R line on any internal SR register.
- $t_{su(b)}$  — Minimum time interval that must be allowed between the data edge on any dedicated input and the active clock edge on the clock input pin when data passes once through a C-array before reaching an affected S or R line on any output SR register.
- $t_{min(1)}$  — Minimum clock period (or 1/[maximum frequency]) that the device will accommodate when using feedback from any internal SR register or counter bit to feed the S or R line of any output SR register.
- $t_{min(2)}$  — Minimum clock period (or 1/[maximum frequency]) that the device will accommodate when using feedback from any internal SR register to feed the S or R line of any internal SR register.
- $t_{min(3)}$  — Minimum clock period (or 1/[maximum frequency]) that the device will accommodate when using feedback from any internal SR register to feed the S or R line of any internal SR register and data passes once through a C-array before reaching an affected S or R line on any internal SR register.
- $t_{min(c)}$  — Minimum clock period (or 1/[maximum frequency]) that the device will accommodate when using feedback from any internal SR register to feed the S or R line of any output SR register and data passes once through a C-array before reaching an affected S or R line on any output SR register.

NOT RECOMMENDED FOR NEW DESIGNS



**PARAMETER VALUES FOR TIMING MODEL**

|                             |                                     |                              |
|-----------------------------|-------------------------------------|------------------------------|
| $t_{pd(1)} = 20 \text{ ns}$ | $t_{su(1)} = 12 \text{ ns}^\dagger$ | $t_{min(1)} = 20 \text{ ns}$ |
| $t_{pd(2)} = 10 \text{ ns}$ | $t_{su(2)} = 12 \text{ ns}^\dagger$ | $t_{min(2)} = 20 \text{ ns}$ |
| $t_{pd(3)} = 25 \text{ ns}$ | $t_{su(a)} = 25 \text{ ns}$         | $t_{min(3)} = 25 \text{ ns}$ |
|                             | $t_{su(b)} = 25 \text{ ns}$         | $t_{min(c)} = 25 \text{ ns}$ |

**INTERNAL NODE NUMBERS**

|       |             |        |             |
|-------|-------------|--------|-------------|
| Q0-Q7 | RESET 25-32 | P0-P15 | SET 33-48   |
| C0    | 65          |        | RESET 49-64 |
| C1    | 66          |        |             |

$^\dagger$  Use  $t_{su} = 20 \text{ ns}$  for applications where the setup time for S/R $\downarrow$  inputs are required.

**diagnostics**

A diagnostic mode is provided with these devices that allows the user to inspect the contents of the state registers. The step-by-step procedures required to use the diagnostics follow.

- Step 1. Disable all outputs by taking pin 17 ( $\overline{OE}$ ) high (see Note 4).
- Step 2. Take pin 8 (Q0) to  $V_{IH}$  to enable the diagnostics test sequence.
- Step 3. Apply appropriate levels of voltage to pins 11 (Q3), 13 (Q4), and 14 (Q5) to select the desired state register (see Table 1).

The voltage level monitored on pin 9 will indicate the state of the selected state register.

NOTE 4: If pin 17 is being used as an input to the array, then pin 7 ( $I_5$ ) must be taken to  $V_{IH}$  before pin 17 is taken high.

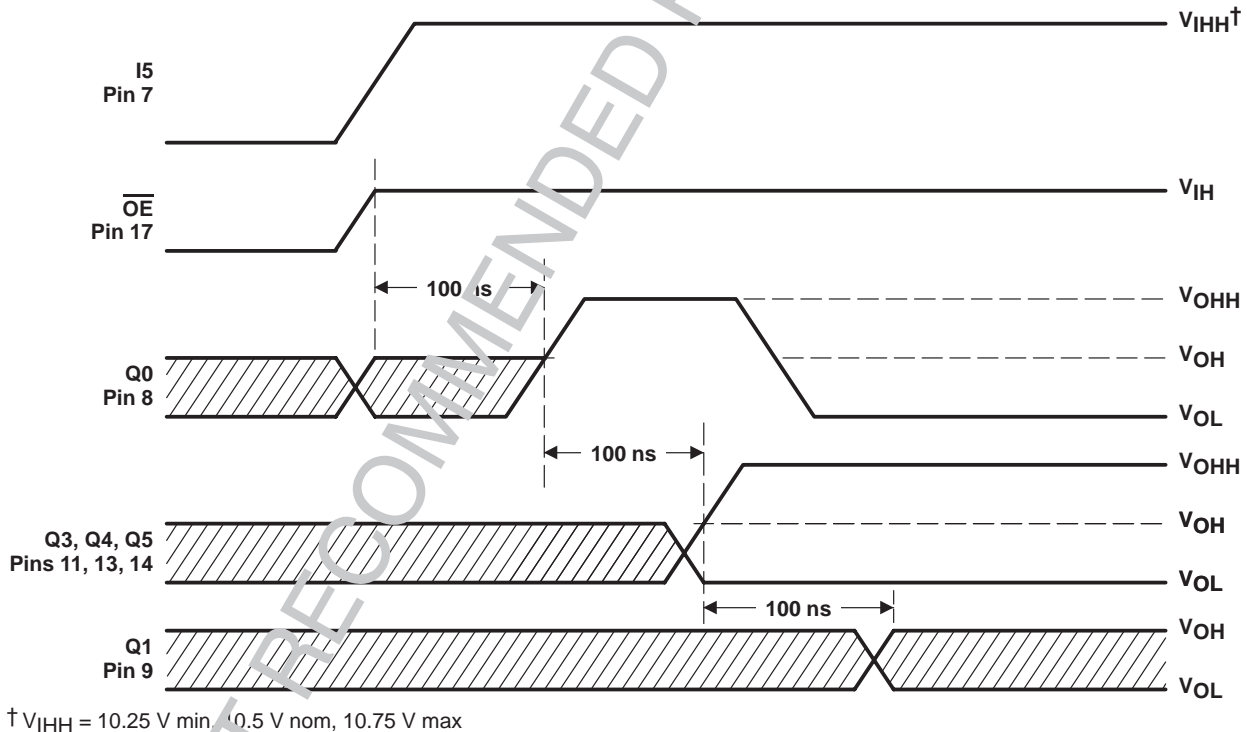

$^\dagger V_{IHH} = 10.25 \text{ V min}, 10.5 \text{ V nom}, 10.75 \text{ V max}$

**Figure 2. Diagnostics Waveforms**

**TIBPLS506AC**  
**13 × 97 × 8 FIELD-PROGRAMMABLE LOGIC SEQUENCER**

SRPS003C – D3090, DECEMBER 1987 – REVISED NOVEMBER 1995

**Table 1. Addressing State Registers During Diagnostics†**

| REGISTER BINARY ADDRESS |       |        | BURIED REGISTER |
|-------------------------|-------|--------|-----------------|
| PIN 11                  | PIN13 | PIN 14 | SELECTED        |
| L                       | L     | L      | C1              |
| L                       | L     | H      | P15             |
| L                       | L     | HH     | C0              |
| L                       | H     | L      | P14             |
| L                       | H     | H      | P0              |
| L                       | H     | HH     | P1              |
| L                       | HH    | L      | P2              |
| L                       | HH    | H      | P3              |
| L                       | HH    | HH     | P4              |
| H                       | L     | L      | P5              |
| H                       | L     | H      | P6              |
| H                       | L     | HH     | P7              |
| H                       | H     | L      | P8              |
| H                       | H     | H      | P9              |
| H                       | H     | HH     | P10             |
| H                       | HH    | L      | P11             |
| H                       | HH    | H      | P12             |
| H                       | HH    | HH     | P13             |

†  $V_{IHH} = 10.25 \text{ V min, } 10.5 \text{ V nom, } 10.75 \text{ V max}$

**programming information**

Texas Instruments programmable logic devices can be programmed using widely available software and inexpensive device programmers.

Complete programming specifications, algorithms, and the latest information on hardware, software, and firmware are available upon request. Information on programmers that are capable of programming Texas Instruments programmable logic is also available, upon request, from the nearest TI sales office, local authorized TI distributor, or by calling Texas Instruments at (214) 997-5666.

NOT RECOMMENDED FOR NEW DESIGNS



**OR term loading**

As shown in Figure 3 and by the  $f_{max}$  calculations,  $f_{max}$  is affected by the number of terms connected to each OR array line. Theoretically,  $f_{max}$  is calculated as:

$$f_{max} = \frac{1}{t_{su} + t_{pd}} \text{ CLK to Q}$$

Since the setup time (input or feedback to S/R↓) varies with the number of terms connected to each OR array line, (due to capacitance loading)  $f_{max}$  will also vary. Figure 3 illustrates the relationship between the number of terms connected per OR line and the setup time.

Use Figure 3 to determine the worst-case setup time for a particular application. Identify the OR array line with the maximum number of terms connected. Count the number of terms and use the graph to determine the setup time.

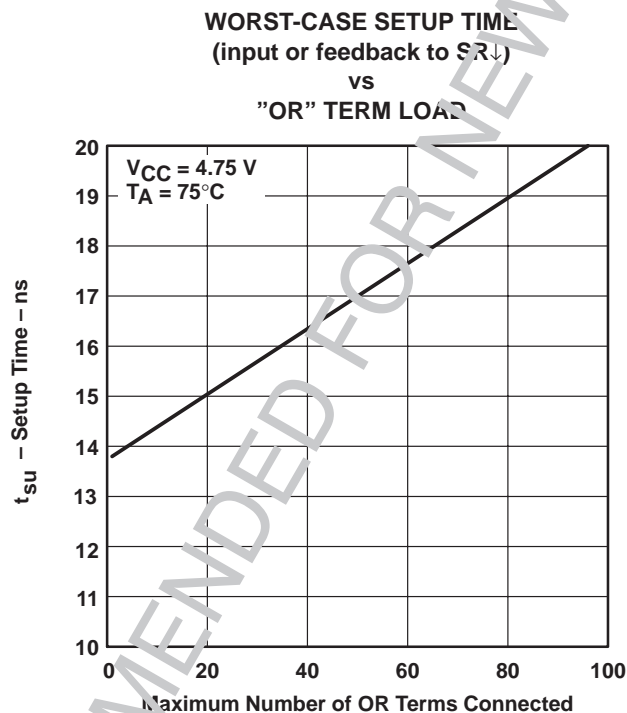

NOT RECOMMENDED FOR NEW DESIGNS

# TIBPLS506AC

## 13 × 97 × 8 FIELD-PROGRAMMABLE LOGIC SEQUENCER

SRPS003C – D3090, DECEMBER 1987 – REVISED NOVEMBER 1995

### $f_{\max}$ with external feedback

The configuration shown is a typical state-machine design with feedback signals sent off-chip. This external feedback could go back to the device inputs or to a second device in a multi-chip state machine. The slowest path defining the clock period is the sum of the clock-to-output delay time and the setup time for the input or feedback signals ( $t_{su} + t_{pd}$  CLK to Q).

$$\text{Thus: } f_{\max} \text{ with external feedback} = \frac{1}{t_{su} + t_{pd} \text{ CLK to Q}}$$

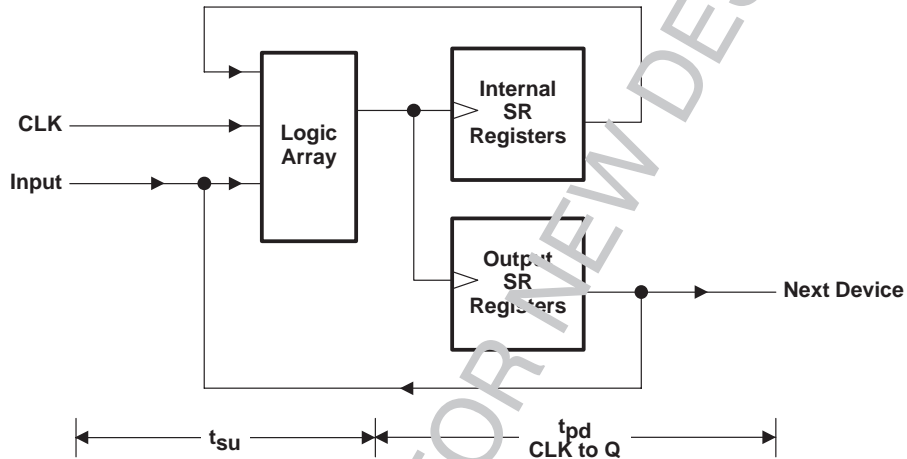
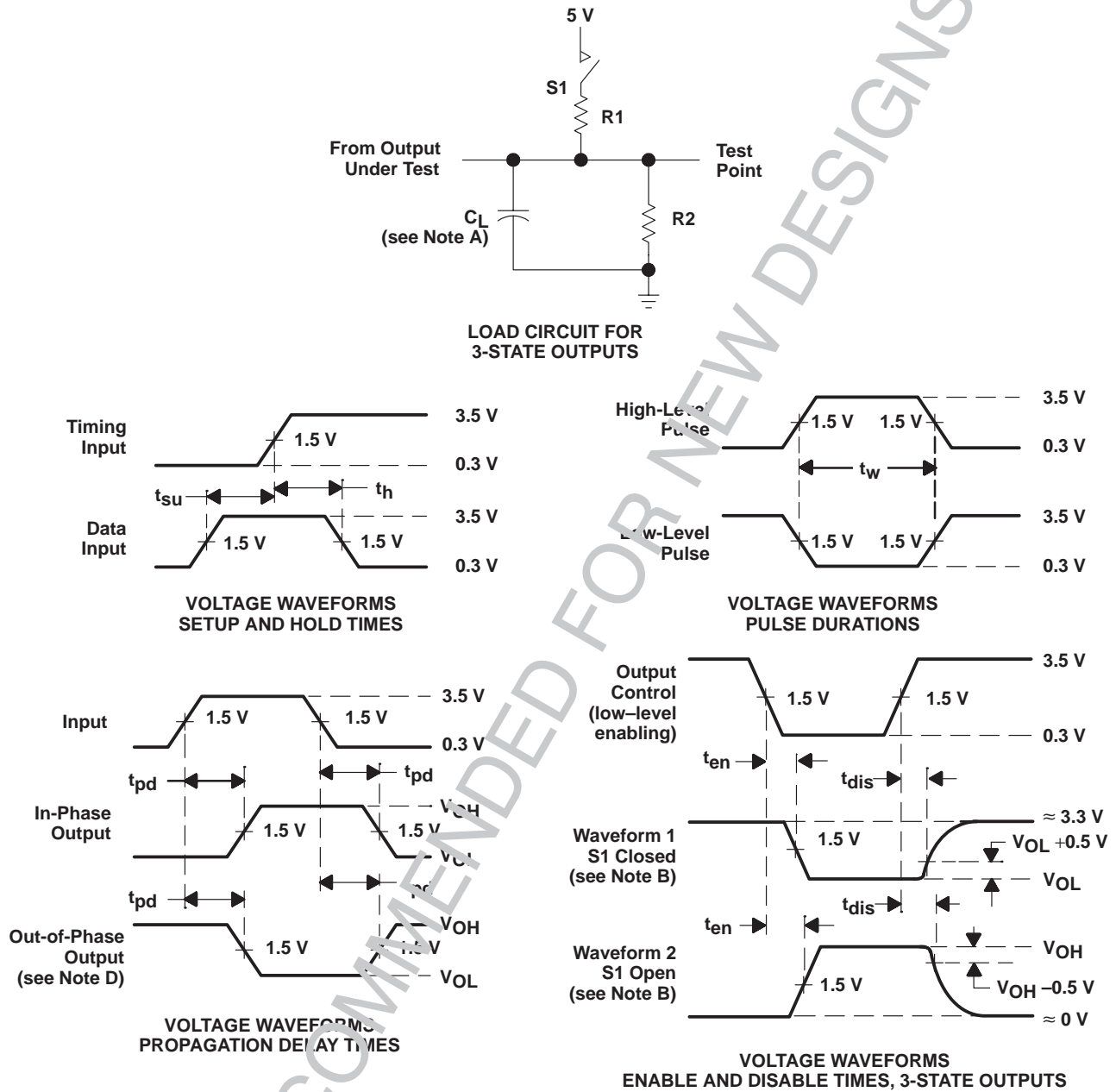

Figure 4

NOT RECOMMENDED FOR NEW DESIGNS

PARAMETER MEASUREMENT INFORMATION



- NOTES: A.  $C_L$  includes probe and jig capacitance and is 50 pF for  $t_{pd}$  and  $t_{en}$ , 5 pF for  $t_{dis}$ .  
 B. Waveform 1 is for an output with internal conditions such that the output is low except when disabled by the output control. Waveform 2 is for an output with internal conditions such that the output is high except when disabled by the output control.  
 C. All input pulses have the following characteristics:  $PRR \leq 1$  MHz,  $t_r = t_f \leq 2$  ns, duty cycle = 50%.  
 D. When measuring propagation delay times of 3-state outputs, switch S1 is closed.  
 E. Equivalent loads may be used for testing.

Figure 5. Load Circuit and Voltage Waveforms

**TIBPLS506AC**  
**13 × 97 × 8 FIELD-PROGRAMMABLE LOGIC SEQUENCER**

SRPS003C – D3090, DECEMBER 1987 – REVISED NOVEMBER 1995

**TYPICAL CHARACTERISTICS**

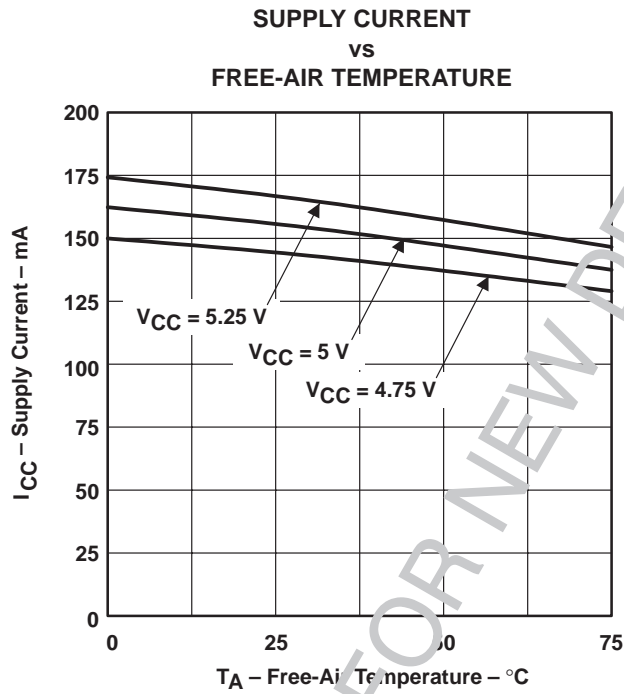

**Figure 6**

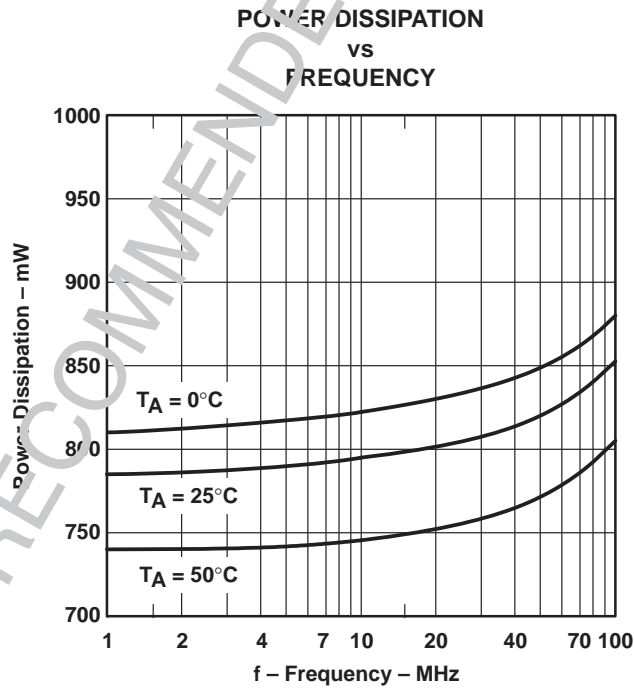

**Figure 7**

NOT RECOMMENDED FOR NEW DESIGNS



TYPICAL CHARACTERISTICS

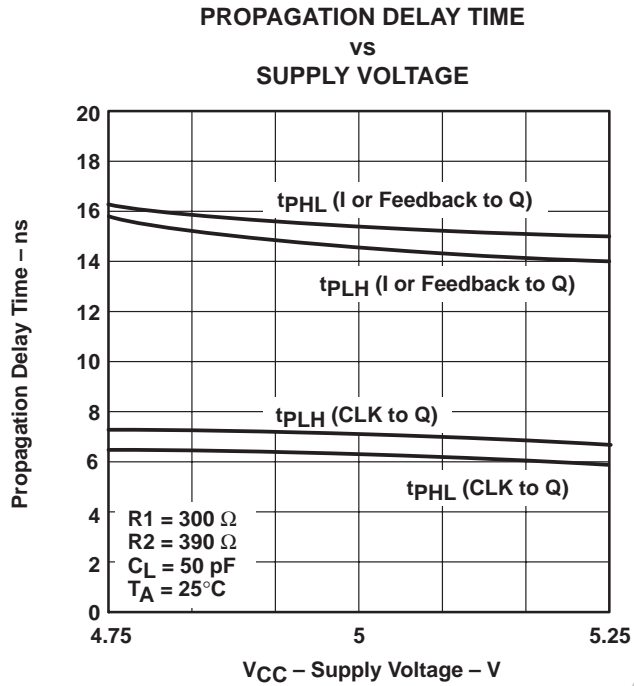

Figure 8

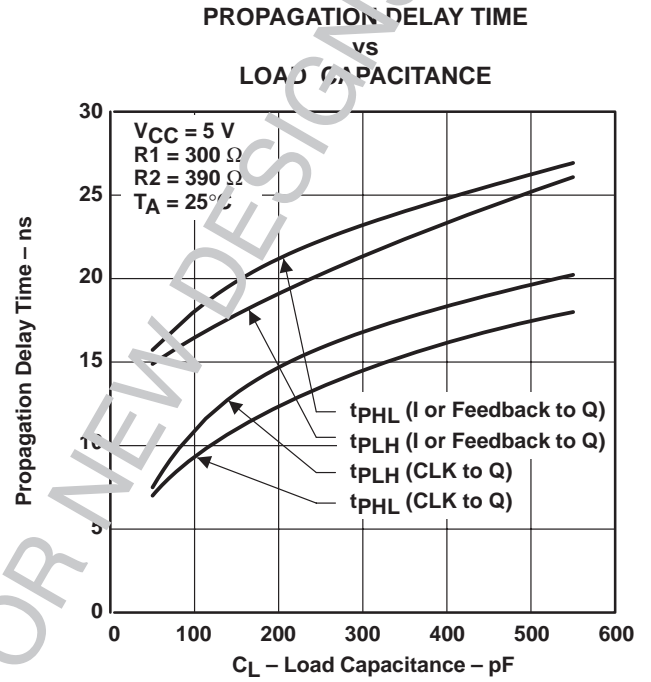

Figure 9

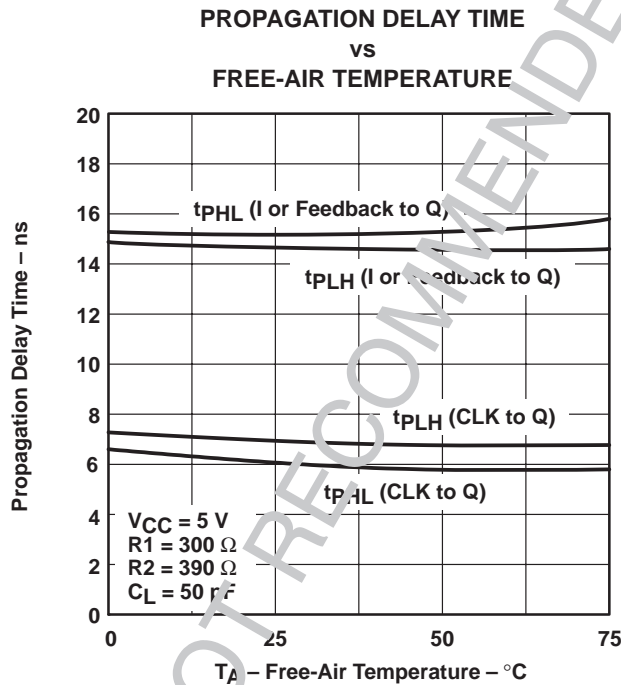

Figure 10

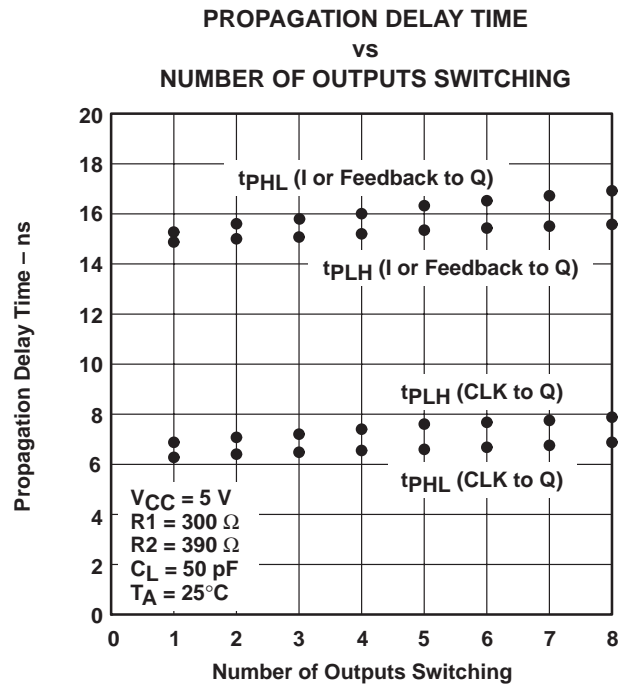

Figure 11

## **IMPORTANT NOTICE**

Texas Instruments and its subsidiaries (TI) reserve the right to make changes to their products or to discontinue any product or service without notice, and advise customers to obtain the latest version of relevant information to verify, before placing orders, that information being relied on is current and complete. All products are sold subject to the terms and conditions of sale supplied at the time of order acknowledgement, including those pertaining to warranty, patent infringement, and limitation of liability.

TI warrants performance of its semiconductor products to the specifications applicable at the time of sale in accordance with TI's standard warranty. Testing and other quality control techniques are utilized to the extent TI deems necessary to support this warranty. Specific testing of all parameters of each device is not necessarily performed, except those mandated by government requirements.

**CERTAIN APPLICATIONS USING SEMICONDUCTOR PRODUCTS MAY INVOLVE POTENTIAL RISKS OF DEATH, PERSONAL INJURY, OR SEVERE PROPERTY OR ENVIRONMENTAL DAMAGE ("CRITICAL APPLICATIONS"). TI SEMICONDUCTOR PRODUCTS ARE NOT DESIGNED, AUTHORIZED, OR WARRANTED TO BE SUITABLE FOR USE IN LIFE-SUPPORT DEVICES OR SYSTEMS OR OTHER CRITICAL APPLICATIONS. INCLUSION OF TI PRODUCTS IN SUCH APPLICATIONS IS UNDERSTOOD TO BE FULLY AT THE CUSTOMER'S RISK.**

In order to minimize risks associated with the customer's applications, adequate design and operating safeguards must be provided by the customer to minimize inherent or procedural hazards.

TI assumes no liability for applications assistance or customer product design. TI does not warrant or represent that any license, either express or implied, is granted under any patent right, copyright, mask work right, or other intellectual property right of TI covering or relating to any combination, machine, or process in which such semiconductor products or services might be or are used. TI's publication of information regarding any third party's products or services does not constitute TI's approval, warranty or endorsement thereof.