

#### FEATURES

- WIDE FREQUENCY RANGE TO 800.00 MHz
- ENABLE/DISABLE AND VOLTAGE CONTROL OPTIONS
- TTL, HCMOS, ACOS, SINEWAVE, CLIPPED SINEWAVE, ECL, AND PECL

#### SPECIFICATIONS

FREQUENCY RANGE	1.00 TO 800.00 MHz (SEE TABLE 1)
FREQUENCY STABILITY OVER OPERATING TEMPERATURE	A: $\pm 0.5$ PPM OVER 0° C TO 50° C B: $\pm 1.0$ PPM OVER 0° C TO 70° C C: $\pm 1.0$ PPM OVER -20° C TO 70° C D: $\pm 1.5$ PPM OVER -30° C TO 75° C E: $\pm 2.0$ PPM OVER -40° C TO 85° C
FREQUENCY STABILITY VS. CALIBRATION	$\pm 1.0$ PPM MAXIMUM
FREQUENCY STABILITY VS. AGING	$\pm 1.0$ PPM MAXIMUM PER YEAR
STORAGE TEMPERATURE RANGE	-50° C TO 90° C
OUTPUT WAVEFORM	SEE TABLE 1 FOR OUTPUT TYPES
LOAD	SEE TABLE 1 FOR LOAD CHARACTERISTICS
FREQUENCY STABILITY VS. LOAD VARIATION	$\pm 0.1$ PPM MAXIMUM FOR $\pm 10\%$ VARIATION FROM STANDARD LOAD
SUPPLY VOLTAGE	+5.0 VDC $\pm 5\%$
FREQUENCY STABILITY VS. SUPPLY VARIATION	$\pm 0.2$ PPM MAXIMUM FOR $\pm 5\%$ VARIATION FROM NOMINAL SUPPLY
SUPPLY CURRENT	SEE TABLE 1 FOR CURRENT CHARACTERISTICS
ENABLE/DISABLE FUNCTION (TE OPTION)	SEE TABLES 2 AND 3 FOR PIN FUNCTION AND VOLTAGE
VOLTAGE CONTROL FUNCTION (TV OPTION)	SEE TABLE 4 FOR CHARACTERISTICS
ENVIRONMENTAL CONDITIONS	SEE TABLE 5



#### OUTPUT WAVEFORM AND LOAD CHARACTERISTICS

TABLE 1 - OUTPUT WAVEFORM AND CHARACTERISTICS, FREQUENCY RANGE, AND MODE OF OSCILLATION

OUTPUT WAVEFORM	OUTPUT CODE	FREQUENCY RANGE	MODE OF OSCILLATION CODE	OUTPUT CHARACTERISTICS
CLIPPED SINEWAVE	0	8.00 MHz TO 40.00 MHz	F: FUNDAMENTAL	LOAD: 10 K OHM // 10pF OUTPUT LEVEL: 0.7 V P-P MINIMUM SYMMETRY: 60/40 % TO 40/60 % TYPICAL
TTL	1	1.00 MHz TO 30.00 MHz 30.00 MHz TO 100.00 MHz 32.00 MHz TO 160.00 MHz	F: FUNDAMENTAL O: OVERTONE P: PHASE LOCKED LOOP (PLL)	LOAD: HCMOS TO DRIVE 2 LS TTL NOMINAL OR 10 LS TTL MAXIMUM GATES "1" LEVEL: +2.4 VDC MINIMUM "0" LEVEL: +0.1 VCC MAXIMUM SYMMETRY: 40/60 TO 60/40% AT 1.2 V RISE AND FALL TIME: 10 ns MAXIMUM CURRENT: 20 mA MAXIMUM (F), 30 mA MAXIMUM (O), 45 mA MAXIMUM (PLL)
HCMOS	2	1.00 MHz TO 30.00 MHz 36.00 MHz TO 100.00 MHz 32.00 MHz TO 160.00 MHz	F: FUNDAMENTAL O: OVERTONE P: PHASE LOCKED LOOP (PLL)	LOAD: 2 LS TTL/HCMOS NOMINAL OR 10 LS TTL/HCMOS MAXIMUM GATES "1" LEVEL: +4.5 VDC MINIMUM "0" LEVEL: +0.5 VDC MAXIMUM SYMMETRY: 40/60 TO 60/40% AT 50% VCC LEVEL RISE AND FALL TIME: 10 ns MAXIMUM JITTER: 10 ps PEAK TO PEAK MAXIMUM CURRENT: 20 mA MAXIMUM (F), 30 mA MAXIMUM (O), 45 mA MAXIMUM (PLL)
ACMOS	3	1.00 MHz TO 30.00 MHz 36.00 MHz TO 100.00 MHz 32.00 MHz TO 160.00 MHz	F: FUNDAMENTAL O: OVERTONE P: PHASE LOCKED LOOP (PLL)	LOAD: 2 LS TTL/ACMOS NOMINAL OR 10 LS TTL/ACMOS MAXIMUM GATES "1" LEVEL: +4.5 VDC MINIMUM "0" LEVEL: +0.5 VDC MAXIMUM SYMMETRY: 40/60 TO 60/40% AT 50% VCC LEVEL RISE AND FALL TIME: 10 ns MAXIMUM JITTER: 10 ps PEAK TO PEAK MAXIMUM CURRENT: 20 mA MAXIMUM (F), 30 mA MAXIMUM (O), 45 mA MAXIMUM (PLL)
SINEWAVE	6	8.00 MHz TO 40.00 MHz	F: FUNDAMENTAL	LOAD: 50 OHMS NOMINAL OUTPUT LEVEL: 0 dBm MINIMUM HARMONICS: -25 dBc MAXIMUM SPURIOUS: -60 dBc MAXIMUM CURRENT: 20 mA MAXIMUM
ECL	7	100.00 MHz TO 800.00 MHz	P: PHASE LOCKED LOOP (PLL)	LOAD: 50 OHMS CONNECTED TO +3.0 VDC "1" LEVEL: +3.975 VDC MINIMUM "0" LEVEL: +3.38 VDC MAXIMUM SYMMETRY: 40/60 TO 60/40% AT +3.65 VDC LEVEL RISE AND FALL TIME: 5 ns MAXIMUM JITTER: 10 ps PEAK TO PEAK MAXIMUM CURRENT: 130 mA MAXIMUM
PECL	8	100.00 MHz TO 800.00 MHz	P: PHASE LOCKED LOOP (PLL)	LOAD: 50 OHMS CONNECTED TO +3.0 VDC "1" LEVEL: +3.975 VDC MINIMUM "0" LEVEL: +3.38 VDC MAXIMUM SYMMETRY: 40/60 TO 60/40% AT +3.65 VDC LEVEL RISE AND FALL TIME: 5 ns MAXIMUM JITTER: 10 ps PEAK TO PEAK MAXIMUM CURRENT: 130 mA MAXIMUM

● **OUTLINE DRAWING**

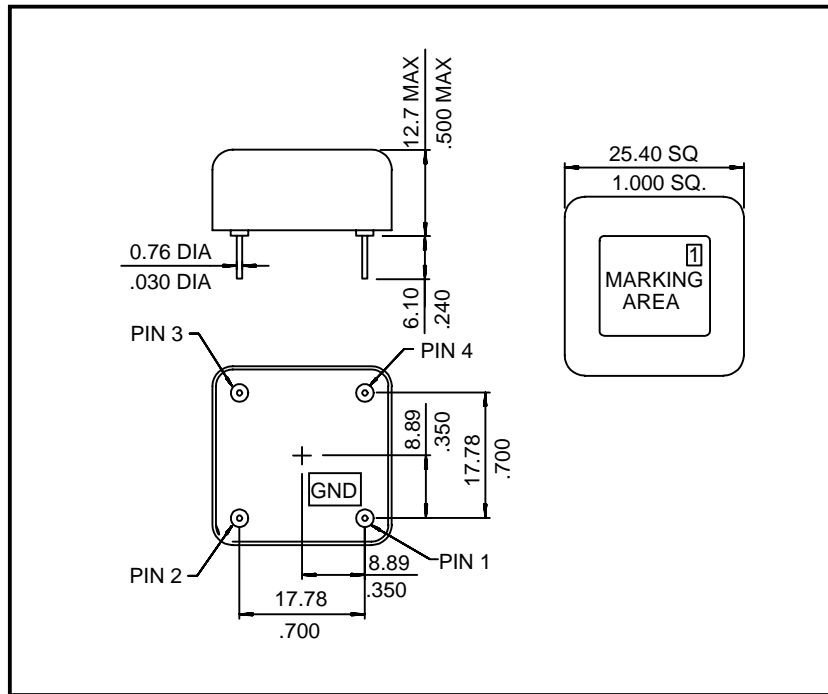

● **PIN FUNCTION**

TABLE 2 - PIN FUNCTION			
	TX	TE	TV
PIN 1	CASE/GROUND	CASE/GROUND	CASE/GROUND
PIN 2	NO CONNECT	ENABLE/DISABLE	V CONT
PIN 3	OUTPUT	OUTPUT	OUTPUT
PIN 4	VCC	VCC	VCC

● **ENABLE/DISABLE FUNCTION**

TABLE 3 - ENABLE/DISABLE FUNCTION	
ENABLE	+2.0 VDC MINIMUM OR NO CONNECT
DISABLE	+0.4 VDC MAXIMUM

● **VOLTAGE CONTROL FUNCTION**

TABLE 4 - VOLTAGE CONTROL OPTION	
CONTROL VOLTAGE RANGE	+0.5 TO +4.5 VDC
NOMINAL CONTROL VOLTAGE	+2.5 VDC
FREQUENCY DEVIATION	±10 PPM MINIMUM
LINEARITY	10% MAXIMUM MONOTONIC
MODULATION BANDWIDTH	10 KHz MINIMUM FOR -3 dBc POINT
INPUT IMPERDANCE	10 K OHMS MINIMUM
SLOPE	POSITIVE

● **ENVIRONMENTAL CONDITIONS**

TABLE 5 - ENVIRONMENTAL CONDITIONS	
MECHANICAL SHOCK	MIL-STD-202F, TEST CONDITION 213, CONDITION A
RANDOM VIBRATION	MIL-STD-202F, TEST CONDITION 214, CONDITION A
SINUSOIDAL VIBRATION	MIL-STD-202F, TEST CONDITION 204, CONDITION A
HERMETICITY	<5 x 10 <sup>-8</sup> cc ATM/s
SOLDERABILITY	260° C FOR 10 s MAXIMUM

### SERIES TX 048 AND TV048

#### ● PHASE NOISE CHARACTERISTICS

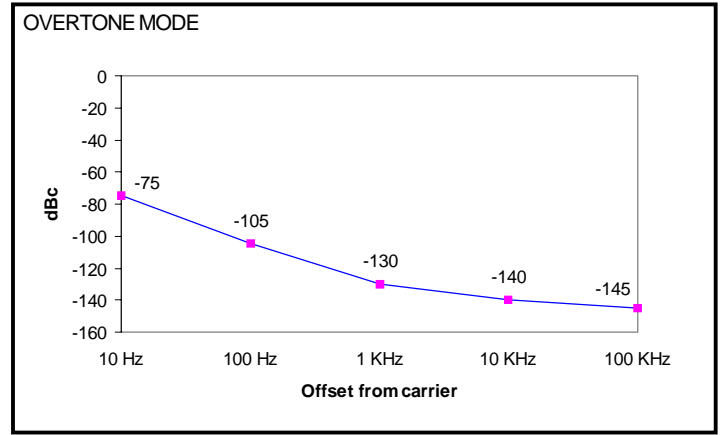
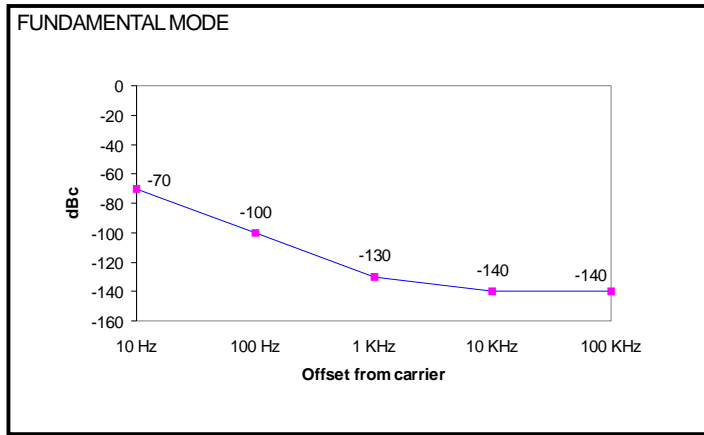

#### ● PART NUMBERING SYSTEM

OPTION1: TCXO TYPE			
TX:	TCXO		
TE:	TCXO WITH ENABLE DISABLE		
TV:	TCXO WITH VOLTAGE CONTROL		
OPTION2: MODE OF REFERENCE OSCILLATION			
F:	FUNDAMENTAL		
O:	OVERTONE		
S:	PHASE LOCKED LOOP		
OPTION 3: OUTPUT TYPE			
0:	CLIPPED SINEWAVE	6:	SINEWAVE
1:	TTL	7:	ECL
2:	HCMOS	8:	PECL
3:	ACMOS		
OPTION 4: STABILITY OVER TEMPERATURE			
A:	±0.5 PPM OVER 0 °C TO +50 °C		
B:	±1.0 PPM OVER 0 °C TO +70 °C		
C:	±1.0 PPM OVER -20 °C TO +70 °C		
D:	±1.5 PPM OVER -30 °C TO +75 °C		
E:	±2.0 PPM OVER -40 °C TO +85 °C		

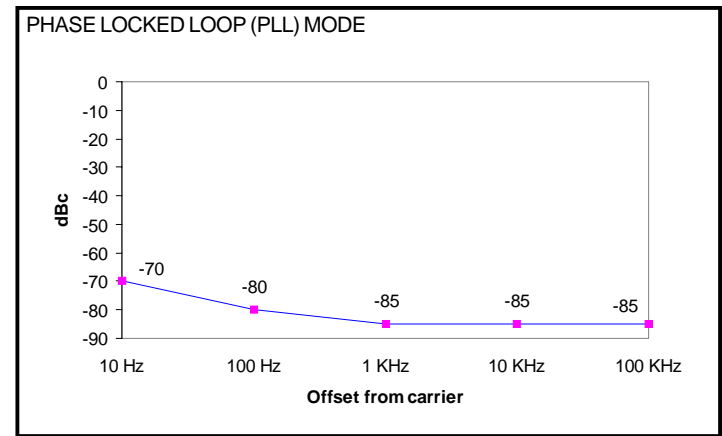

#### EXAMPLE:

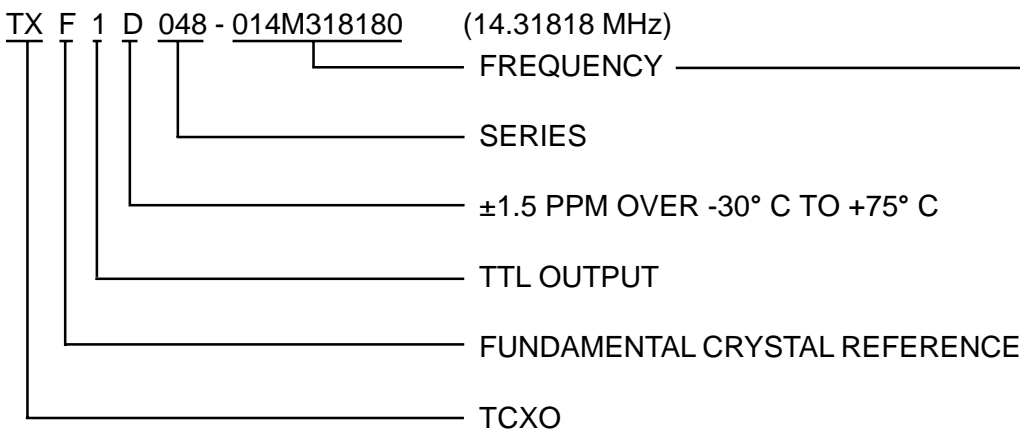

FREQUENCY FORMAT	
FFF(UNIT)FFFFF	
EXAMPLE	
10.00 MHz	010M000000
24.576 MHz	024M576000