



LXT332

Dual T1/E1 Line Interface Unit with Crystal-less Jitter Attenuation

Datasheet

The LXT332 is a fully integrated Dual Line Interface Unit (DLIU) for both 1.544 Mbps (T1) and 2.048 Mbps (E1) applications. It features B8ZS/HDB3 encoders and decoders, and a constant low output impedance transmitter for high return loss. Transmit pulse shape is selectable for various line lengths and cable types.

The LXT332 incorporates an advanced crystal-less digital jitter attenuator, switchable to either the transmit or receive side. This eliminates the need for an external quartz crystal. It offers both a serial interface (SIO) for microprocessor control and a hardware control mode for stand-alone operation.

The LXT332 offers a variety of advanced diagnostic and performance monitoring features. It uses an advanced double-poly, double-metal CMOS process and requires only a single 5-volt power supply.

Applications

- PCM/Voice Channel Banks
- Data Channel Bank/Concentrator
- T1/E1 multiplexer
- Digital Access and Cross-connect Systems (DACS)
- Computer to PBX interface (CPI & DMI)
- SONET/SDH Multiplexers
- Interfacing Customer Premises Equipment to a CSU
- Digital Loop Carrier (DLC) terminals

Product Features

- Digital (crystal-less) jitter attenuation, selectable for receive or transmit path, or may be disabled
- High transmit and receive return loss
- Constant low output impedance transmitter with programmable equalizer shapes pulses to meet DSX-1 pulse template from 0 to 655 ft.
- Meets or exceeds industry specifications including ITU G.703, ANSI T1.403, AT&T Pub 62411 and ITU-T G.742
- Compatible with most industry standard framers
- Complete line driver, data recovery and clock recovery functions
- Minimum receive signal of 500 mV, with selectable slicer levels to improve SNR
- Local, remote, and dual loopback functions
- Built-In Self Test with QRSS Pattern Generator
- Transmit/Receive performance monitors with Driver Fail Monitor (DFM) and Loss of Signal (LOS) outputs
- Receiver jitter tolerance 0.4 UI from 40 kHz to 100 kHz
- Available in 44-pin PLCC and 44-pin QFP packages



Information in this document is provided in connection with Intel® products. No license, express or implied, by estoppel or otherwise, to any intellectual property rights is granted by this document. Except as provided in Intel's Terms and Conditions of Sale for such products, Intel assumes no liability whatsoever, and Intel disclaims any express or implied warranty, relating to sale and/or use of Intel products including liability or warranties relating to fitness for a particular purpose, merchantability, or infringement of any patent, copyright or other intellectual property right. Intel products are not intended for use in medical, life saving, or life sustaining applications.

Intel may make changes to specifications and product descriptions at any time, without notice.

Designers must not rely on the absence or characteristics of any features or instructions marked "reserved" or "undefined." Intel reserves these for future definition and shall have no responsibility whatsoever for conflicts or incompatibilities arising from future changes to them.

The LXT332 may contain design defects or errors known as errata which may cause the product to deviate from published specifications. Current characterized errata are available on request.

Contact your local Intel sales office or your distributor to obtain the latest specifications and before placing your product order.

Copies of documents which have an ordering number and are referenced in this document, or other Intel literature may be obtained by calling 1-800-548-4725 or by visiting Intel's website at <http://www.intel.com>.

Copyright © Intel Corporation, 2001

*Third-party brands and names are the property of their respective owners.

Contents

| | | |
|------------|--|----|
| 1.0 | Overview | 6 |
| 1.1 | Standard LXT332 Features | 6 |
| 1.1.1 | Tri-state Outputs..... | 6 |
| 1.1.2 | Bipolar or Unipolar Data I/O | 6 |
| 1.1.3 | B8ZS or HDB3 Zero Suppression | 6 |
| 1.1.4 | Selectable Jitter Attenuation..... | 6 |
| 1.1.5 | Dual Loopback | 6 |
| 1.2 | Additional Host-Mode Features | 6 |
| 1.2.1 | High Frequency Clocks | 6 |
| 1.2.2 | Bipolar Violation Insertion..... | 7 |
| 1.2.3 | Built-In Self Test (QRSS) | 7 |
| 1.2.4 | AIS Detection | 7 |
| 2.0 | Pin Assignments and Signal Descriptions | 8 |
| 3.0 | Functional Description | 16 |
| 3.1 | Receiver | 16 |
| 3.2 | Transmitter | 17 |
| 3.2.1 | Bipolar Violation Insertions..... | 17 |
| 3.2.2 | Pulse Shape | 18 |
| 3.3 | Driver Failure Monitor..... | 18 |
| 3.4 | Jitter Attenuation | 19 |
| 3.5 | Built-In Self Test..... | 19 |
| 3.6 | Operating Modes..... | 19 |
| 3.7 | Host Mode Control | 19 |
| 3.7.1 | Serial Input Word..... | 20 |
| 3.7.2 | Serial Output Word..... | 20 |
| 3.7.3 | Interrupt Handling..... | 24 |
| 3.8 | Hardware Mode Control | 24 |
| 3.9 | Diagnostic Mode Operation..... | 24 |
| 3.9.1 | Transmit All Ones (See Figure 8)..... | 24 |
| 3.9.2 | Local Loopback (See Figure 9 and Figure 10) | 25 |
| 3.9.3 | Remote Loopback (See Figure 11) | 26 |
| 3.9.4 | Dual Loopback (See Figure 12) | 27 |
| 3.9.5 | QRSS Built-In Self Test - Host Mode | 27 |
| 3.10 | Initialization/Reset Operation | 28 |
| 4.0 | Application Information | 29 |
| 4.1 | Power Requirements..... | 29 |
| 4.2 | Transformers | 29 |
| 4.3 | Line Protection | 29 |
| 4.4 | 1.544 Mbps T1 Applications | 29 |
| 4.5 | 2.048 Mbps E1/CEPT Interface Applications | 32 |
| 4.5.1 | E1 Coaxial Applications..... | 32 |
| 4.5.2 | E1 Twisted-Pair Applications..... | 32 |

| | | |
|------------|--|----|
| 5.0 | Test Specifications | 34 |
| 6.0 | Mechanical Specifications | 41 |

Figures

| | | |
|----|--|----|
| 1 | LXT332 Block Diagram | 5 |
| 2 | LXT332 Pin Assignments and Package Markings (PLCC) | 8 |
| 3 | LXT332 Pin Assignments and Package Markings (QFP Package) | 9 |
| 4 | 50% AMI Coding | 17 |
| 5 | LXT332 SIO Write Operation | 22 |
| 6 | LXT332 SIO Read Operation | 22 |
| 7 | LX332 Interrupt Handling | 23 |
| 8 | TAOS Data Path | 25 |
| 9 | TAOS with LLOOP & Selectable JA..... | 25 |
| 10 | Local Loopback - Selectable JA..... | 26 |
| 11 | Remote Loopback - Selectable JA..... | 27 |
| 12 | Dual Loopback | 27 |
| 13 | QRSS BIST | 28 |
| 14 | Typical LXT332 T1 Application (Host Control Mode, Bipolar I/O) | 31 |
| 15 | Line Interface for E1 Coax Applications | 32 |
| 16 | Typical LXT332 E1 120 W Application (Hardware Control Mode) | 33 |
| 17 | LXT332 Serial Data Input Timing Diagram | 36 |
| 18 | LXT332 Serial Data Output Timing Diagram..... | 37 |
| 19 | LXT332 Receive Clock Timing..... | 37 |
| 20 | LXT332 Transmit Clock Timing..... | 37 |
| 21 | Typical Receiver Input Jitter Tolerance (Loop Mode) | 39 |
| 22 | Typical Jitter Transfer Performance | 40 |
| 23 | LXT332 PLCC Package Specifications..... | 41 |
| 24 | LXT332 QFP Package Specifications | 42 |

Tables

| | | |
|----|--|----|
| 1 | Host Mode and Bipolar Host Mode Pin Descriptions | 10 |
| 2 | Unipolar Host Mode Pin Descriptions1 | 12 |
| 3 | Hardware Mode and Bipolar Hardware Mode Pin Descriptions1 | 13 |
| 4 | Unipolar Hardware Mode Pin Descriptions1 | 15 |
| 5 | Equalizer Control Inputs..... | 18 |
| 6 | CLKE Settings..... | 20 |
| 7 | SIO Input Bit Settings (See Figure 5)..... | 21 |
| 8 | LXT332 Serial Data Output Bit Coding (See Figure 6) | 21 |
| 9 | Recommended Transformer Values | 30 |
| 10 | Transformer Combinations..... | 30 |
| 11 | Absolute Maximum Ratings | 34 |
| 12 | Recommended Operating Conditions | 34 |
| 13 | Electrical Characteristics (Over Recommended Operating Conditions) | 34 |
| 14 | Analog Specifications (Over Recommended Operating Conditions) | 35 |
| 15 | LXT332 Serial I/O Timing Characteristics (See Figure 17 and Figure 18)..... | 36 |
| 16 | LXT332 Receive Timing Characteristics (See Figure 19) | 38 |
| 17 | LXT332 Master Clock and Transmit Timing Characteristics (See Figure 20) | 38 |

Figure 1. LXT332 Block Diagram

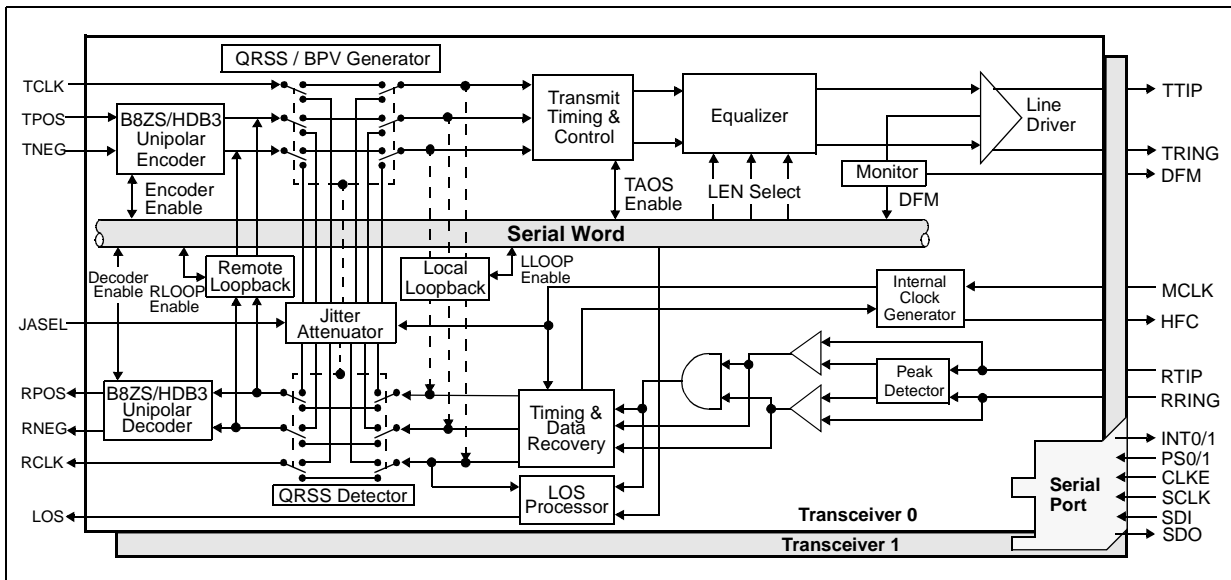

1.0 Overview

In addition to the inherent advantages of a dual LIU, the LXT332 also provides several advanced features that are not available in other LXT300-series devices. All of the added features are easily implemented. Many require only a clock pulse to change from one mode to another. Some features are available in Host mode only.

1.1 Standard LXT332 Features

1.1.1 Tri-state Outputs

All LXT332 output pins can be forced to tri-state (high-Z). Tri-state is controlled by the TRSTE pin.

1.1.2 Bipolar or Unipolar Data I/O

The LXT332 to framer interface can be either bipolar (default) or unipolar (selectable). The unipolar I/O mode is selected by applying MCLK to the TRSTE pin.

1.1.3 B8ZS or HDB3 Zero Suppression

The LXT332 incorporates zero suppression encoders and decoders for use in the unipolar data I/O mode. The encoders/decoders can be activated or deactivated by changing the logic level on the re-mapped TNEG pin.

1.1.4 Selectable Jitter Attenuation

Jitter attenuation can be placed in either the transmit or receive path or deactivated. The Jitter Attenuation Select (JASEL) pin selects the jitter attenuation path. No crystal is required.

1.1.5 Dual Loopback

Dual Loopback (DLOOP) enables simultaneous loopbacks to both the framer and the line. The TCLK, TPOS and TNEG framer inputs are routed through the jitter attenuator and looped back to the RCLK, RPOS and RNEG outputs. The RTIP/RRING line inputs are looped back through the timing recovery block and line driver onto the TTIP/TRING outputs.

1.2 Additional Host-Mode Features

1.2.1 High Frequency Clocks

The LXT332 provides a pair of high frequency clock outputs, one for each LIU. These 8x clocks (12.352 MHz for T1, 16.384 MHz for E1) are tied to the de-jittered clock from the JA of the respective LIU.

1.2.2 Bipolar Violation Insertion

The same pins which provide the high frequency clocks can also be used to insert bipolar violations into the outgoing data stream. Violations can be inserted into each LIU port independently.

1.2.3 Built-In Self Test (QRSS)

The LXT332 can generate and transmit a Quasi Random Signal Source (QRSS) pattern to Built-In Self Test (BIST) applications. Logic errors and bipolar violations can be inserted into the QRSS output. The LXT332 also detects QRSS pattern synchronization and reports bit errors in the received QRSS pattern data stream.

1.2.4 AIS Detection

The LXT332 detects the AIS alarm signal on the receive side independent of the loopback modes. When AIS is detected (less than 3 zeros in 2048 bits), the LXT332 provides an indicator output.

2.0 Pin Assignments and Signal Descriptions

Figure 2 and Figure 3 identify the pins and signals for the PLCC and QFP packages, respectively. Note that many pins have two functions. The active function is determined by the particular mode of operation selected. Table 1 describes the Host mode signal functions, except signals that change when in Unipolar Host mode. Table 2 describes signal functions that change when in Unipolar Most mode. Table 3 describes all Hardware mode signal functions, except signals that change when in Unipolar mode. Table 4 describes signal functions that change when Unipolar Hardware mode is selected.

Figure 2. LXT332 Pin Assignments and Package Markings (PLCC)

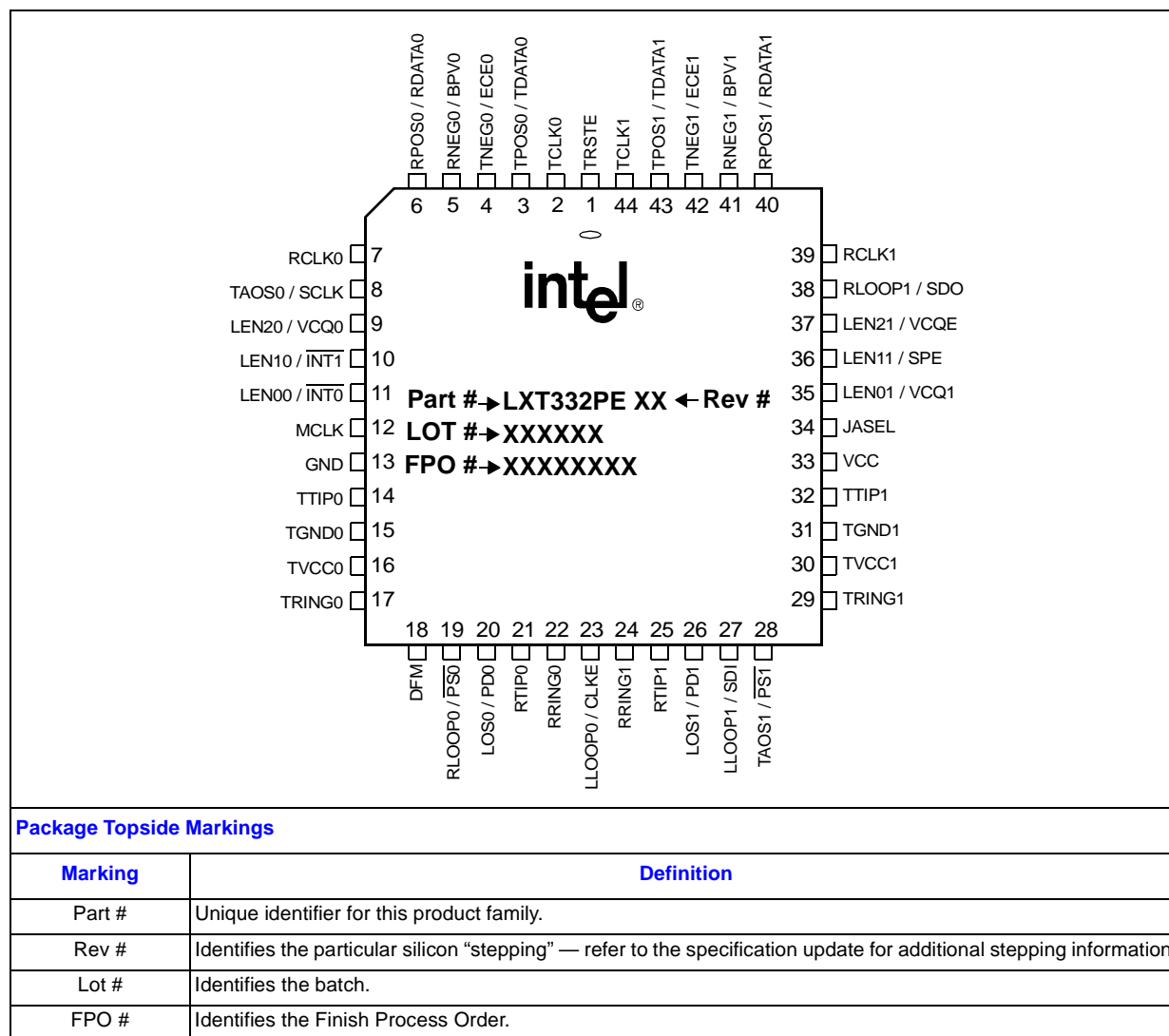
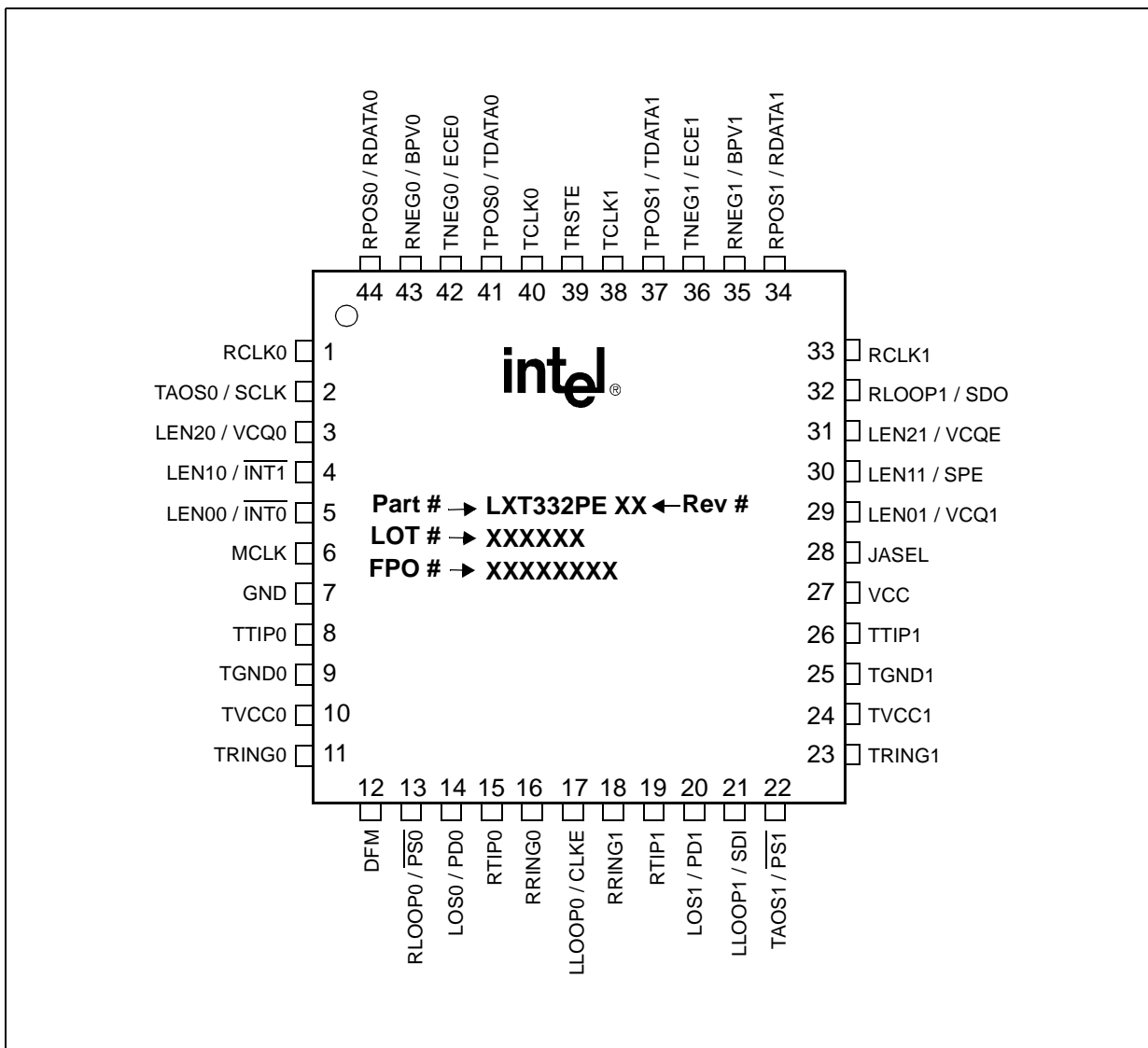

Figure 3. LXT332 Pin Assignments and Package Markings (QFP Package)



Package Topside Markings

| Marking | Definition |
|---------|---|
| Part # | Unique identifier for this product family. |
| Rev # | Identifies the particular silicon "stepping" — refer to the specification update for additional stepping information. |
| Lot # | Identifies the batch. |
| FPO # | Identifies the Finish Process Order. |

Table 1. Host Mode and Bipolar Host Mode Pin Descriptions

| Pin QFP | Pin PLCC | Symbol | I/O ¹ | Description |
|---------|----------|--------------------------|------------------|--|
| 39 | 1 | TRSTE | DI | Tristate Output Enable. When held High, forces all output pins to high-Z (tri-state). When held Low, Bipolar I/O mode is selected. In this mode, the framer interface is bipolar (TPOS/TNEG and RPOS/RNEG), and the B8ZS/HDB3 encoders are disabled. When clocked by MCLK, Unipolar I/O mode is selected. In this mode, the framer interface is unipolar (TDATA and RDATA), and the TNEG and RNEG pins are re-mapped. The TNEG pins are re-mapped as Encoder Enables (ECE) to individually enable the B8ZS/HDB3 encoder/decoder for each port. The RNEG pins are re-mapped as Bipolar Violation (BPV) indicators to report BPVs detected at the respective ports. |
| 40 | 2 | TCLK0 | DI | Transmit Clock - Port 0. 1.544 MHz for T1, 2.048 MHz for E1. The port 0 transmit data inputs are sampled on the falling edge of TCLK0. |
| 41 | 3 | TPOS0 (Bipolar) | DI | Transmit Positive and Negative Data - Port 0. In the Bipolar I/O mode, these pins are the positive and negative sides of a bipolar input pair for port 0. Data to be transmitted onto the twisted-pair line is input at these pins. |
| 42 | 4 | TNEG0 (Bipolar) | DI | |
| 43 | 5 | RNEG0 (Bipolar) | DO | Receive Positive and Negative Data - Port 0. In the Bipolar I/O mode, these pins are the data outputs from port 0. A signal on RNEG corresponds to receipt of a negative pulse on RTIP/RRING. A signal on RPOS corresponds to receipt of a positive pulse on RTIP/RRING. RNEG/RPOS outputs are Non Return-to-Zero (NRZ). The CLKE pin determines the clock edge at which these outputs are stable and valid. |
| 44 | 6 | RPOS0 (Bipolar) | DO | |
| 1 | 7 | RCLK0 | DO | Receive Clock - Port 0. Normally, this clock is recovered from the input signal. Under Loss of Signal (LOS) conditions, RCLK0 is derived from MCLK. |
| 2 | 8 | SCLK | DI | Serial Clock. SCLK shifts data into or out of the serial interface register of the selected port. |
| 3 | 9 | VCQ0 | DI/O | Violation Insert, High Frequency Clock, or QRSS - Port 0. The function of this pin is selected by the VCQE pin. When VCQE is High, the Bipolar Violation (BPV) insertion function is selected. VCQ0 is an input that is sampled on the falling edge of TCLK0 to control BPV insertion. When VCQ0 is High, a BPV is inserted at the next available mark transmitted from port 0. A Low-to-High transition is required for each subsequent BPV insertion. B8ZS and HDB3 zero suppression codes are not violated. When VCQE is Low, the High Frequency Clock (HFC) function is selected. VCQ0 outputs a HFC (12.352 MHz for T1, 16.384 MHz for E1) tied to the jitter attenuated clock of the port 0. If no JA clock is available, the HFC is locked to the 8x receive timing recovery clock. When VCQE is clocked with MCLK, the Quasi Random Signal Source (QRSS) function is selected. A High on VCQ0 enables the QRSS detection circuit and causes the LXT332 to transmit the QRSS pattern onto the twisted-pair line from port 0. For error-free QRSS transmission, TPOS0 must be held Low. To insert errors into the pattern, TPOS0 must transition from Low to High (TPOS0 is sampled on the falling edge of MCLK). A Low to High transition is required for each subsequent violation insertion. B8ZS and HDB3 zero suppression codes are not violated. |
| 4 | 10 | $\overline{\text{INT1}}$ | DO | Interrupt Outputs. The interrupt outputs go Low to flag the host processor that the respective port has changed state. INT0 and INT1 are open drain outputs. Each interrupt signal must be tied to VCC through a resistor. |
| 5 | 11 | $\overline{\text{INT0}}$ | DO | |
| 6 | 12 | MCLK | DI | Master Clock. The master clock (1.544 MHz for T1, 2.048 MHz for E1) must be independent, free-running, continuously active and jitter free for receiver operation. Note that MCLK cannot be derived from RCLK because during a Loss of Signal (LOS) condition, transceiver timing is based on MCLK. |

1. DI = Digital Input; DO = Digital Output; DI/O = Digital Input/Output; AI = Analog Input; AO = Analog Output; S = Power Supply.

Table 1. Host Mode and Bipolar Host Mode Pin Descriptions (Continued)

| Pin QFP | Pin PLCC | Symbol | I/O ¹ | Description |
|---|----------|------------------|------------------|---|
| 7 | 13 | GND | S | Ground. Ground return for the VCC power supply. |
| 8 11 | 14 17 | TTIP0 TRING0 | AO AO | Transmit Tip and Ring - Port 0. These pins are differential driver outputs designed to drive a 35 - 200 Ω load. Line matching resistors and transformers can be selected to give the desired pulse height. See Table 10 and Figure 14 through Figure 16 for details. |
| 9 | 15 | TGND0 | S | Ground - Port 0 Transmit Driver. Ground return for the TVCC0 power supply. |
| 10 | 16 | TVCC0 | S | + 5 VDC - Port 0 Transmit Driver. TVCC0 must not vary from TVCC1 or VCC by more than ± 0.3 V. |
| 12 | 18 | DFM | DO | Driver Failure Monitor. This signal goes High to indicate a driver output short in one or both ports. |
| 13 | 19 | $\overline{PS0}$ | DI | Port Select - Port 0. This signal selects the serial interface registers for port 0. For each read or write operation, $\overline{PS0}$ must transition from High to Low, and remain Low. |
| 14 | 20 | PD0 | DO | Pattern Detect - Port 0. Unless the QRSS function is selected by the VCQE pin, PD0 functions as an Alarm Indication Signal (AIS). The AIS pattern is detected by the receiver, independent of any loopback mode. PD0 goes High when less than three zeros have been detected in any string of 2048 bits. PD0 returns Low when the received signal contains more than three zeros in 2048 bits. If the QRSS function is enabled by the VCQE pin, PD0 remains High until pattern sync is reached with the received signal. Once pattern lock is obtained, PD0 goes Low. The sync/out-of-sync criteria is: less than 3/4 errors in 128 bits. After sync acquisition, bit errors cause PD0 to go High for half a clock cycle. PD0 can be used to trigger an external error counter. |
| 15 16 | 21 22 | RTIP0 RRING0 | AI AI | Receive Tip and Ring - Port 0. These pins comprise the receive line interface and should be connected to the line through a center-tapped 1:2 transformer. See Figure 14 through Figure 16 for details. |
| 17 | 23 | CLKE | DI | Clock Edge Select. When CLKE is High, RPOS/RNEG or RDATA outputs are valid on the falling edge of RCLK, and SDO is valid on the rising edge of SCLK. When CLKE is Low, RPOS/RNEG or RDATA outputs are valid on the rising edge of RCLK, and SDO is valid on the falling edge of SCLK. |
| 18 19 | 24 25 | RRING1 RTIP1 | AI AI | Receive Tip and Ring - Port 1. These pins comprise the receive line interface and should be connected to the line through a center-tapped 1:2 transformer. See Figure 14 through Figure 16 for details. |
| 20 | 26 | PD1 | DO | Pattern Detect - Port 1. Reports AIS and QRSS pattern reception. See PD0 signal description for details. |
| 21 | 27 | SDI | DI | Serial Data Input. Write data to the LXT332 registers is input on this pin. SDI is sampled on the rising edge of SCLK. |
| 22 | 28 | $\overline{PS1}$ | DI | Port Select - Port 1. Selects the serial interface registers for port 1. For each read or write operation, $\overline{PS1}$ must transition from High to Low, and remain Low. |
| 23 26 | 29 32 | TRING1 TTIP1 | AO AO | Transmit Tip and Ring - Port 1. These pins are differential driver outputs designed to drive a 35 - 200 Ω load. Line matching resistors and transformers can be selected to give the desired pulse height. See Table 10 and Figure 14 through Figure 16 for details. |
| 24 | 30 | TVCC1 | S | + 5 VDC - Port 1 Transmit Driver. TVCC1 must not vary from TVCC0 or VCC by more than ± 0.3 V. |
| 25 | 31 | TGND1 | S | Ground - Port 1 Transmit Driver. Ground return for the TVCC1 power supply. |
| 27 | 33 | VCC | S | +5 VDC. Power supply for all circuits except the transmit drivers. |
| 1. DI = Digital Input; DO = Digital Output; DI/O = Digital Input/Output; AI = Analog Input; AO = Analog Output; S = Power Supply. | | | | |

Table 1. Host Mode and Bipolar Host Mode Pin Descriptions (Continued)

| Pin QFP | Pin PLCC | Symbol | I/O ¹ | Description |
|---|----------|--------------------|------------------|--|
| 28 | 34 | JASEL | DI | Jitter Attenuation Select. When JASEL is High, the Jitter Attenuation (JA) circuits are placed in the receive paths. When JASEL is Low, the JA circuits are placed in the transmit paths. When JASEL is clocked with MCLK, the JA circuits are disabled. |
| 29 | 35 | VCQ1 | DI/O | Violation Insert, High Frequency Clock, or QRSS - Port 1. The function of this pin is selected by the VCQE pin. Refer to VCQ0 signal description for details. |
| 30 | 36 | SPE | DI | Serial Port Enable. When clocked with MCLK, Host mode is enabled. In Host mode the LXT332 is controlled by a μ P via the serial port. |
| 31 | 37 | VCQE | DI | Violation Insert, High Frequency Clock, QRSS Enable. When set High, selects the Bipolar Violation (BPV) insertion function on VCQ0 and VCQ1. When set Low, selects the High Frequency Clock (HFC) function on VCQ0 and VCQ1. When clocked with MCLK, selects the Quasi Random Signal Source (QRSS) function on VCQ0 and VCQ1, and enables the QRSS Generate and Detect function on PD0 and PD1. |
| 32 | 38 | SDO | DO | Serial Data Output. This pin carries read data from the LXT332 registers. When CLKE is High, SDO is valid on the rising edge of SCLK. When CLKE is Low, SDO is valid on the falling edge of SCLK. |
| 33 | 39 | RCLK1 | DO | Receive Clock - Port 1. Normally, this clock is recovered from the port 1 input signal. Under Loss of Signal (LOS) conditions, RCLK1 is derived from MCLK. |
| 34 | 40 | RPOS1 (Bipolar) | DO | Receive Positive and Negative Data - Port 1. In the Bipolar I/O mode, these pins are the data outputs from port 1. See RPOS0 and RNEG0 for signal descriptions. |
| 35 | 41 | RNEG1 (Bipolar) | DO | |
| 36 | 42 | TNEG1 (Bipolar) | DI | Transmit Positive and Negative Data - Port 1. In the Bipolar I/O mode, these pins are the positive and negative sides of a bipolar input pair for port 1. Data to be transmitted onto the twisted-pair line is input at these pins. |
| 37 | 43 | TPOS1 (Bipolar) | DI | |
| 38 | 44 | TCLK1 | DI | Transmit Clock - Port 1. 1.544 MHz for T1, 2.048 MHz for E1. The port 1 transmit data inputs are sampled on the falling edge of TCLK1. |
| 1. DI = Digital Input; DO = Digital Output; DI/O = Digital Input/Output; AI = Analog Input; AO = Analog Output; S = Power Supply. | | | | |

Table 2. Unipolar Host Mode Pin Descriptions¹

| Pin QFP | Pin PLCC | Symbol | I/O ² | Description |
|--|----------|--------|------------------|--|
| 41 | 3 | TDATA0 | DI | Transmit Data - Port 0. In the Unipolar I/O mode, the data to be transmitted onto the twisted-pair line from port 0 is input at this pin. |
| 42 | 4 | ECE0 | DI | Encoder Enable - Port 0. In the Unipolar I/O mode, a High on this pin enables the B8ZS or HDB3 encoder/decoder for port 0. |
| 43 | 5 | BPV0 | DO | Bipolar Violation - Port 0. In the Unipolar I/O mode, this pin goes High to indicate that a bipolar violation was detected at port 0. |
| 44 | 6 | RDATA0 | DO | Receive Data - Port 0. In the Unipolar I/O mode, RDATA0 is a Non Return-to-Zero (NRZ) output. CLKE determines the RCLK0 edge that RDATA0 is stable and valid. |
| 34 | 40 | RDATA1 | DO | Receive Data - Port 1. In the Unipolar I/O mode, RDATA1 is a Non Return-to-Zero (NRZ) output. CLKE determines the RCLK1 edge that RDATA1 is stable and valid. |
| 1. Table 1 describes the pins that do not change function in Unipolar Host mode and functions of pins unique to Bipolar mode. 2. DI = Digital Input; DO = Digital Output; DI/O = Digital Input/Output; AI = Analog Input; AO = Analog Output; S = Power Supply. | | | | |

Table 2. Unipolar Host Mode Pin Descriptions¹ (Continued)

| Pin QFP | Pin PLCC | Symbol | I/O ² | Description |
|---------|----------|--------|------------------|--|
| 35 | 41 | BPV1 | DO | Bipolar Violation - Port 1. In the Unipolar I/O mode, this pin goes High to indicate that a bipolar violation is detected at port 1. |
| 36 | 42 | ECE1 | DI | Encoder Enable - Port 1. In the Unipolar I/O mode, a High on this pin enables the B8ZS or HDB3 encoder/decoder for port 1. |
| 37 | 43 | TDATA1 | DI | Transmit Data - Port 1. In the Unipolar I/O mode, the data to be transmitted onto the twisted-pair line from port 1 is input at this pin. |

1. Table 1 describes the pins that do not change function in Unipolar Host mode and functions of pins unique to Bipolar mode.
 2. DI = Digital Input; DO = Digital Output; DI/O = Digital Input/Output; AI = Analog Input; AO = Analog Output; S = Power Supply.

Table 3. Hardware Mode and Bipolar Hardware Mode Pin Descriptions¹

| Pin QFP | Pin PLCC | Symbol | I/O ² | Description |
|---------|----------|-----------------|------------------|--|
| 39 | 1 | TRSTE | DI | Tristate Output Enable. When held High, forces all output pins to high-Z (tri-state). When held Low, Bipolar I/O mode is selected. In this mode, the framer interface is bipolar (TPOS/TNEG and RPOS/RNEG), and the B8ZS/HDB3 encoders are disabled. When clocked by MCLK, Unipolar I/O mode is selected. In this mode, the framer interface is unipolar (TDATA and RDATA), and the TNEG and RNEG pins are re-mapped. The TNEG pins are re-mapped as Encoder Enables (ECE) to individually enable the B8ZS/HDB3 encoder/decoder for each port. The RNEG pins are re-mapped as Bipolar Violation (BPV) indicators to report BPVs detected at the respective ports. |
| 40 | 2 | TCLK0 | DI | Transmit Clock - Port 0. 1.544 MHz for T1, 2.048 MHz for E1. The port 0 transmit data inputs are sampled on the falling edge of TCLK0. |
| 41 | 3 | TPOS0 (Bipolar) | DI | Transmit Data Positive and Negative - Port 0. In the Bipolar I/O mode, these pins are the positive and negative sides of a bipolar input pair for port 0. Data to be transmitted onto the port 0 twisted-pair line is input at these pins. |
| 42 | 4 | TNEG0 (Bipolar) | DI | |
| 43 | 5 | RNEG0 (Bipolar) | DO | Receive Data Positive and Negative - Port 0. In the Bipolar I/O mode, a signal on RNEG corresponds to receipt of a negative pulse on RTIP/RRING. A signal on RPOS corresponds to receipt of a positive pulse on RTIP/RRING. RNEG/RPOS outputs are Non Return-to-Zero (NRZ). RPOS and RNEG are stable and valid on the rising edge of RCLK. |
| 44 | 6 | RPOS0 (Bipolar) | DO | |
| 1 | 7 | RCLK0 | DO | Receive Clock - Port 0. Normally, this clock is recovered from the port 0 input signal. Under Loss of Signal (LOS) conditions, RCLK0 is derived from MCLK. |
| 2 | 8 | TAOS0 | DI | Transmit All Ones Enable - Port 0. When TAOS is High and RLOOP is Low, the TPOS/TNEG or TDATA input is ignored and the port transmits a stream of ones at the TCLK frequency. Refer to "Transmit All One's" on page 24 for details. |
| 3 | 9 | LEN20 | DI | Line Length Equalizer - Port 0. These pins determine the shape and amplitude of the port 0 transmit pulse. See Table 5 for details. |
| 4 | 10 | LEN10 | DI | |
| 5 | 11 | LEN00 | DI | |
| 6 | 12 | MCLK | DI | Master Clock. The master clock (1.544 MHz for T1, 2.048 MHz for E1) must be independent, free-running, continuously active and jitter free for receiver operation. Note that MCLK cannot be derived from RCLK because during a Loss of Signal (LOS) condition, transceiver timing is based on MCLK. |
| 7 | 13 | GND | S | Ground. Ground return for the VCC power supply. |

1. Table 1 describes the pins that do not change function in Unipolar Host mode and functions of pins unique to Bipolar mode.
 2. DI = Digital Input; DO = Digital Output; DI/O = Digital Input/Output; AI = Analog Input; AO = Analog Output; S = Power Supply.

Table 3. Hardware Mode and Bipolar Hardware Mode Pin Descriptions¹ (Continued)

| Pin QFP | Pin PLCC | Symbol | I/O ² | Description |
|----------------|----------------|-------------------------|------------------|---|
| 8 11 | 14 17 | TTIP0 TRING0 | AO AO | Transmit Tip and Ring - Port 0. These pins are differential driver outputs designed to drive a 35 - 200 Ω load. Line matching resistors and transformers can be selected to give the desired pulse height. See Figure 14 through Figure 16 . |
| 9 | 15 | TGND0 | S | Ground - Port 0 Transmit Driver. Ground return for the TVCC0 power supply. |
| 10 | 16 | TVCC0 | S | + 5 VDC - Port 0 Transmit Driver. TVCC0 must not vary from TVCC1 or VCC by more than ± 0.3 V. |
| 12 | 18 | DFM | DO | Driver Failure Monitor. This signal goes High to indicate a driver output short in one or both ports. |
| 13 | 19 | RLOOP0 | DI | Remote Loopback Enable - Port 0. When High, the clock and data inputs (from the framer) are ignored and the data received from the twisted-pair line is transmitted back onto the line at the RCLK frequency. Note that if LLOOP is High, Remote Loopback is inhibited (on the respective port). |
| 14 | 20 | LOS0 | DO | Loss of Signal - Port 0. Goes High to indicate that 175 consecutive spaces were detected. Returns Low when the received signal reaches a mark density of 12.5% (determined by receipt of four marks within a sliding 32-bit period, with no more than 15 consecutive zeros). Received marks are output on RPOS/RNEG or RDATA when LOS is High. |
| 15 16 | 21 22 | RTIP0 RRING0 | AI AI | Receive Tip and Ring - Port 0. These pins comprise the port 0 receive line interface and should be connected to the line through a center-tapped 1:2 transformer. See Figure 14 through Figure 16 for details. |
| 17 | 23 | LLOOP0 | DI | Local Loopback Enable - Port 0. When High, the RTIP/RRING inputs are disconnected and the transmit data inputs are routed back to the receive inputs (through the JA if enabled). Note that if RLOOP is High, Local Loopback is inhibited (on the respective port). |
| 18 19 | 24 25 | RRING1 RTIP1 | AI AI | Receive Tip and Ring - Port 1. These pins comprise the receive line interface and should be connected to the line through a center-tapped 1:2 transformer. See Figure 14 through Figure 16 for details. |
| 20 | 26 | LOS1 | DO | Loss of Signal - Port 1. Refer to LOS0 for signal description. |
| 21 | 27 | LLOOP1 | DI | Local Loopback Enable - Port 1. Refer to LLOOP0 for signal description. |
| 22 | 28 | TAOS1 | DI | Transmit All Ones Enable - Port 1. Refer to TAOS0 for signal description. |
| 23 26 | 29 32 | TRING1 TTIP1 | AO AO | Transmit Tip and Ring - Port 1. These pins are differential driver outputs designed to drive a 35 - 200 Ω load. Line matching resistors and transformers can be selected to give the desired pulse height. See Figure 14 through Figure 16 . |
| 24 | 30 | TVCC1 | S | + 5 VDC - Port 1 Transmit Driver. TVCC1 must not vary from TVCC0 or VCC by more than ± 0.3 V. |
| 25 | 31 | TGND1 | S | Ground - Port 1 Transmit Driver. Ground return for the TVCC1 power supply. |
| 27 | 33 | VCC | S | +5 VDC. Power supply for all circuits except the transmit drivers. |
| 28 | 34 | JASEL | DI | Jitter Attenuation Select - Port 0 and 1. When JASEL is High, the Jitter Attenuation (JA) circuits are placed in the receive paths. When JASEL is Low, the JA circuits are placed in the transmit paths. When JASEL is clocked with MCLK, the JA circuits are disabled. |
| 29 30 31 | 35 36 37 | LEN01 LEN11 LEN21 | DI DI DI | Line Length Equalizer - Port 1. These pins determine the shape and amplitude of the transmit pulse. See Table 5 for details. |
| 32 | 38 | RLOOP1 | DI | Remote Loopback Enable - Port 1. Refer to RLOOP0 for signal description. |

1. [Table 1](#) describes the pins that do not change function in Unipolar Host mode and functions of pins unique to Bipolar mode.
2. DI = Digital Input; DO = Digital Output; DI/O = Digital Input/Output; AI = Analog Input; AO = Analog Output; S = Power Supply.

Table 3. Hardware Mode and Bipolar Hardware Mode Pin Descriptions¹ (Continued)

| Pin QFP | Pin PLCC | Symbol | I/O ² | Description |
|---------|----------|-----------------|------------------|---|
| 33 | 39 | RCLK1 | DO | Receive Clock - Port 1. Normally, this clock is recovered from the port 1 twisted-pair input signal. Under Loss of Signal (LOS) conditions, RCLK1 is derived from MCLK. |
| 34 | 40 | RPOS1 (Bipolar) | DO | Receive Data Positive and Negative - Port 1. In the Bipolar I/O mode, these pins are the data outputs from port 1. See RPOS0 and RNEG0 for signal descriptions |
| 35 | 41 | RNEG1 (Bipolar) | DO | |
| 36 | 42 | TNEG1 (Bipolar) | DI | Transmit Data Positive and Negative - Port 1. In the Bipolar I/O mode, these pins are the positive and negative sides of a bipolar input pair for port 1. Data to be transmitted onto the port 1 twisted-pair line is input at these pins. |
| 37 | 43 | TPOS1 (Bipolar) | DI | |
| 38 | 44 | TCLK1 | DI | Transmit Clock - Port 1. 1.544 MHz for T1, 2.048 MHz for E1. The port 1 transmit data inputs are sampled on the falling edge of TCLK1. |

1. Table 1 describes the pins that do not change function in Unipolar Host mode and functions of pins unique to Bipolar mode.
2. DI = Digital Input; DO = Digital Output; DI/O = Digital Input/Output; AI = Analog Input; AO = Analog Output; S = Power Supply.

Table 4. Unipolar Hardware Mode Pin Descriptions¹

| Pin QFC | Pin PLCC | Symbol | I/O ² | Description |
|---------|----------|--------|------------------|--|
| 41 | 3 | TDATA0 | DI | Transmit Data - Port 0. In Unipolar I/O mode, the data to be transmitted onto the line from port 0 is input at this pin. |
| 42 | 4 | ECE0 | DI | Encoder Enable - Port 0. In Unipolar I/O mode, a High on this pin enables the B8ZS or HDB3 encoder/decoder for port 0. |
| 43 | 5 | BPV0 | DO | Bipolar Violation - Port 0. In Unipolar I/O mode, this pin goes High to indicate that a bipolar violation was detected at port 0. |
| 44 | 6 | RDATA0 | DO | Receive Data - Port 0. In Unipolar I/O mode, RDATA0 is a Non Return-to-Zero (NRZ) output. RDATA0 is stable and valid on the rising edge of RCLK0. |
| 34 | 40 | RDATA1 | DO | Receive Data - Port 1. In Unipolar I/O mode, RDATA1 is a Non Return-to-Zero (NRZ) output. RDATA1 is stable and valid on the rising edge of RCLK1. |
| 35 | 41 | BPV1 | DO | Bipolar Violation - Port 1. In Unipolar I/O mode, this pin goes High to indicate that a bipolar violation was detected on port 1. |
| 36 | 42 | ECE1 | DI | Encoder Enable - Port 1. In Unipolar I/O mode, a High on this pin enables the B8ZS or HDB3 encoder/decoder for port 1. |
| 37 | 43 | TDATA1 | DI | Transmit Data - Port 1. In Unipolar I/O mode, the data to be transmitted onto the line from port 1 is input at this pin. |

1. Table 3 describes the pins that do not change function in Unipolar Hardware mode and the functions of pins unique to Bipolar mode.
2. DI = Digital Input; DO = Digital Output; DI/O = Digital Input/Output; AI = Analog Input; AO = Analog Output; S = Power Supply

3.0 Functional Description

The figure on the front page of this Data Sheet shows a simplified block diagram of the LXT332. The LXT332 is a fully integrated Dual Line Interface Unit (DLIU) which contains two complete transceivers. The DLIU is designed for both 1.544 Mbps (DSX-1) and 2.048 Mbps (E1) applications. Both transceivers operate at the same frequency, which is determined by the MCLK input.

Each DLIU transceiver front end interfaces with two twisted-pair lines, one pair for transmit, one pair for receive. These two twisted-pair lines comprise a digital data loop for full duplex transmission. The integrated crystal-less jitter attenuator may be positioned in either the transmit or receive path, or disabled.

Each DLIU transceiver back-end interfaces with a framer through either bipolar or unipolar data I/O channels. The DLIU may be controlled by a microprocessor through the serial port (Host mode), or by hard-wired pins for stand-alone operation (Hardware mode).

3.1 Receiver

The two receivers in the LXT332 DLIU are identical. The following paragraphs describe the operation of one.

The twisted-pair input is received via a center-tapped 1:2 transformer. Positive pulses are received at RTIP, negative pulses at RRING. Recovered data is output at RPOS and RNEG in the bipolar mode and at RDATA in the unipolar mode. The recovered clock is output at RCLK. RPOS/RNEG or RDATA outputs are valid on the rising edge of RCLK. Refer to the Test Specifications Section for receiver timing.

The receive signal is processed through the peak detector and data slicers. The peak detector samples the received signal and determines its maximum value. A percentage of the peak value is provided to the data slicers as a threshold level to ensure optimum signal-to-noise ratio. For DSX-1 applications (line length inputs LEN0 - LEN2 \neq 000 or 001) the threshold is set to 70% (typical) of the peak value. This threshold is maintained above the specified level for up to 15 successive zeros over the range of specified operating conditions. For E1 applications (LEN inputs = 000 or 001), the threshold is 50% (typical).

The receiver is capable of accurately recovering signals with up to -13.6 dB of attenuation (from 2.4 V), corresponding to a received signal level of approximately 500 mV. Maximum line length is 1500 feet of ABAM cable (approximately 6 dB of attenuation). Regardless of received signal level, the peak detectors are held above a minimum level of 0.3 V (typical) to provide immunity from impulsive noise.

After processing through the data slicers, the received signal goes to the data and timing recovery section, and to the receive monitor. The data and timing recovery circuits provide an input jitter tolerance better than required by Pub 62411 or ITU G.823, as shown in Test Specifications.

The receiver monitor loads a digital counter at the RCLK frequency. The count is incremented each time a zero is received, and reset to zero each time a one (mark) is received. Upon receipt of 175 consecutive zeros the LOS flag is set, and the recovered clock is replaced by MCLK at the RCLK output in a smooth transition. (MCLK is required for receive operation.) When the received signal reaches 12.5% ones density (4 marks in a sliding 32-bit period) with no more than

15 consecutive zeros, the LOS flag is reset and another smooth transition replaces MCLK with the recovered clock at RCLK. During LOS conditions, received data is output on RPOS/RNEG (or RDATA if unipolar I/O is selected).

Depending on the options selected, recovered clock and data signals may be routed through the jitter attenuator, through the B8ZS/HDB3 decoder, and may be output to the framer as either bipolar or unipolar data. In unipolar data I/O mode, the LXT332 reports bipolar violations via an output for one RCLK period on the respective BPV pin.

3.2 Transmitter

The two transmitters in the LXT332 DLIU are identical. The following paragraphs describe the operation of a single transmitter.

Transmit data from the framer is clocked serially into the device at TPOS/TNEG in the bipolar mode or at TDATA in the unipolar mode. The transmit clock (TCLK) supplies the input synchronization. The transmitter samples TPOS/TNEG or TDATA inputs on the falling edge of TCLK. If TCLK is not supplied, the transmitter remains powered down and the TTIP/TRING outputs are held in a high-Z state, except during RLOOP, DLOOP, QRSS or TAOS modes. A separate power supply (TVCC0 or TVCC1) supplies each output driver. Current limiters on the output drivers provide short circuit protection. Refer to the Test Specifications Section for MCLK and TCLK timing characteristics. The LXT332 transmits data as a 50% Alternate Mark Inversion (AMI) line code as shown in Figure 4. Enabling the zero suppression encoders/decoders overrides the default and the transmission complies with the selected encoding scheme.

Figure 4. 50% AMI Coding

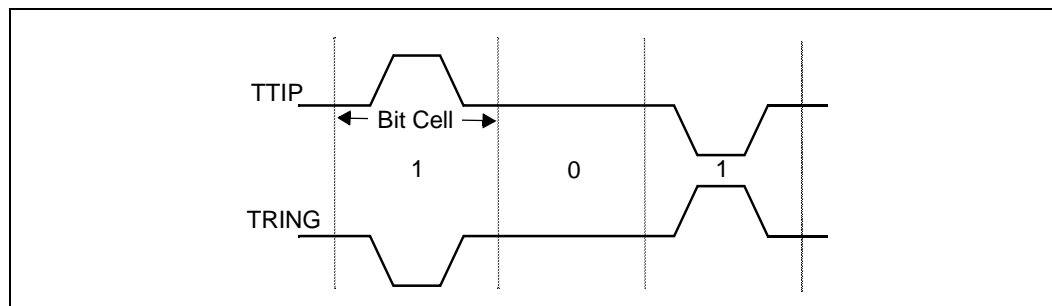

Zero suppression is available only in Unipolar mode. The two zero-suppression types are B8ZS, used in T1 environments, and HDB3, used in E1 environments. The scheme selected depends on whether the application is T1 or E1.

3.2.1 Bipolar Violation Insertions

In the Host mode with unipolar data I/O selected, a Bipolar Violation (BPV) insert function is available. When the VCQE pin is held High, VCQ0 and VCQ1 pins control bipolar violation insertion for ports 0 and 1, respectively. TDATA and VCQ are both sampled on the falling edge of TCLK. If VCQ is High, the next available mark is transmitted as a BPV, except as follows:

1. B8ZS and HDB3 zero suppression is not violated.
2. If Local Loopback (LLOOP) and Transmit All Ones (TAOS) are both active, the BPV is looped back to RDATA but the line driver transmits All Ones (no violations).

3. During Remote Loopback, BPV insertion is disabled.

A Low-to-High transition on VCQ is required for each subsequent BPV insertion.

3.2.2 Pulse Shape

The transmitted pulse shape is determined by Line Length equalizer control signals LEN0 through LEN2 as shown in Table 5. Equalizer codes are hardwired in Hardware mode. In Host mode the LEN codes are input through the serial interface. Shaped pulses are applied to the AMI line driver for transmission onto the line at TTIP and TRING. The line driver provides a constant low output impedance of less than 3Ω (typical), regardless of whether it is driving marks or spaces. This well controlled impedance provides excellent return loss when used with external precision resistors ($\pm 1\%$ accuracy) in series with the transformer. Table 9 lists recommended transformer specifications. Table 10 lists transmit transformer data, series resistor (R_t) values, and typical return losses for various LEN codes. To minimize power consumption the LXT332 can be tied directly to a 1:1.15 transformer without series resistors.

Pulses can be shaped for either 1.544 Mbps or 2.048 Mbps applications. 1.544 Mbps pulses for DSX-1 applications can be programmed to match line lengths from 0 to 655 feet of 22 AWG ABAM cable. A combination of 9.1Ω resistors and a 1:2.3 transformer is recommended for DSX-1 applications. The LXT332 also matches FCC pulse mask specifications for CSU applications.

Table 5. Equalizer Control Inputs

| LEN2 | LEN1 | LEN0 | Line Length ¹ | Cable Loss ² | Application | Transmit Rate |
|---|------|------|--------------------------|-------------------------|-----------------------------------|---------------|
| 0 | 1 | 1 | 0 – 133 ft. ABAM | 0.6 dB | DSX-1 | 1.544 Mbps |
| 1 | 0 | 0 | 133 – 266 ft. ABAM | 1.2 dB | | |
| 1 | 0 | 1 | 266 – 399 ft. ABAM | 1.8 dB | | |
| 1 | 1 | 0 | 399 – 533 ft. ABAM | 2.4 dB | | |
| 1 | 1 | 1 | 533 – 655 ft. ABAM | 3.0 dB | | |
| 0 | 0 | 0 | ITU Recommendation G.703 | | E1 – Coax (75Ω) | 2.048 Mbps |
| 0 | 0 | 1 | | | E1 – Twisted-pair (120Ω) | |
| 0 | 1 | 0 | FCC Part 68, Option A | | CSU | 1.544 Mbps |
| 1. Line length from LXT332 to DSX-1 cross-connect point 2. Maximum cable loss at 772 kHz | | | | | | |

The LXT332 produces 2.048 Mbps pulses for both 75Ω coaxial (2.37 V) or 120Ω shielded (3.0 V) lines through an output transformer with a 1:2 turns ratio. For coaxial systems, 9.1Ω series resistors are recommended. For twisted-pair lines, use 15Ω resistors.

3.3 Driver Failure Monitor

The transceiver incorporates an internal Driver Failure Monitor (DFM) in parallel with TTIP and TRING. A capacitor, charged via a measure of the driver output current and discharged by a measure of the maximum allowable current, detects driver failure. Shorted lines draw excess current, overcharging the capacitor. When the capacitor charge deviates outside the nominal charge window, a driver failure is reported. In Host mode the DFM bit is set in the serial word. In Hardware mode the DFM pin goes High. During a long string of spaces, a short-induced overcharge eventually bleeds off, clearing the DFM flag. The DFM feature will only detect short circuits when a very short cable is present at the output. Note that different cable lengths will change the short-circuit current substantially.

3.4 Jitter Attenuation

A digital Jitter Attenuation Loop (JAL) combined with an Elastic Store (ES) provides jitter attenuation. The JAL is internal and requires no external crystal nor high-frequency (higher than line rate) clock. When JASEL = 1, the JAL is placed in the receive path. When JASEL = 0, the JAL is placed in the transmit path. With JASEL clocked by MCLK, the JAL is disabled. MCLK is the reference for the JAL.

The ES is a 32 x 2-bit register. Data is clocked into the ES with the associated clock signal (TCLK or RCLK), and clocked out of the ES with the dejittered JAL clock. When the ES is within two bits of overflowing or underflowing, the ES adjusts the output clock by 1/8 of a bit period. The ES produces an average delay of 16 bits in the associated path.

Host mode provides a dejittered High Frequency Clock (HFC). This 8x clock (12.352 MHz for T1, 16.384 MHz for E1) is tied to the output clock from the JAL. With JA active in the receive path, HFC is tied to RCLK, and under LOS conditions, defaults to MCLK. With JA active in the transmit path, HFC is tied to TCLK, and defaults to MCLK if TCLK is not available. If the JA is disabled, HFC is tied to MCLK.

3.5 Built-In Self Test

In Host mode, the LXT332 provides for Built-In Self Test (BIST) applications. Quasi-Random Signal Source (QRSS) generation and detection circuitry is integrated into the LXT332. When the QRSS function is selected, the LXT332 detects and reports QRSS pattern sync on the incoming signal. When triggered, the LXT332 also transmits the QRSS pattern onto the line. Pattern transmission and detection is independently triggered and reported for each port. Refer to “Diagnostic Mode Operation” on page 24 for detailed description.

3.6 Operating Modes

The LXT332 transceiver operates in either stand-alone Hardware (default) mode or Host mode depending on the input to the SPE pin.

The data I/O mode (bipolar or unipolar) is controlled by the TRSTE pin. When TRSTE is Low, Bipolar I/O mode is selected. When TRSTE is clocked, Unipolar I/O is selected. Several diagnostic modes are available on command.

3.7 Host Mode Control

The LXT332 operates in the Host mode when the SPE pin is clocked with MCLK. In Host mode a microprocessor controls the LXT332 through the serial I/O port (SIO) which provides common access to both LIUs. Each of the two LIUs contains a pair of data registers, one for command inputs and one for status outputs. Only one LIU can be selected at a time. If both PS0 and PS1 are active, Port 0 has priority over Port 1. An SIO transaction is initiated by a falling pulse on one of the two Port Select pins, PS0 or PS1. A High-to-Low transition on PS0/1 is required for each subsequent access to the Host mode registers. If both PS0 and PS1 are active simultaneously, Port 0 has priority over Port 1.

The LIU, selected by the PS pulse, responds by writing the incoming serial word from the SDI pin into its command register. Figure 5 shows an SIO write operation. The 16-bit serial word consists of an 8-bit Command/Address byte and an 8-bit Data byte. If the command word contains a read request, the addressed LIU subsequently outputs the contents of its status register onto the SDO pin. Figure 6 shows an SIO read operation. The Clock Edge (CLKE) signal determines when the SDO and receive data outputs are valid, relative to the Serial Clock (SCLK) or RCLK as listed in Table 6. Refer to the Test Specifications section for SIO timing.

3.7.1 Serial Input Word

Figure 5 shows the Serial Input data structure. The LXT332 is addressed by setting bit A4 in the Address/Command byte, corresponding to address 16. Bit 1 of the serial Address/Command byte provides Read/Write (R/\overline{W}) control when the chip is accessed. The R/\overline{W} bit is set to logic 1 to read the data output byte from the chip, and set to logic 0 to write the input data byte to the chip.

The second 8 bits of a write operation, the Data Input byte, clear Loss of Signal (LOS) and Driver Fail Monitor (DFM) interrupts, reset the chip, and control diagnostic modes. The first 2 bits (D0 – D1) clear and/or mask LOS and DFM interrupts, and the last 3 bits (D5 – D7) control operating modes (normal and diagnostic) and chip reset. Refer to Table 7 for details on bits D5 – D7 of the Serial Input Word.

3.7.2 Serial Output Word

Figure 6 shows the Serial Output data structure. SDO is high impedance when SDI receives an Address/Command byte. If SDI receives a write command ($R/W = 0$), SDO remains in high impedance. If the command is a read ($R/W = 1$), then SDO becomes active after the last Command/Address bit (A6) and remains active for eight SCLK cycles. Typically the first bit out of SDO changes the state of SDO from high-z to a Low/High. This occurs approximately 100 ns after the eighth falling edge of SCLK.

The output data byte reports Loss of Signal (LOS) and Driver Fail Monitor (DFM) conditions, equalizer settings, and operating modes (normal or diagnostic). The first 5 bits (D0 - D4) report LOS and DFM status, and the Line Length Equalizer settings. The last 3 bits (D5 - D7) report operating modes and interrupt status.

If the \overline{INT}_x line for port x is High (no interrupt is pending), bits D5 - D7 report the operating modes listed in Table 8. If the \overline{INT}_x line for port x is Low, the interrupt status overrides all other reports and bits D5 - D7 reflect the interrupt status as listed in Table 8.

Table 6. CLKE Settings

| CLKE | Output | Clock | Valid Edge |
|------|-----------|-------|------------|
| LOW | RPOS/RNEG | RCLK | Rising |
| | RDATA | RCLK | Rising |
| | SDO | SCLK | Falling |
| HIGH | RPOS/RNEG | RCLK | Falling |
| | RDATA | RCLK | Falling |
| | SDO | SCLK | Rising |

Table 7. SIO Input Bit Settings (See Figure 5)

| Mode | RLOOP Bit D5 | LLOOP Bit D6 | TAOS Bit D7 |
|-------------------|-----------------|-----------------|----------------|
| Remote Loopback | 1 | 0 | x |
| Local Loopback | 0 | 1 | x |
| Dual loopback | 1 | 1 | 1 |
| Transmit all ones | 0 | x | 1 |
| Reset | 1 | 1 | 0 |

Table 8. LXT332 Serial Data Output Bit Coding (See Figure 6)

| Bit | | | Operating Modes |
|--|----|----|--|
| D5 | D6 | D7 | |
| 0 | 0 | 0 | Reset has occurred, or no program input (i.e., normal operation) or DLOOP active. ¹ |
| 0 | 0 | 1 | TAOS active |
| 0 | 1 | 0 | LLOOP active |
| 0 | 1 | 1 | TAOS and LLOOP active |
| 1 | 0 | 0 | RLOOP active |
| Interrupt Status | | | |
| 1 | 0 | 1 | DFM has changed state since last Clear DFM occurred |
| 1 | 1 | 0 | LOS has changed since last Clear LOS occurred |
| 1 | 1 | 1 | DFM and LOS have changed since last Clear DFM and Clear LOS occurred |
| 1. No explicit status information is available on DLOOP. | | | |

Figure 5. LXT332 SIO Write Operation

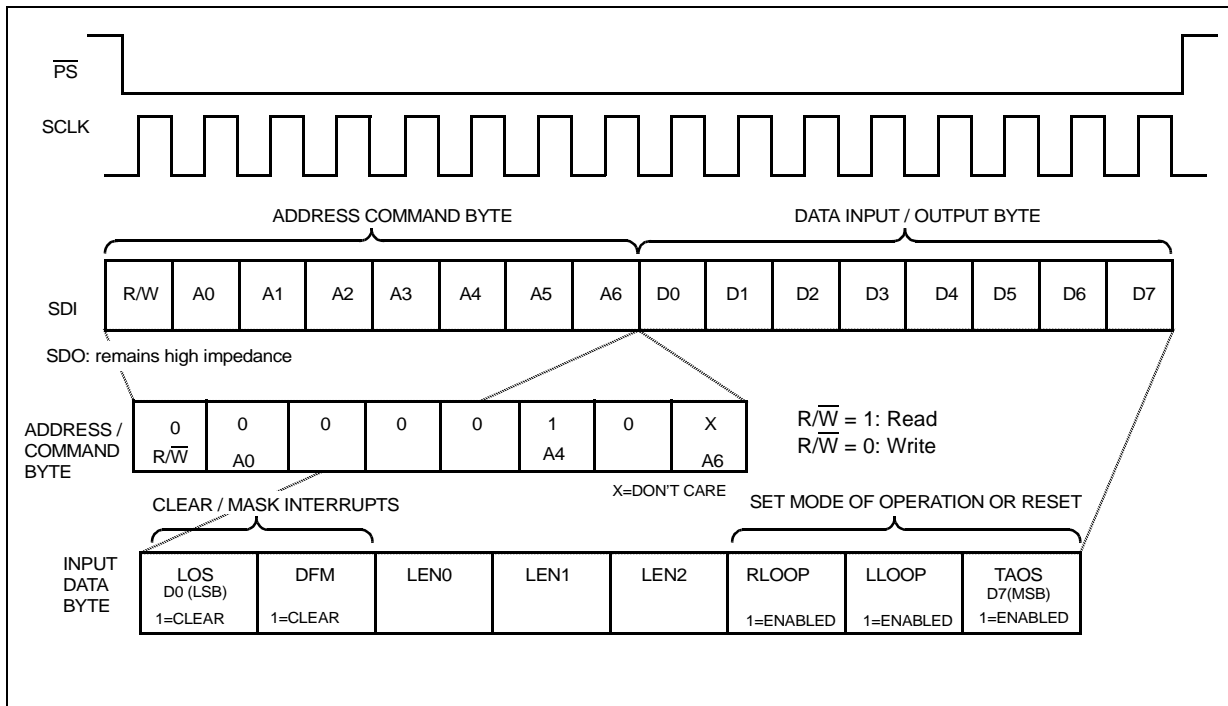

Figure 6. LXT332 SIO Read Operation

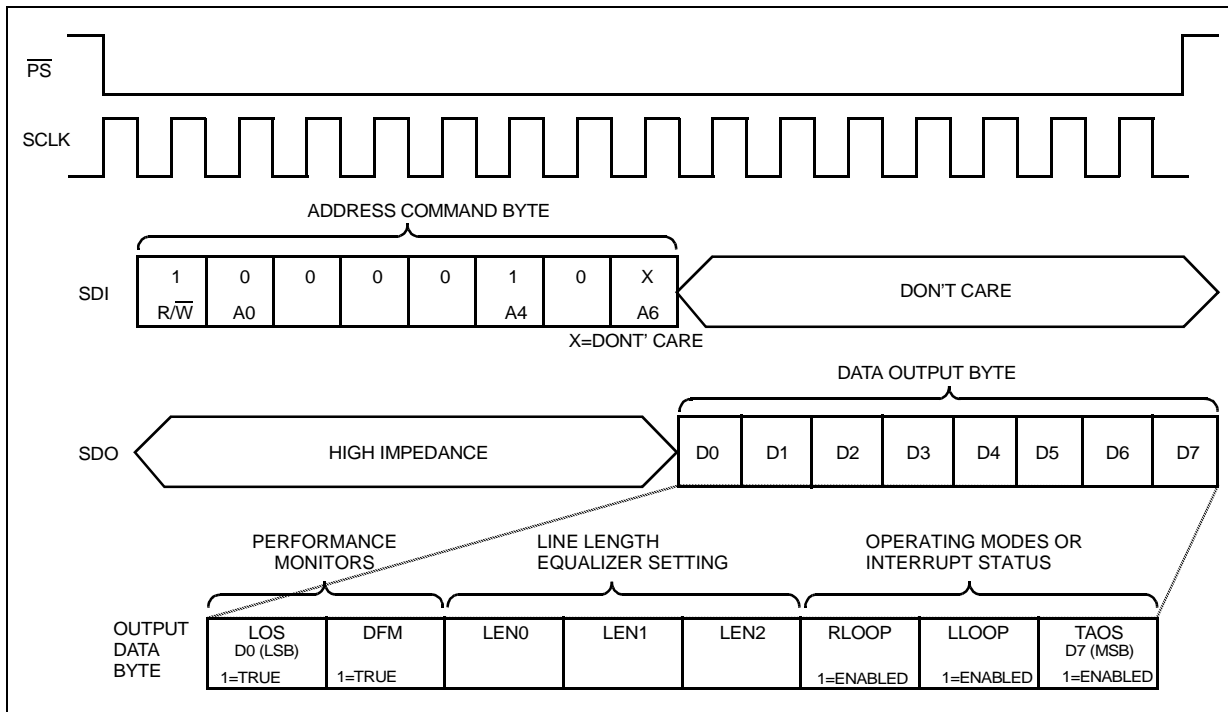
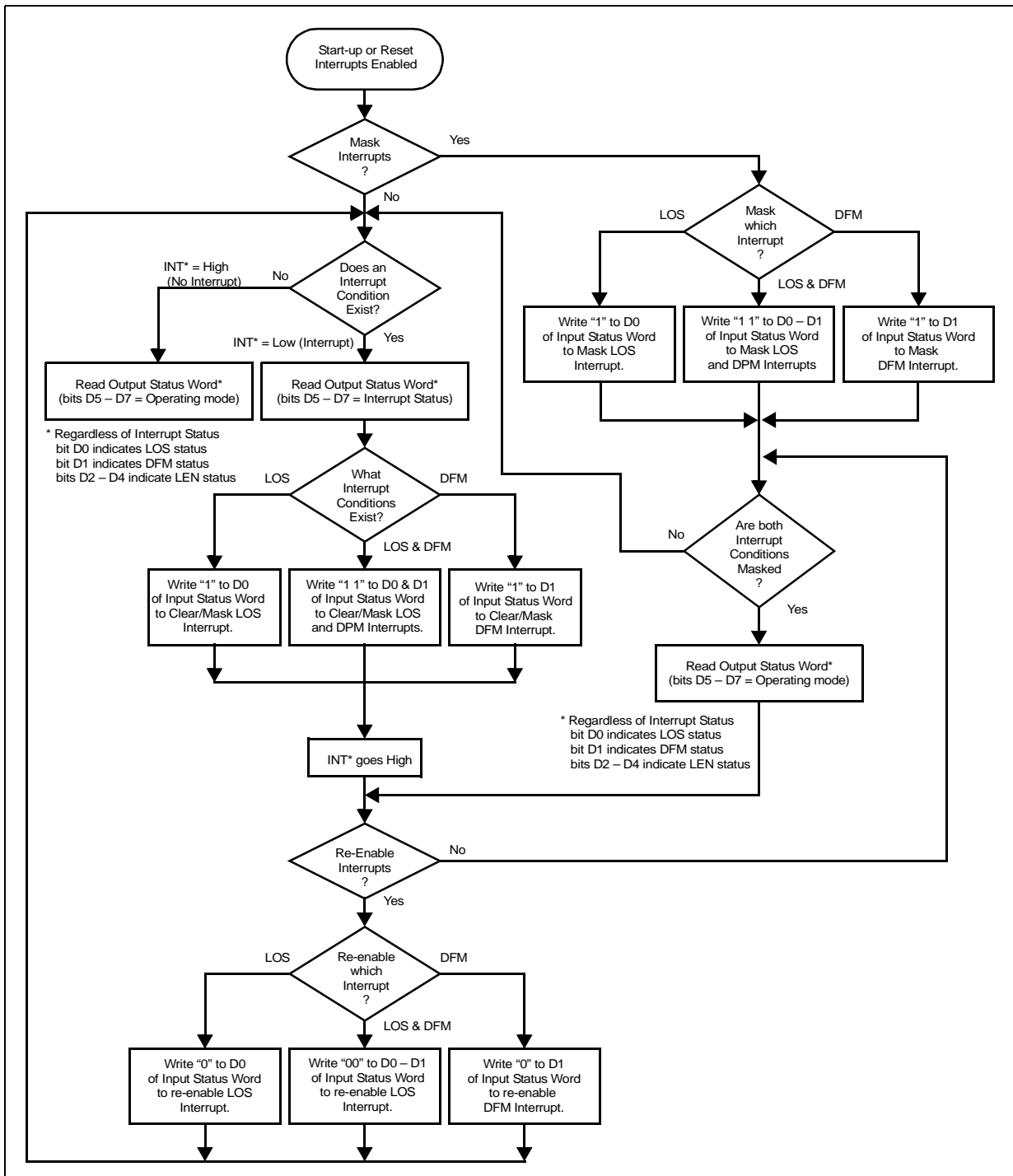

Figure 7. LX332 Interrupt Handling



3.7.3 Interrupt Handling

The Host mode provides two latched Interrupt output pins, INT0 and INT1, one for each LIU port. An interrupt is triggered by a change in the LOS or DFM bits (D0 and D1 of the output data byte, respectively). As shown in [Figure 7](#), either or both interrupt generators can be masked by writing a one to the respective bit of the input data byte (D0 = LOS, D1 = DFM). When an interrupt has occurred, the INTx output pin is pulled Low. The output stage of each INTx pin consists only of a pull-down device. Hence, an external pull-up resistor is required. The interrupt is cleared as follows:

1. If one or both interrupt bits (LOS or DFM, D0 and D1 of the output data byte) = 1, writing a 1 to the respective input bit (D0 or D1, respectively, of the input data byte) will clear the interrupt. Leaving a 1 in either of these bit positions will effectively mask the associated interrupt. To re-enable the interrupt capability, reset D0 and/or D1 to 0.
2. If neither LOS or DFM=1, the interrupt will be cleared by resetting the chip. To reset the chip, set data input bits D5 and D6 = 1, and D7 = 0.

3.8 Hardware Mode Control

Hardware control is the default operating mode. The LXT332 operates in Hardware mode unless the LEN11/SPE pin is clocked. In Hardware mode the transceiver is controlled through individual pins; a μ P is not required. The SIO pins are re-mapped to provide control functions. Data I/O mode selection is unaffected by the control mode. The TRSTE pin selects either unipolar or bipolar data I/O. In Hardware mode the RPOS/RNEG or RDATA/BPV outputs are valid on the rising edge of RCLK.

3.9 Diagnostic Mode Operation

The LXT332 offers multiple diagnostic modes. Local Loopback (LLOOP), Remote Loopback (RLOOP), Dual Loopback (DLOOP) and Transmit All Ones (TAOS) are available under both Host and Hardware control. An additional Quasi-Random Signal Source (QRSS) mode is available under Host control only.

In Host mode, diagnostic modes are selected by writing the appropriate SIO bits. In Hardware mode, diagnostic modes are selected by a combination of pin settings. The pins must be held at the specified levels for a minimum of 20 ns. The SIO bit names (Host mode) and pin identifiers (Hardware mode) for diagnostic functions are identical. Where a particular function can be enabled in either mode, 1 = High and 0 = Low.

3.9.1 Transmit All Ones (See [Figure 8](#))

Transmit All Ones (TAOS) is selected when TAOS = 1 and RLOOP = 0. In TAOS mode the TPOS and TNEG inputs are ignored. The TAOS reference clock is determined by setting the jitter attenuator. When jitter attenuation is set for the transmit side, MCLK is used as the TAOS reference clock and TCLK is the fall back clock. When JA is set for the receive side, TCLK is the TAOS reference clock and MCLK is the fall back clock. When JA is inactive, MCLK is the TAOS reference clock and TCLK is the fall back. TAOS can be commanded simultaneously with Local Loopback as shown in [Figure 9](#), but is inhibited during Remote and Dual Loopback.

Figure 8. TAOS Data Path

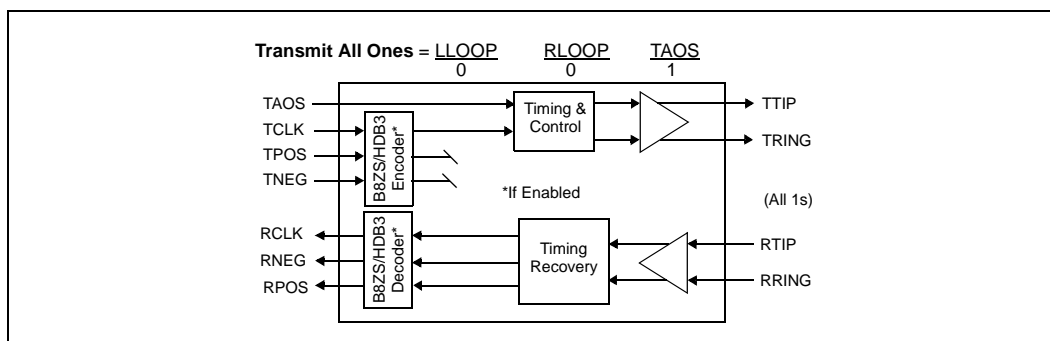

3.9.2 Local Loopback (See Figure 9 and Figure 10)

Local Loopback (LLOOP) is selected when LLOOP = 1 and RLOOP = 0. In LLOOP mode, the receiver circuits are inhibited. The transmit clock and data inputs (TCLK and TPOS/TNEG or TDATA) are looped back and output at RCLK and RPOS/RNEG or RDATA. During Local Loopback, the JASEL input functions as follows: If JASEL=0, JA is enabled and active in both the Transmit path and the loopback circuit. If JASEL=1, JA is enabled in the Loopback circuit only. If JASEL = MCLK, JA is disabled.

The transmitter circuits are unaffected by LLOOP. The TPOS/TNEG or TDATA inputs (or a stream of 1s if the TAOS command is active) will be transmitted normally. When used in this mode, the transceiver can be used as a stand-alone jitter attenuator.

Figure 9. TAOS with LLOOP & Selectable JA

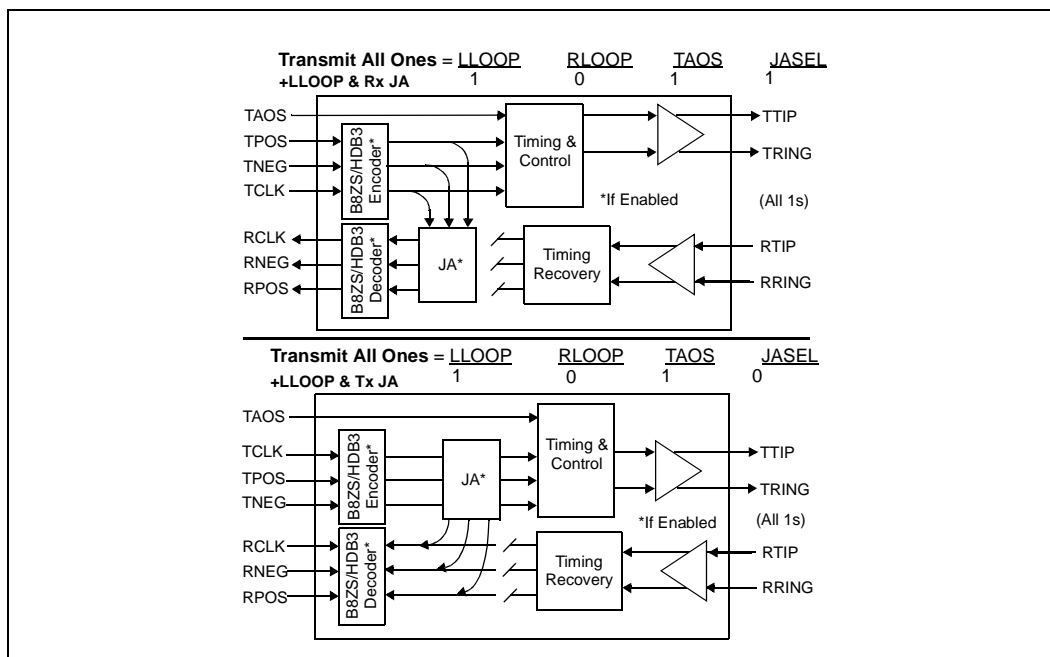
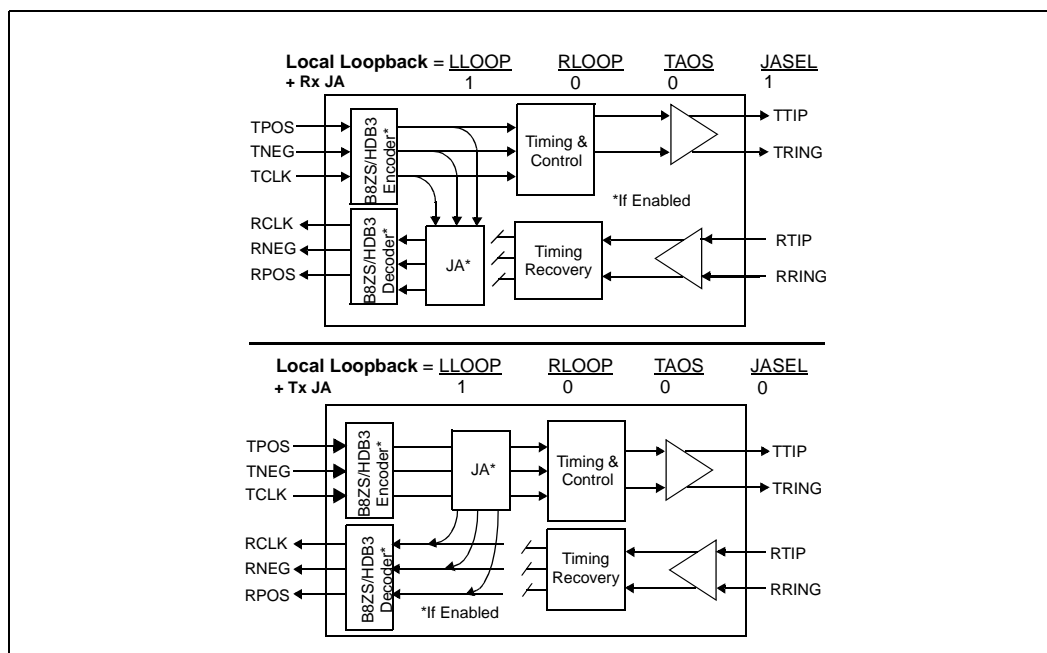

Figure 10. Local Loopback - Selectable JA



3.9.3 Remote Loopback (See Figure 11)

Remote Loopback (RLOOP) is selected when $\text{RLOOP} = 1$ and $\text{LLOOP} = 0$. Note that TAOS cannot be commanded when Remote Loopback is selected. In RLOOP mode, the transmit clock and data inputs (TCLK and TPOS/TNEG or TDATA) are ignored. The RPOS/RNEG or RDATA outputs are looped back to the transmit circuits and output on TTIP and TRING at the RCLK frequency. Receiver circuits are unaffected by the RLOOP command and continue to output the data and clock signals received from the line. During Remote Loopback, the JASEL input functions as follows: If $\text{JASEL} = 1$, JA is enabled and active in both the Receive path and the loopback circuit. If $\text{JASEL} = 0$, JA is enabled in the Loopback circuit only. If $\text{JASEL} = \text{MCLK}$, JA is disabled.

Figure 11. Remote Loopback - Selectable JA

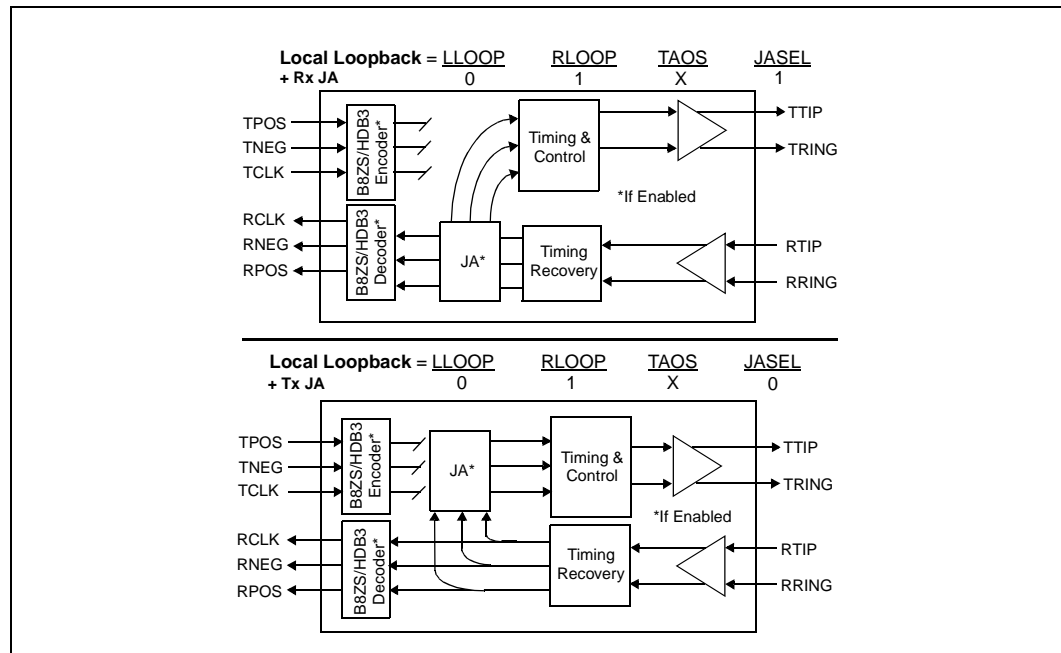

3.9.4 Dual Loopback (See Figure 12)

Dual Loopback (DLOOP) is selected when RLOOP = 1, LLOOP = 1 and TAOS = 1. In DLOOP mode, the transmit clock and data inputs (TCLK and TPOS/TNEG or TDATA) are looped back through the jitter attenuator (unless disabled by a clock input to the JASEL pin) and output at RCLK and RPOS/RNEG or RDATA. The data and clock recovered from the line are looped back through the transmit circuits and output on TTIP and TRING without jitter attenuation. Unlike the other diagnostic modes, no explicit SIO status indicator is available for DLOOP in the SIO status register.

Figure 12. Dual Loopback

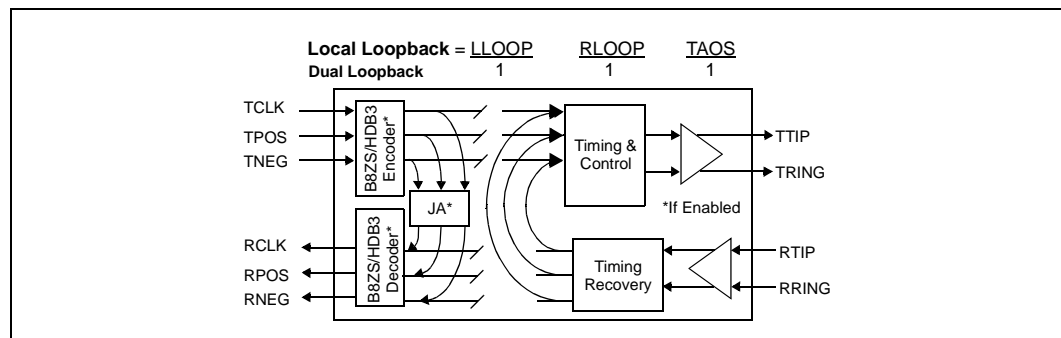

3.9.5 QRSS Built-In Self Test - Host Mode

The QRSS Built-In Self Test (BIST) is available only under Host control. As shown in Figure 13, the QRSS BIST function is selected by clocking the VCQE pin with MCLK. Once the QRSS BIST function is selected, the VCQ0 and VCQ1 pins are re-mapped to trigger the QRSS transmission. A

High on one of these pins triggers QRSS pattern transmission from the appropriate port. The QRSS pattern for DSX-1 systems is $2^{20} - 1$, with no more than 14 consecutive zeros. For CEPT systems the QRSS pattern is $2^{15} - 1$. The QRSS pattern is locked to MCLK. Once the QRSS transmission is activated, errors can be inserted into the transmit data stream by causing a Low-to-High transition on the TPOS/TDATA pin for the respective port.

In Bipolar I/O mode, Low-High transitions cause both a logic error and a bipolar violation to be inserted into the QRSS data stream. In Unipolar I/O mode, only a logic error is inserted.

The Pattern Detect circuitry is activated by the QRSS BIST function, although the basic receive circuits are unaffected. The Pattern Detect pins (PD0 and PD1) indicate QRSS pattern sync for the respective LIU port. The PD pin stays High until synchronization is achieved on the QRSS pattern. The QRSS pattern is considered in sync when there are fewer than 4 errors in 128 bits. The PD pin goes High indicating an out-of-sync condition if 4 or more errors are detected in 128 bits (i.e. sync is defined as fewer than 4 errors in 128 bits).

Figure 13. QRSS BIST

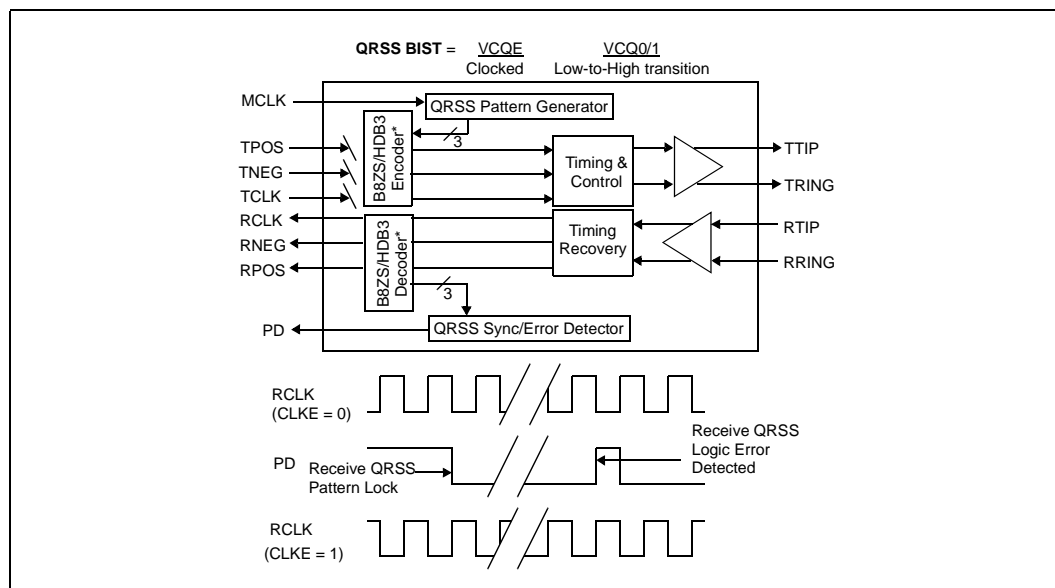

3.10 Initialization/Reset Operation

Upon initial power up, the transceiver is held static until the power supply reaches approximately 3 V. Upon crossing this threshold, the device clears all internal registers and begins calibration of the delay lines. A reference clock is required to calibrate the delay lines. TCLK is the transmit reference, and MCLK is the receive reference. The PLLs are continuously calibrated.

The transceiver can be reset from either the Host or Hardware mode. In Host mode, reset is commanded by writing 1s to RLOOP and LLOOP, and a 0 to TAOS (bits D5, D6 and D7, respectively, of the SIO input data byte). In Hardware mode, reset is commanded by simultaneously holding RLOOP and LLOOP High, and TAOS Low, for approximately 200 ns. Reset is initiated on the falling edge of the reset request. In either mode, each port may be reset independently. Reset clears and sets all SIO registers, of the selected port, to 0. Reset is not generally required for the port to be operational.

4.0 Application Information

4.1 Power Requirements

The LXT332 is a low-power CMOS device. It operates from a single +5 V power supply which can be tied to all three VCC pins. However, all inputs must be within ± 0.3 V of each other, and decoupled to their respective grounds separately. Isolation between the transmit and receive circuits is provided internally. During normal operation or local loopback, the transmitter powers down if TCLK is not supplied.

4.2 Transformers

The transformer specifications listed in [Table 9](#) provide the correct impedance matching for balanced transmit or receive lines. [Table 10](#) shows the combinations of resistors and transformers to produce a variety of return loss values depending on the LEN code settings chosen for a specific design.

4.3 Line Protection

On the receive side, the 1 k Ω series resistors protect the receiver against current surges coupled into the device. Due to the high receiver impedance (40 k Ω typical) the resistors do not affect the receiver sensitivity.

On the transmit side, the Schottky diodes D1-D4 protect the output driver. While not mandatory for normal operation, these protection elements are strongly recommended to improve the design's robustness.

4.4 1.544 Mbps T1 Applications

[Figure 14](#) shows a typical T1 Host mode application. The serial interface pins are grouped at the top. Host mode is selected by applying clock to SPE. Other mode selection pins are shown at the bottom. With the TRSTE pin switched Low, the LXT332 operates in the bipolar I/O mode. Driving JASEL Low switches the jitter attenuation circuits into the transmit paths for both LIU ports.

[Figure 14](#) shows a pair of framers (a dual framer could also be used). A LXP600A Clock Adapter (CLAD) converts the 2.048 MHz backplane clock to provide the 1.544 MHz input to the MCLK and TCLK inputs of both LIU ports.

The DFM and PD indicators and high frequency clocks are grouped at the lower left. These outputs are available to drive optional external circuits. The transmit driver power supply pins (TVCC0 and TVCC1) are tied to a common bus with 68 μ F decoupling capacitors installed. The power supply for the remaining (non-driver) circuitry (VCC) uses 1.0 μ F and 0.1 μ F decoupling capacitors.

The line interface circuitry is identical for both LIU ports. The precision resistors in line with the transmit transformer provide optimal return loss. The recommended transformer/resistor combinations are listed in Table 10. Center tapped 2:1 transformers are used on the receive side.

Table 9. Recommended Transformer Values

| Parameter | Value |
|--------------------------|--------------------------|
| Turns Ratio (T1) | 1:2.3 (Tx) / 1:2 CT (Rx) |
| Turns Ratio (E1) | 1:2 (Tx) / 1:2 CT (Rx) |
| Primary Inductance | 1.2 mH minimum |
| Leakage Inductance | 0.5 μ H maximum |
| Interwinding Capacitance | 25 pF maximum |
| DC Resistance (Pri.) | 1 Ω maximum |
| ET (Breakdown Voltage) | 1 kV minimum |

Table 10. Transformer Combinations

| LEN | Xfmr Ratio ¹ | Rt Value ² | Rtn Loss ³ |
|--|-------------------------|-----------------------|-----------------------|
| For T1/DSX-1 100 Ω Twisted-Pair Applications: | | | |
| 011 - 111 | 1:2 | Rt = 9.1 Ω | 14 dB |
| 011 - 111 | 1:2.3 | Rt = 9.1 Ω | 18 dB |
| 011 - 111 | 1:1.15 | Rt = 0 Ω | 1 dB |
| For E1 120 Ω Twisted-Pair Applications: | | | |
| 001 | 1:2 | Rt = 15 Ω | 18 dB |
| 000 | 1:2 | Rt = 9.1 Ω | 10 dB |
| For E1 75 Ω Coaxial Applications: | | | |
| 001 | 1:2 | Rt = 14.3 Ω | 10 dB |
| 000 | 1:2 | Rt = 9.1 Ω | 18 dB |
| 1. Transformer turns ratio accuracy is $\pm 2\%$. 2. Rt values are $\pm 1\%$. 3. Typical return loss, 51 kHz – 3.072 MHz, with a capacitor in parallel with the primary side of the transformer. | | | |

Figure 14. Typical LXT332 T1 Application (Host Control Mode, Bipolar I/O)

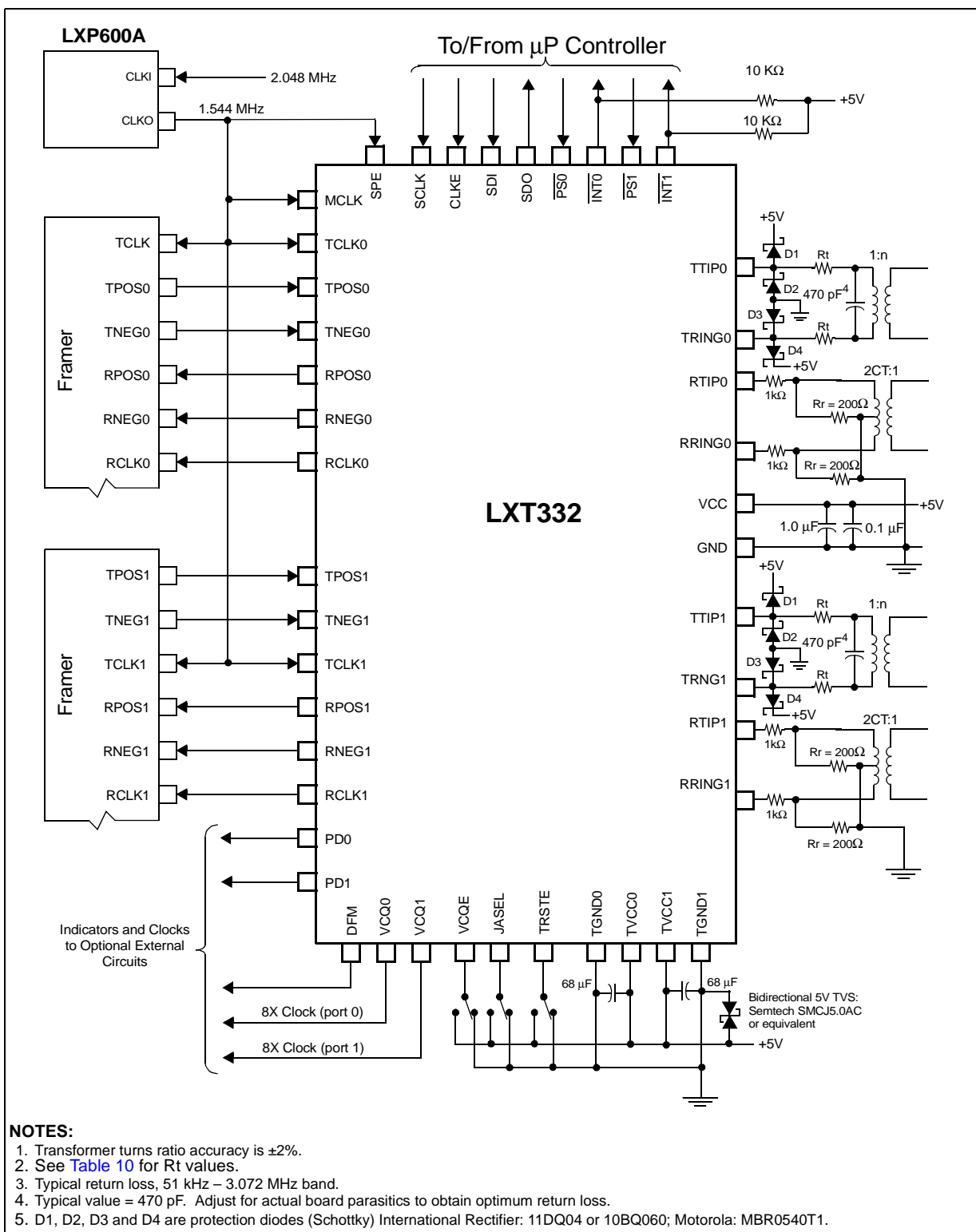

4.5 2.048 Mbps E1/CEPT Interface Applications

4.5.1 E1 Coaxial Applications

Figure 15 shows the line interface for a typical 2.048 Mbps E1 coaxial (75Ω) application. The LEN code should be set to 000 for coax. With 9.1Ω R_t resistors in line with the 1:2 output transformers, the LXT332 produces 2.37 V peak pulses as required for coax applications. As in the T1 application shown in Figure 14, center tapped 1:2 transformers are used on the receive side.

4.5.2 E1 Twisted-Pair Applications

Figure 16 shows a typical 2.048 Mbps E1 twisted-pair (120Ω) application. With the TRSTE pin tied to ground, the LXT332 operates in the bipolar data I/O mode. The JA circuit is placed in the transmit path by the Low on JASEL. The line length equalizers are controlled by the hardwired LEN inputs. With the LEN code set to 001 and 15Ω R_t resistors in line with the 1:2 output transformers, the LXT332 produces the 3.0 V peak pulses required for this application. Center tapped 1:2 transformers are used on the receive side.

A single clock source provides the 2.048 MHz input to MCLK and TCLK. The DFM pin may be routed to an LED driver or other indicator, or it may be left unconnected. Switches on the TAOS, LLOOP and RLOOP inputs provide mode control and hardware reset capability.

The transmit driver power supply pins (TVCC0 and TVCC1) are tied to a common bus with $68\mu\text{F}$ decoupling capacitors. The power supply for the remaining (non-driver) circuitry (VCC) uses $1.0\mu\text{F}$ and $0.1\mu\text{F}$ decoupling capacitors.

Figure 15. Line Interface for E1 Coax Applications

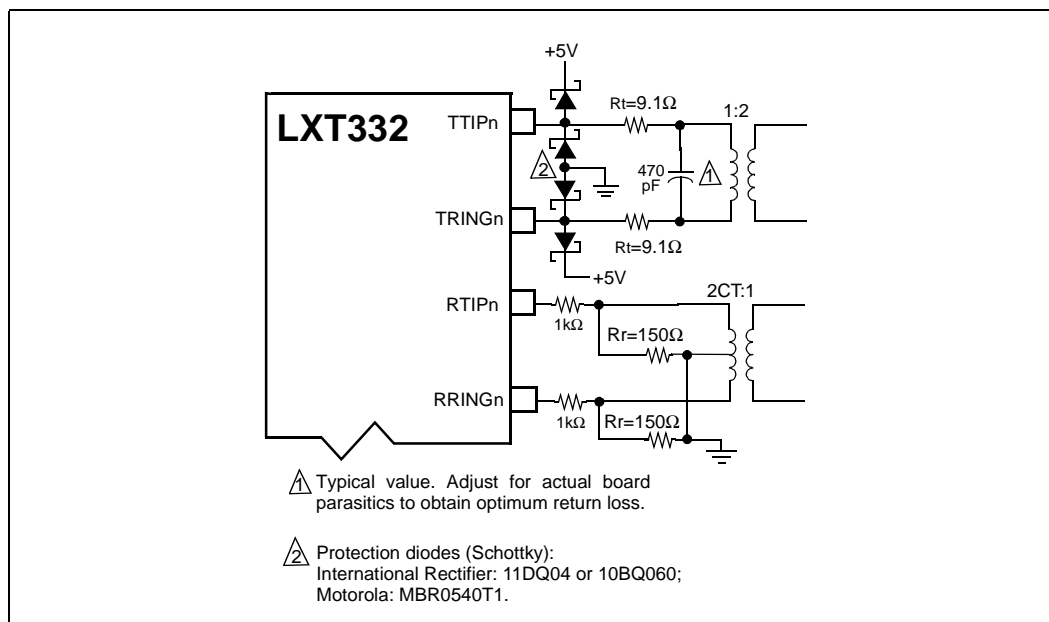
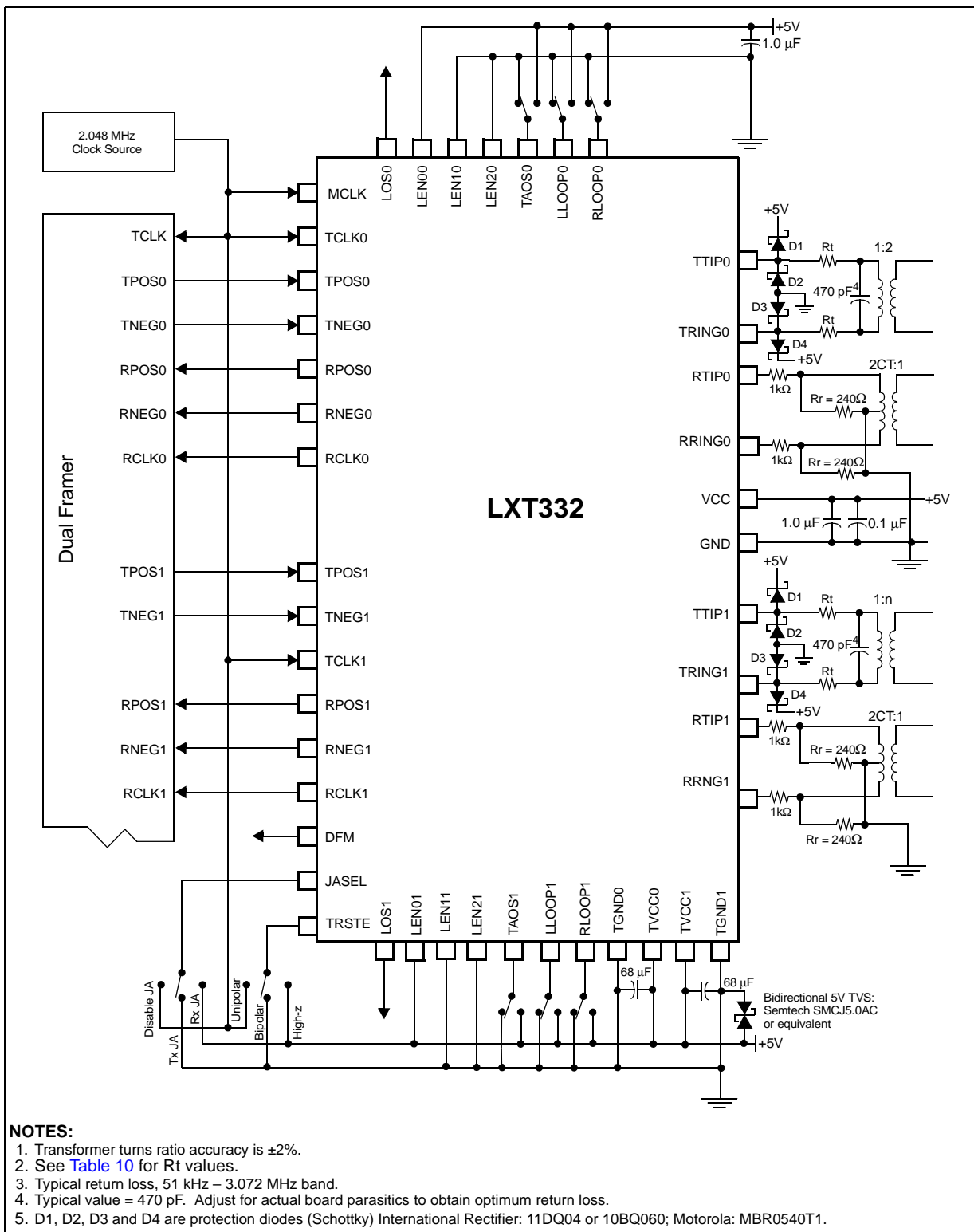

Figure 16. Typical LXT332 E1 120 Ω Application (Hardware Control Mode)



5.0 Test Specifications

Note: Information in Table 11 through Table 17 and Figure 17 through Figure 22 represent the performance specifications of the LXT332 Dual Line Interface Unit and are guaranteed by test, except as noted, by design.

Table 11. Absolute Maximum Ratings

| Parameter | Symbol | Minimum | Maximum | Units |
|-------------------------------------|-------------------|-----------|-----------------------|-------|
| DC supply (referenced to GND) | VCC, TVCC0, TVCC1 | – | 6.0 | V |
| Input voltage, any pin ¹ | V _{IN} | GND - 0.3 | V _{CC} + 0.3 | V |
| Input current, any pin ² | I _{IN} | -10 | 10 | mA |
| Storage temperature | T _{STG} | -65 | +150 | °C |

Caution: Operations at or beyond these limits may result in damage to the device.
Normal operation not guaranteed at these extremes.

- Excluding RTIP and RRING which must stay between -6 V and V_{CC} + 0.3 V.
- Transient currents of up to 100 mA will not cause SCR latch-up. TTIP, TRING, TV+, and TGND can withstand continuous current of 100 mA.

Table 12. Recommended Operating Conditions

| Parameter | Symbol | Minimum | Typical | Maximum | Units |
|-------------------------------|-------------------|---------|---------|---------|-------|
| DC supply ¹ | VCC, TVCC0, TVCC1 | 4.75 | 5.0 | 5.25 | V |
| Ambient operating temperature | T _A | -40 | 25 | 85 | °C |

1. Variation between TVCC0, TVCC1 and VCC must be within ±0.3 V of each other during steady state and transient conditions.

Table 13. Electrical Characteristics (Over Recommended Operating Conditions)

| Parameter | Sym | Min | Typ | Max | Units | Test Conditions |
|--|-----------------|-----|-----|-----|-------|----------------------------|
| Total power dissipation – T1 ¹ (Maximum line length) | P _d | – | 700 | 900 | mW | 100% ones density |
| | P _d | – | 550 | 700 | mW | 50% ones density |
| Total power dissipation – E1 ¹ | P _d | – | 575 | 700 | mW | 100% ones density |
| | P _d | – | 490 | 600 | mW | 50% ones density |
| High level input voltage ^{2,3} | V _{IH} | 2.0 | – | – | V | |
| Low level input voltage ^{2,3} | V _{IL} | – | – | 0.8 | V | |
| High level output voltage ^{2,3} | V _{OH} | 2.4 | – | – | V | I _{OUT} = -400 μA |
| Low level output voltage ^{2,3} | V _{OL} | – | – | 0.4 | V | I _{OUT} = 1.6 mA |
| Input leakage current ⁴ | I _{II} | 0 | – | ±10 | μA | |

- Total power dissipation includes the device power consumption and load power dissipation while driving a 75 Ω load on the secondary side. The T1 test circuit is a 100 Ω line load connected to the driver outputs via a 1:1.15 turns ratio transformer without series resistors.
- Functionality of pins depends on mode.
- Output drivers will output CMOS logic levels into CMOS loads.
- Except for MCLK, RTIP0, RRING0, RTIP1, and RRING1.
- Applies to QFP pins 8, 11, 23 & 26; PLCC pins 14, 17, 29 & 32

Table 13. Electrical Characteristics (Over Recommended Operating Conditions) (Continued)

| Parameter | Sym | Min | Typ | Max | Units | Test Conditions |
|---|-----|-----|-----|-----|-------|-----------------------------------|
| Three-state leakage current ² | Isl | 0 | – | ±10 | μA | |
| Input pull down current (MCLK) ⁵ | | | – | 100 | μA | |
| TTIP/TRING leakage current | Itr | – | – | 1.2 | mA | In tri-state and power down modes |

1. Total power dissipation includes the device power consumption and load power dissipation while driving a 75 Ω load on the secondary side. The T1 test circuit is a 100 Ω line load connected to the driver outputs via a 1:1.15 turns ratio transformer without series resistors.
2. Functionality of pins depends on mode.
3. Output drivers will output CMOS logic levels into CMOS loads.
4. Except for MCLK, RTIP0, RRING0, RTIP1, and RRING1.
5. Applies to QFP pins 8, 11, 23 & 26; PLCC pins 14, 17, 29 & 32

Table 14. Analog Specifications (Over Recommended Operating Conditions)

| Parameter | Min | Typ | Max | Units | Test Conditions | |
|---|------------------------------|------|-------|-------|-----------------|--|
| AMI output pulse amplitudes | DSX-1 | 2.4 | 3.0 | 3.6 | V | measured at the DSX |
| | E1 (120 Ω) | 2.7 | 3.0 | 3.3 | V | measured at line side |
| | E1 (75 Ω) | 2.13 | 2.37 | 2.61 | V | measured at line side |
| Transmit amplitude variation with supply ³ | – | 1 | 2.5 | % | | |
| Recommended output load at TTIP and TRING | – | 75 | – | Ω | | |
| Driver output impedance ³ | – | 3 | 10 | Ω | @ 772 kHz | |
| Jitter added by the transmitter ¹ | 10 Hz - 8 kHz ³ | – | 0.005 | 0.01 | UI | T1 Jitter based |
| | 8 kHz - 40 kHz ³ | – | 0.015 | 0.025 | UI | |
| | 10 Hz - 40 kHz ³ | – | 0.02 | 0.025 | UI | |
| | Broad Band | – | 0.03 | 0.05 | UI | |
| Jitter added by the transmitter ¹ | 20 Hz – 100 kHz | – | – | 0.05 | UI | E1 Jitter Band |
| Output power levels ³ | @772 kHz | 12.6 | – | 17.9 | dBm | |
| | DS1 2 kHz BW @ 1544 kHz | -29 | – | – | dB | referenced to power in 2 kHz band at 772 kHz |
| Positive to negative pulse imbalance | – | – | 0.5 | dB | | |
| Receive input impedance | – | 40 | – | kΩ | | |
| Sensitivity below DSX | (0 dB = 2.4 V) | 13.6 | – | – | dB | |
| | (max 6 dB cable attenuation) | 500 | – | – | mV | |
| Loss of signal threshold | – | 0.3 | – | V | | |
| Data decision threshold | DSX-1 | 60 | 70 | 77 | % peak | |
| | E1 | 43 | 50 | 57 | % peak | |
| Input jitter tolerance | 10 Hz | – | 1200 | – | UI | |
| | 750 Hz | 14 | – | – | UI | |
| | 10 kHz – 100 kHz | 0.4 | – | – | UI | |

1. Input signal to TCLK is jitter-free.
2. Circuit attenuates jitter at 20 dB/decade above the corner frequency.
3. Not production tested, but guaranteed by design and other correlation models.

Table 14. Analog Specifications (Over Recommended Operating Conditions) (Continued)

| Parameter | | Min | Typ | Max | Units | Test Conditions |
|--|----|-----|-----|-----|-------|-----------------|
| Allowable consecutive zeros before LOS | | 160 | 175 | 190 | – | |
| Jitter attenuation curve corner frequency ^{2,3} | T1 | – | 6 | – | Hz | |
| | E1 | – | 10 | – | Hz | |
| Attenuation input jitter tolerance before FIFO overflow ³ | | 28 | – | – | UI | |
| Jitter attenuation @ 10 kHz | | | 45 | – | dB | |

1. Input signal to TCLK is jitter-free.
 2. Circuit attenuates jitter at 20 dB/decade above the corner frequency.
 3. Not production tested, but guaranteed by design and other correlation models.

Table 15. LXT332 Serial I/O Timing Characteristics (See Figure 17 and Figure 18)

| Parameter | Sym | Min | Typ ¹ | Max | Units | Test Conditions |
|---|---------------------------------|-----|------------------|-----|-------|--------------------|
| Rise/Fall time - any digital output | t _{RF} | – | – | 100 | ns | Load 1.6 mA, 50 pF |
| SDI to SCLK setup time | t _{DC} | 50 | – | – | ns | |
| SCLK to SDI hold time | t _{CDH} | 50 | – | – | ns | |
| SCLK Low time | t _{CL} | 240 | – | – | ns | |
| SCLK High time | t _{CH} | 240 | – | – | ns | |
| SCLK rise and fall time | t _R , t _F | – | – | 50 | ns | |
| PS to SCLK setup time | t _{PC} | 50 | – | – | ns | |
| SCLK to PS hold time | t _{CPH} | 50 | – | – | ns | |
| PS inactive time | t _{PWH} | 250 | – | – | ns | |
| SCLK to SDO valid | t _{CDV} | – | – | 200 | ns | |
| SCLK falling edge or PS rising edge to SDO high-z | t _{CDZ} | – | 100 | – | ns | |

1. Typical figures are at 25 °C and are design aid only; not guaranteed and not subject to production testing.

Figure 17. LXT332 Serial Data Input Timing Diagram

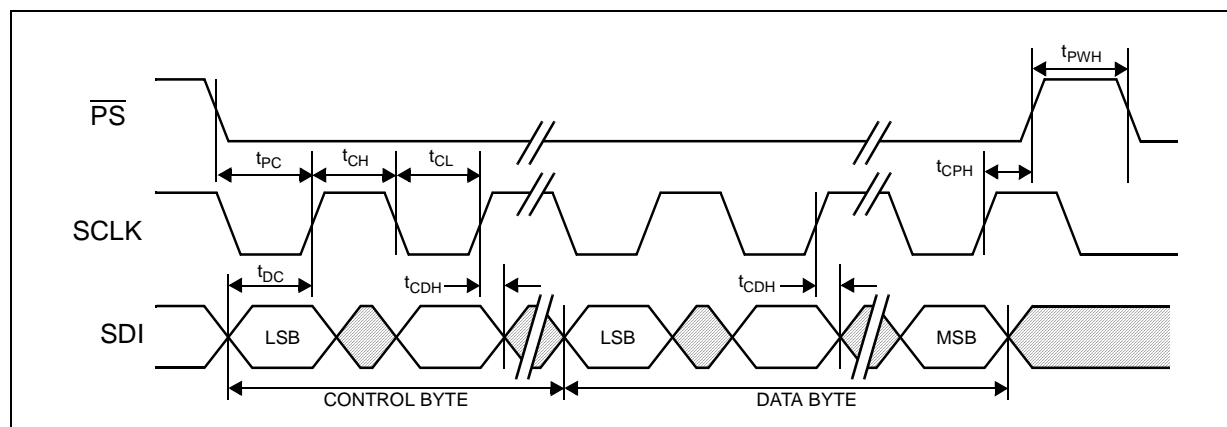

Figure 18. LXT332 Serial Data Output Timing Diagram

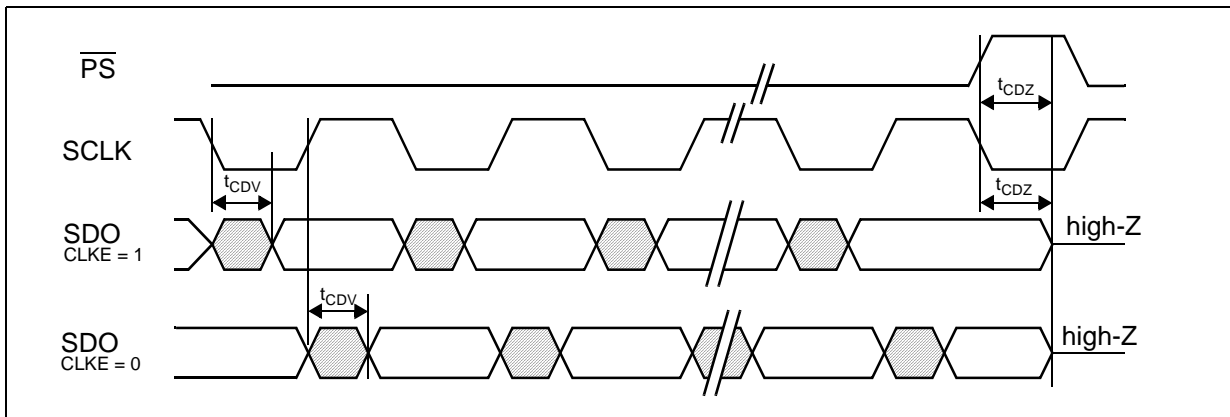

Figure 19. LXT332 Receive Clock Timing

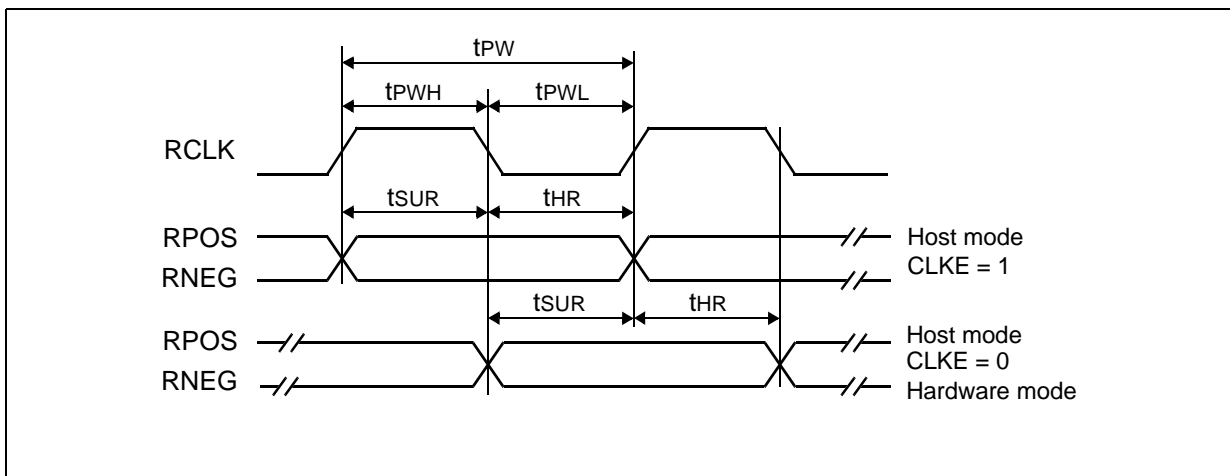

Figure 20. LXT332 Transmit Clock Timing

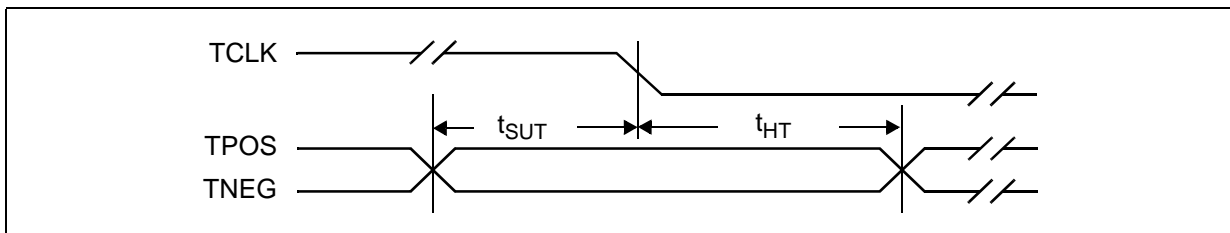

Table 16. LXT332 Receive Timing Characteristics (See Figure 19)

| Parameter | | Sym | Min | Typ ¹ | Max | Units | Test Conditions |
|---------------------------------------|-------|-------|-----|------------------|-----|-------|---|
| Receive clock period | DSX-1 | tPW | 583 | 648 | 713 | ns | Elastic store not in overflow or underflow. |
| | E1 | tPW | 439 | 488 | 537 | ns | |
| Receive clock duty cycle | | RCLKd | 40 | 50 | 60 | ns | |
| Receive clock pulse width High | DSX-1 | tPWH | 259 | 324 | 389 | ns | |
| | E1 | tPWH | 195 | 244 | 293 | ns | |
| Receive clock pulse width Low | DSX-1 | tPWL | 259 | 324 | 389 | ns | |
| | E1 | tPWL | 195 | 244 | 293 | ns | |
| RPOS / RNEG to RCLK rising setup time | DSX-1 | tsUR | 50 | 274 | – | ns | |
| | E1 | tsUR | 50 | 194 | – | ns | |
| RCLK rising to RPOS / RNEG hold time | DSX-1 | thR | 50 | 274 | – | ns | |
| | E1 | thR | 50 | 194 | – | ns | |

1. Typical figures are at 25 °C and are for design aid only; not guaranteed and not subject to production testing.

Table 17. LXT332 Master Clock and Transmit Timing Characteristics (See Figure 20)

| Parameter | | Sym | Min | Typ ¹ | Max | Units |
|------------------------------|-------|-------|-----|------------------|-----|-------|
| Master clock frequency | DSX-1 | MCLK | – | 1.544 | – | MHz |
| | E1 | MCLK | – | 2.048 | – | MHz |
| Master clock tolerance | | MCLKt | – | ±50 | – | ppm |
| Master clock duty cycle | | MCLKd | 40 | – | 60 | % |
| Transmit clock frequency | DSX-1 | TCLK | – | 1.544 | – | MHz |
| | E1 | TCLK | – | 2.048 | – | MHz |
| Transmit clock tolerance | | TCLKt | – | ±50 | – | ppm |
| Transmit clock duty cycle | | TCLKd | 10 | – | 90 | % |
| TPOS/TNEG to TCLK setup time | | tsUT | 50 | – | – | ns |
| TCLK to TPOS/TNEG Hold time | | thR | 50 | – | – | ns |

1. Typical figures are at 25 °C and are for design aid only; not guaranteed and not subject to production testing.

Figure 21. Typical Receiver Input Jitter Tolerance (Loop Mode)

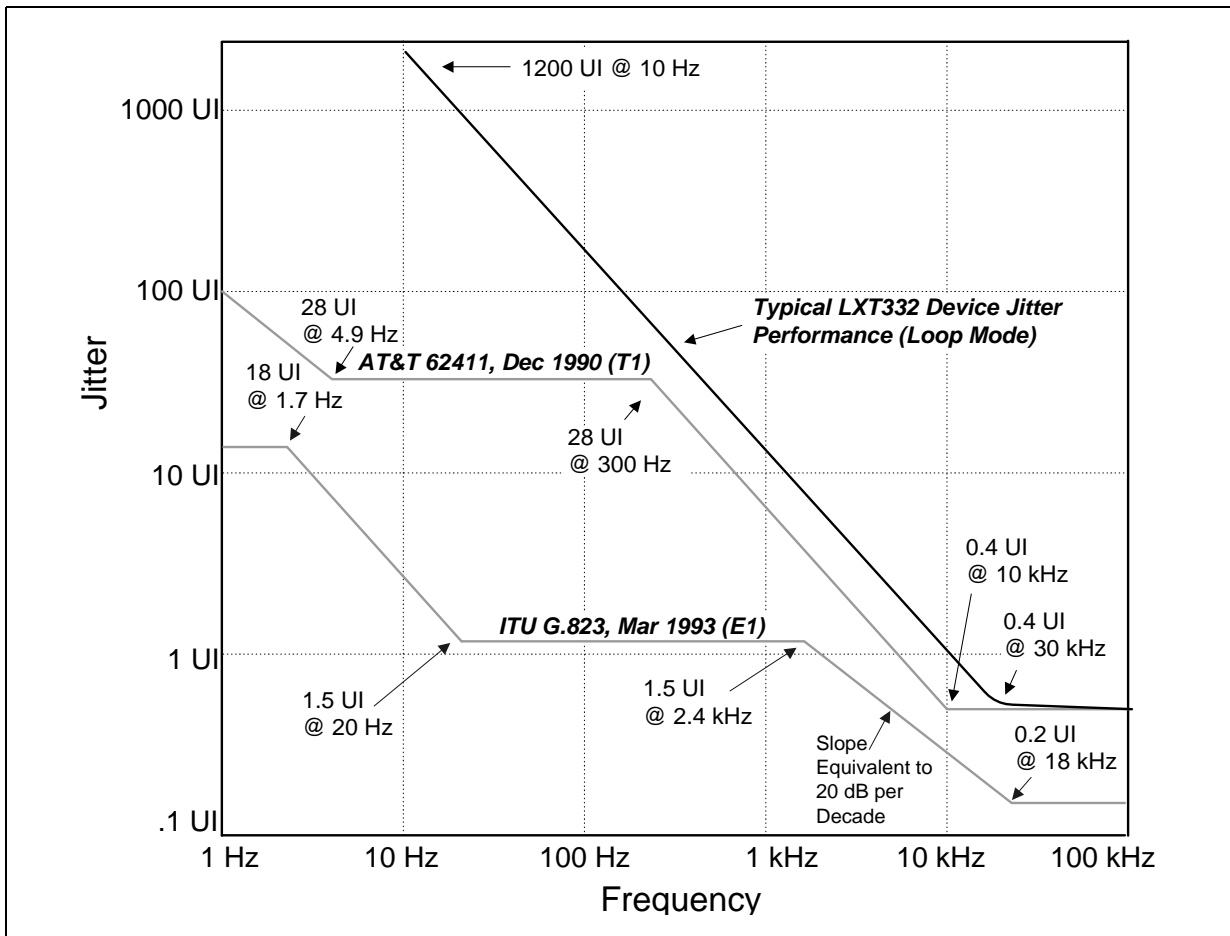
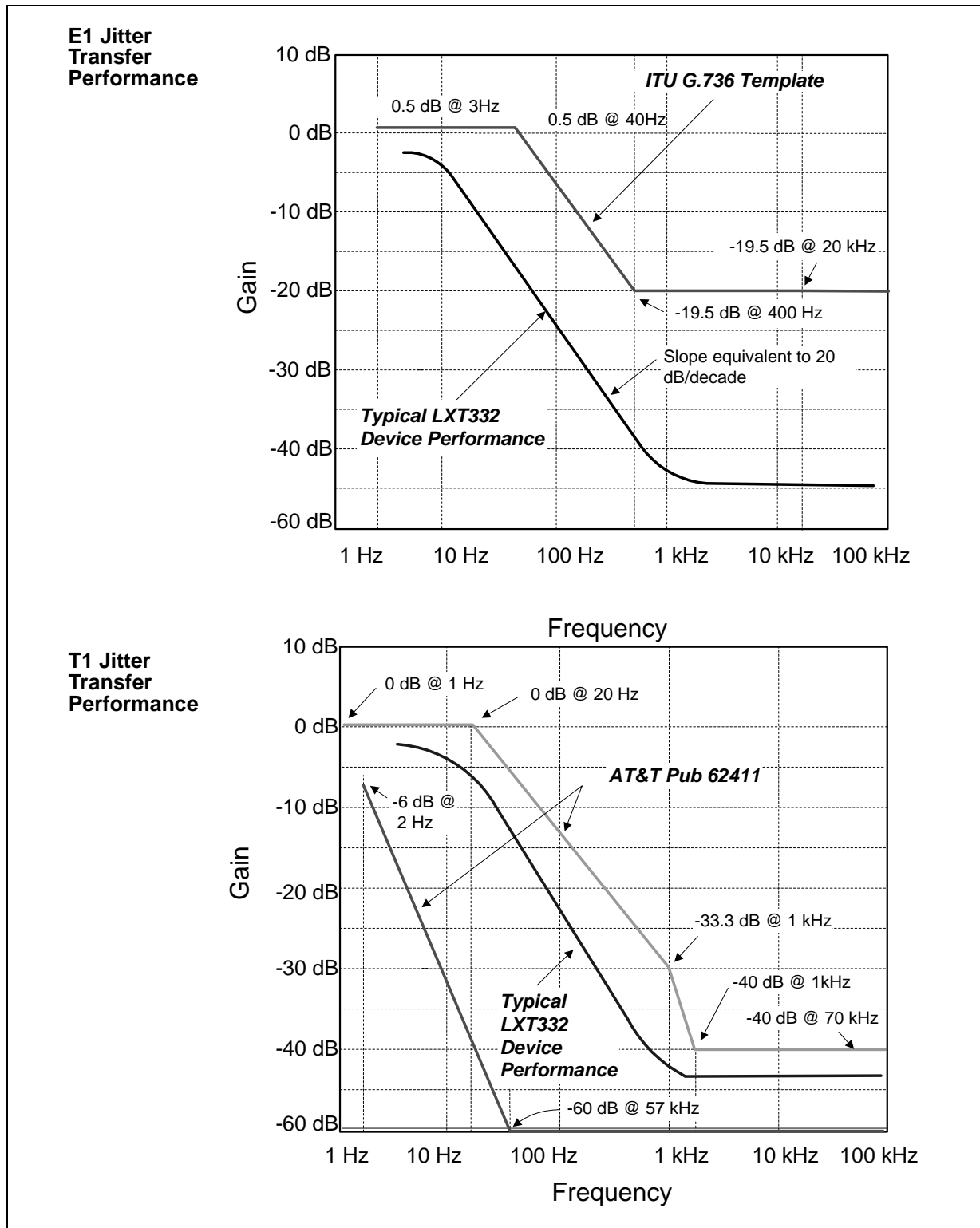

Figure 22. Typical Jitter Transfer Performance



6.0 Mechanical Specifications

Figure 23. LXT332 PLCC Package Specifications

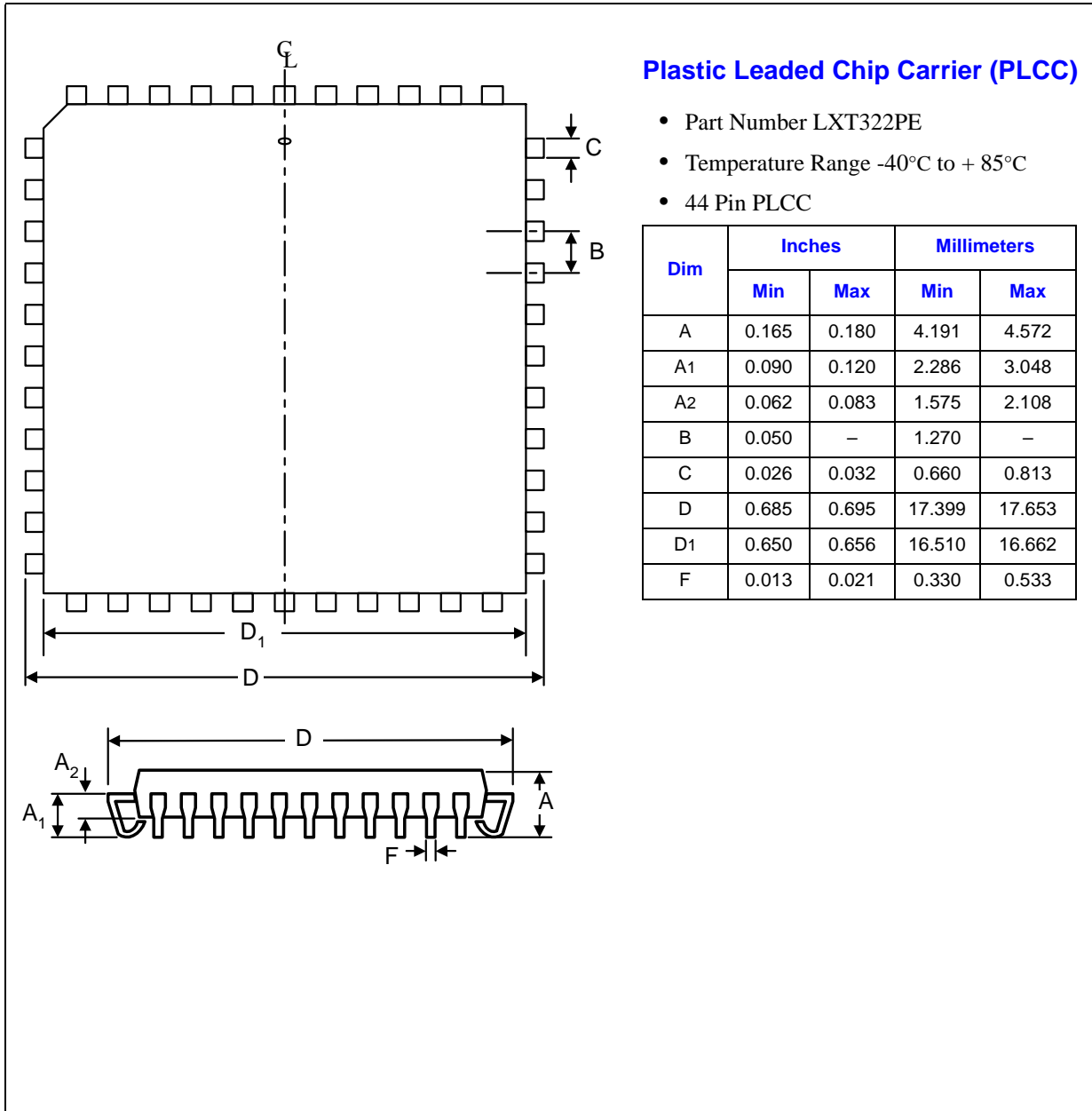

Figure 24. LXT332 QFP Package Specifications

